

**Board Report**

File #: 2015-1233, **File Type:** Policy**Agenda Number:** 50.

**SYSTEM SAFETY, SECURITY AND OPERATIONS COMMITTEE
OCTOBER 15, 2015****SUBJECT: TRANSIT SERVICE POLICY****ACTION: APPROVE THE 2016 TRANSIT SERVICE POLICY****RECOMMENDATION:**

SYSTEM SAFETY, SECURITY AND OPERATIONS COMMITTEE RECOMMENDED (3-0) approving the **2016 Transit Service Policy**.

ISSUE

The Metro Transit Service Policy (TSP) is the fundamental guide for the bus route design, scheduling, implementation and evaluation of Metro transit service. The TSP has been periodically revised over the past 20 years to meet existing and anticipated challenges. The 2016 Transit Service Policy was framed around the policy guidance obtained through the American Public Transportation Association (APTA) Peer Review Committee recommendations published in January 2015 along with advice of Metro's own Peer Review Committee that provided valuable insight into the policies presented here as well as advice on the implementation of a frequent service network.

DISCUSSION

The Transit Service Policy incorporates the following elements:

- Principles of Network Design, Market Analysis, Classification of Services, and Facilities Design Guidelines.
- Computation of load factors for bus and rail services, computation of maximum load for scheduling service, Route Performance Evaluation, Service Change Performance Evaluation, and the Metro-Muni Service Policy dealing with coordination of services and principles for possible assumption of Metro services by another provider.
- Implementation of the desired frequent service network, service priorities, restructuring plans.
- Service change process to encompass public review processes, Title VI requirements, and

coordination with our Union partners

Strategic Bus Network Plan, Peer Review Committee, and APTA Peer Review Process

Nationwide, transit ridership is either staying steady or is showing signs of a decline. Metro has taken on a multi-faceted campaign to reverse those trends in Los Angeles. In addition to annual evaluations of the services currently provided, Metro engaged APTA and representatives of its Local Service Councils to assist the agency in the refinement of the Strategic Bus Network Plan (SBNP). Their goal was to identify reasonable steps to improve the systems' performance, and to build a sustainable network of high quality, very frequent services. Metro's objectives are focused to allocate resources to maximize the benefits of service to transit riders while ensuring that service delivery is efficient and cost effective. Achieving this delicate balance requires establishing policy guidance and service standards that are designed to target levels of productivity, efficiency, quality, and equity.

The 2016 TSP document also provides for recommendations to improve the core Bus and Rapid service network, consideration of changes to the owl network, along with service guidelines developed for each type of service. The goal is to develop a high frequency network of sustainable services that provide a quality ride to our customers.

The principles enumerated below and supported by service standards outlined in Sections 2: Designing a Regional Transit Network, and 3: Service Design Guidelines are summarized as follows:

- Aggressively feed rail transit stations with convenient transfers to provide customers with faster and more frequent services.
- Identifying core bus services and increasing the peak frequencies to 15 minute headways. These services were reviewed and identified for enhancement by the Peer Review Committee.
- Changing bus load factors to better tailor service based on service frequency, vehicle size, and peak or off-peak operation.
- Culling out seldom used stops to improve the speed of the system.
- Re-invigorating the bus Rapid network and seeking opportunities to increase the number of rapid services.
- Right-sizing the owl network and providing convenient access to late night services in conjunction with rail operations.
- Working with Municipal and Local Return operators to improve service connections and where possible allow Metro to reinvest in its core services allowing local providers the opportunity to operate more service in their reserved service area.
- Seek expansion of point to point express services or Bus Rapid Transit (BRT) type services to extend the reach of the system and make connections between major centers of activity.

- Seek to innovate in the area of service provision and through provision of first mile-last mile connections.
- Seek to insure the involvement of Metro labor partners as the plan and program are developed and initiated through the planning and public review process.

The Transit Service Policy is a comprehensive guide for the development of public transportation services for the Los Angeles region. This update to the Policy recognizes funding constraints and seeks to establish principles for the use and distribution of scarce transit resources. Sections 5 and 6 deal with implementation of the proposed changes and direct the analysis and public information process and procedures that would be fulfilled to bring the recommended changes to fruition.

DETERMINATION OF SAFETY IMPACT

This Transit Service Policy and all recommendations identified will be implemented with full adherence to established safety policies and procedures.

FINANCIAL IMPACT

Implementation of any of the recommendations, elements, and principles (e.g. Directly Operated service adjustments based on boardings/service needs, right-sizing of duplicative Muni service, headway adjustments, Formula (fund) Allocation Procedure (FAP impact) will be analyzed and brought to the Board for approval.

NEXT STEPS

With the adoption of the 2016 Transit Service Policy, staff will initiate the Comprehensive Operations Analysis process which reviews the performance of each line in the system and based on that review will develop service change programs to achieve the goals of the plan. The goals include:

- Implement a network of high frequency bus lines
- Reallocate resources to better support core Rapid and Local Bus services
- Right size the owl network
- Provide opportunities to experiment with new or reinvigorated express, point to point services

Service changes drawn from this comprehensive service analysis will be taken through required public hearing processes starting with the Regional Service Councils.

ATTACHMENTS

Attachment A - 2016 Metro Transit Service Policies and Standards

Attachment B - Transit Service Policy Update Presentation

Prepared by: Jon Hillmer, Executive Director Service Development,

(213)922-6972
Gary Spivack, DEO Operations, (213)922-1241

Questions: Christopher Reyes, Transportation Planning Manager III, Operations (213)922-4808

Reviewed by: James T. Gallagher, Chief Operations Officer, (213)922-4424



Phillip A. Washington
Chief Executive Officer

TABLE OF CONTENTS

EXECUTIVE SUMMARY.....4

 BACKGROUND.....4

SECTION 1: INTRODUCTION, PURPOSE & BACKGROUND.....8

 1.1 Introduction.....8

 1.2 2015 Peer Review Committee (PRC) (Formerly known as the Blue Ribbon Committee BRC).....9

 1.3 Purpose.....11

 1.4 Background.....11

 1.5 APTA Peer Review Committee.....15

SECTION 2: DESIGNING A REGIONAL TRANSIT NETWORK.....17

 2.1 Key Principles of Network Design.....17

 2.2 Markets Served.....21

 2.3 Transit Service Classifications.....21

 2.4 Metro Transit Service Types.....22

 2.5 Alternative Service Delivery Options.....26

 2.6 Facilities.....26

SECTION 3: SERVICE DESIGN GUIDELINES.....29

 3.1 Metro Service Councils.....29

 3.2 Service Design.....32

 3.3 Customer Information & Amenities.....48

SECTION 4: SERVICE PERFORMANCE EVALUATION.....54

 4.1 Service Performance Indicators.....54

2016 Metro Transit Service Policies & Standards

4.2 Route Performance Index.....	59
4.3 Service Change Performance Evaluation.....	60
4.4 Service Policy Regarding Realignment of Metro and Municipal Bus Service.....	61
5.1 Changes to the Rapid Bus Network.....	66
5.2 Goals and Objectives.....	66
5.3 System and Service Evaluation.....	67
5.4 Develop Service Draft Restructuring Plan.....	68
SECTION 6: SERVICE CHANGE PROCESS.....	70
6.1 Title VI Equity Analysis.....	71
6.2 Public Outreach.....	74
6.3 Public Hearing Process.....	76
6.4 Implementing Minor Changes on an Interim Basis.....	77
SECTION 7: CONCLUSION.....	79
APPENDICES.....	80
APPENDIX A: 2015 PEER REVIEW COMMITTEE MEMBERS.....	81
APPENDIX B: METRO LINE IDENTIFICATION.....	82
General Standards.....	82
Printed Materials and Electronic Customer Information.....	82
Bus Stop Signage:.....	83
Vehicle Headsigns.....	83
Automatic Voice Announcements.....	83
Assigning Line Identifiers.....	83
APPENDIX C: METRO RAPID PROGRAM SERVICE WARRANTS.....	87
Corridor Alignment.....	87

2016 Metro Transit Service Policies & Standards

Stop Location.....	88
Transit Priority.....	88
Rapid Vehicle Fleet.....	89
Service Frequencies.....	89
Service Span.....	89
APPENDIX D: TYPICAL BUS STOP/ZONE DESIGN AND GUIDELINES.....	90
APPENDIX E: SCHOOL TRIPPER SERVICE CHANGE PROCEDURES.....	95
APPENDIX F: LOS ANGELES COUNTY LOCAL FIXED ROUTE TRANSIT OPERATORS.....	96
APPENDIX G: SERVICE CHANGE PROCESS.....	98

Metro Rapid Stop

EXECUTIVE SUMMARY

The Transportation Service Policy (TSP) document sets forth the policies, principles and requirements that will be used by Metro staff in the design or modification of the current service network in order to better serve our customers and make better use of available operating resources. Follow-on analyses will determine the actual service changes to be made in accordance with the requirements of the public review process. This document updates the 2012 version previously adopted by the Board.

BACKGROUND

On June 25, 2015, the Metro Board of Directors (Board) was given an update on the short- and long-term fiscal capacity of the agency.¹ The overall assessment of the agency's financial health is that both the capital and operating program is at risk given:

- The potential for economic downturn could trigger a recession event. Already signs are appearing that bids for capital projects are coming in higher than anticipated and operating costs are rising faster than the Consumer Price Index (CPI);
- Borrowing strategies which use the capacity of Propositions A and C are at risk because fares are not keeping pace with costs, and the demand for ACCESS Services transportation for the elderly and disabled are growing;
- New revenue sources are an important component for the agency's fiscal stability.

All told, for the period from FY2015 to FY2024, nearly \$1.8 billion in projects have been added to the Short Range Transportation Plan (SRTP), which, when combined with the need for specialized services for individuals that cannot use public transportation among other items, has created the potential for a \$1.0 billion operating shortfall. A fare increase would help keep the projected shortfall to the estimated \$1.0 billion mark. However, if fares remain flat, if ADA costs continue to rise, and/or the region experiences an economic downturn, the potential exists for the shortfall to more than double to \$2.1 billion within the same period. In short, the potential exists for Metro to be unable to support the very critical services needed by the residents and visitors of Los Angeles County.

In March 2015, the Board directed staff to look at ways to innovate and redesign the service system to better meet the changing needs of the Los Angeles region. The principles outlined in the TSP are intended to carry the agency forward over the next 5-10 year period and will support

¹ Fiscal Stability Overview and Funding Commitments Inventory (2014 SRTP Financial Update), Item 19.

2016 Metro Transit Service Policies & Standards

improvements to Metro's core services. The directives covered improvements to on-time service, improvements in service frequencies on core network bus services, and increased rail bus interface and coordination. These elements are incorporated herein.

Forecasts of Revenue Service Hours (RSH) for the agency reflect a flat and/or slightly declining number of hours allocated to the Local and Rapid Bus portions of the system. Bus Rapid Transit (BRT) Hours, conversely, are expected to grow with the projected conversion of a portion of Line 720 Rapid to BRT in FY16. Total Bus Revenue Service Hours (RSH) are fixed at 7,061,735 for FY2016 through FY2018, dipping slightly with the introduction of the Regional Connector and the Crenshaw Lines in FY20. Table 1.1 in Section 1 of this document displays the allocation of Bus RSH by year. Clearly, the supporting bus network will be constrained over the next 5-7 years.

Additions to existing services including new rail lines Expo Phase 2, Foothill Gold Line Extension, Regional Connector, and the Crenshaw Corridor should be considered as enhancements to the system. These new lines will expand the travel horizons for residents and visitors to Los Angeles County.

As a result of the recognized budgetary constraints, the Board of Directors engaged the American Public Transportation Association (APTA) to conduct a peer review of our service principles, fare structure, and mechanisms for acquiring and identifying new sources of revenue. Their recommendations were published in January 2015.

The APTA Peer Review panel made a number of recommendations to increase efficiency and productivity. The most significant of those recommendations were to increase the allowable number of standees on buses from 30% of a seated load to 40% of a seated load. The Committee also recommended that improvements in overall speed of the system were needed to increase the productivity of operations. Finally, the Committee recommended that resources be moved from less productive lines to higher productivity services to better accommodate passenger demand. A detailed listing of their recommendations is presented in Section 1.5 APTA Peer Review Committee.

In addition, Metro consulted with its own Peer Review Committee (PRC) to give input and make recommendations on:

1. Identification of gaps in the 15-minute frequent service network. Gap closure recommendations were prioritized by Service Planning staff into four categories (A-D). As discussed in Section 5, categories A and B will be incorporated into the work program and implemented in

phases. Later phases will incorporate recommended changes identified as priorities C and D.

2. Incorporation of the APTA Peer Review Committee findings into the TSP. The most significant was the change in the loading standard for buses based on seats by vehicle type and time of day; (see Section 4.2). The methodology for evaluating route performance, e.g. "Route Performance Index," was changed to evaluate all lines in sequence rather than within their specific service types. Hence, instead of measuring the performance of Express routes as a class of service, the Express routes were evaluated alongside all other routes. These evaluations are completed quarterly and will include an evaluation of the impacts of the service changes implemented.
3. Establishment of a policy direction for consideration of assumption of Metro line services by Municipal operators; see Section 4.3. Before a line can be assumed by another operator, Metro must cancel the service and observe all public notice and hearing guidelines.

The document also provides for recommendations to improve the core Bus and Rapid service network, consideration of changes to the owl network, along with service guidelines developed for each type of service. The goal is to develop a high frequency network of sustainable services that provide a quality ride to our customers.

The principles enumerated below and supported by service standards outlined in Sections 2 and 3 of the document are summarized as follows:

1. Aggressively feed rail transit stations with convenient transfers to provide customers with faster and more frequent services.
2. Identify core bus services and increase the peak frequencies to 15-minute headways. These services were reviewed and identified for enhancement by the PRC.
3. Change our bus load factors to better tailor service based on service frequency, vehicle size, and peak or off-peak operation. This includes a change to the method used to calculate the maximum load at the peak load point. Specifically, the approach is to use the mode in lieu of the average so that service calculations are based on the most likely expected load.
4. Cull out seldom used stops to improve the speed of the system.

2016 Metro Transit Service Policies & Standards

5. Re-invigorate the Bus Rapid network and seek opportunities to increase the number of Rapid services.
6. Right-size the owl network and provide convenient access to late night services in conjunction with Rail operations.
7. Work with Municipal and Local Return operators to improve service connections and where possible, allow Metro to reinvest in its core services allowing Local providers the opportunity to operate more service in their reserved service area.
8. Seek expansion of point-to-point Express services or BRT-type services to extend the reach of the system and make connections between major centers of activity.
9. Seek to innovate in the areas of service provision and provision of first mile-last mile connections.
10. Seek to insure the involvement of our labor partners as the plan and program are developed and initiated through the planning and public review process.

The TSP is a comprehensive guide for the development of public transportation services for the Los Angeles region. This update to the TSP recognizes funding constraints and seeks to establish principles for the use and distribution of scarce transit resources. Sections 5 and 6 deal with implementation of the proposed changes and direct the analysis and public information process and procedures that would be fulfilled to bring the recommended changes to fruition.



Metro Orange Line

SECTION 1: INTRODUCTION, PURPOSE & BACKGROUND

1.1 Introduction

Public transportation is a major force in redefining of communities both within Los Angeles County and within neighboring Counties. Transportation providers must be more nimble and capable to respond to the mobility needs of the next generation of Angelenos who increasingly use technology to arrange for their travel needs. Furthermore, service providers are no longer confined to just buses and trains, but must embrace and enhance the entire experience from the time a customer leaves their home to the time they reach their ultimate destination.

The Los Angeles County Metropolitan Transportation Authority (Metro) takes its role as a regional service provider broadly and is moving to enhance first mile-last mile transit options along with its program of rail expansion and development of a strategic bus network. Service quality, speed and frequency of service, as well as community connections are key elements of a strategic planning process that seeks to continually create a seamless and easy way to navigate the regional transportation systems.

Moreover, as stewards of the public dollars allocated to the organization, it is expected that the agency will make wise use of its resources. The provision of well-used, cost-efficient, reliable, and effective service is a prime mover for all transit agencies. “To attain this goal, public transit agencies must design their services around a clear and defined process as well as a process to monitor the results achieved and respond accordingly.”² This document puts forth those principles and standards.

Strategic Bus Network Plan, Peer Review Committee, and APTA Peer Review Process

Metro has taken on a multi-faceted campaign to increase ridership in Los Angeles. In addition to annual evaluations of services currently provided, Metro engaged APTA and representatives of its Local Service Councils to assist the agency in the refinement of the Strategic Bus Network Plan (SBNP)³ and take other reasonable steps to improve the current systems’

² “Best Practices in Transit Service Planning,” Project#BD549-38 Final Reports, Center for Urban Transportation Research, University of South Florida, March 2009.

³ The Strategic Bus Network Plan (SBNP) was developed through collaboration with the City of Los Angeles’s Planning Department and a consultant, TMD. The purpose of the plan is not only to provide a foundation for short term service adjustments, but to provide a basis for mid and long term coordination with other planning efforts (e.g. the City of LA’s Mobility Plan 2035), infrastructure investments (e.g. bus lanes, transit priorities, sub-regional transfer facilities), and funding opportunities (e.g. Cap and Trade, Sales Tax Measure). The plan has not yet gone to the Metro Board for adoption; however, Metro staff is in the process of developing recommended next steps and a path forward for the use and application of the

2016 Metro Transit Service Policies & Standards

performance and close service gaps towards building a sustainable network of high quality, very frequent services. Metro's goals and objectives are focused to allocate resources to maximize the benefits of service to transit riders while ensuring that service delivery is efficient and cost effective. Achieving this delicate balance requires establishing policy guidance and service standards that are designed to target levels of productivity, efficiency, quality, and equity.

Metro is committed to providing high quality transit service to all of its customers. These goals are reflected in Metro's Vision, Mission, and Core Business Goals, and carried forward as the foundation of this Transit Service Policy.

Vision

The agency is envisioned to be a world class operation that provides excellence in all of the services offered as well as excellence in supporting the continued growth and redevelopment of the region. Metro must insure that: our customers feel safe when riding, that they do so in clean equipment, service is reliable and on-time, and our staff is dedicated to providing service in a courteous manner.

Mission

Metro is responsible for the continuous improvement of an efficient and effective transportation system that is sustainable for Los Angeles County.

Core Business Goals

- Goal 1: Improve Bus & Rail Transit Services
- Goal 2: Provide Excellent Customer Service
- Goal 3: Deliver Metro's Bus & Rail Projects
- Goal 4: Ensure Civil Rights Compliance
- Goal 5: Deliver Metro's Highway & Freeway Projects
- Goal 6: Increase Emphasis on Safety & Security

In times of fewer resources, Metro's success to meet challenges related to serving the diverse needs of current and potential passengers, communities, and operators will be contingent on innovative thinking that stems from a solid base of sound planning principles. In addition, Metro seeks to work with other municipal operators and local return operators to provide support and connectivity throughout the Los Angeles region.

1.2 2015 Peer Review Committee (PRC) (Formerly known as the Blue Ribbon Committee BRC)

plan. Metro staff worked with the Service Councils to develop specific service recommendations based on the proposed Strategic Bus Network Plan, as recommended by an APTA Peer Review.

To help develop policy guidance for service development, Metro established a Blue Ribbon Committee (BRC) in November 2009 represented by key stakeholders who serve as operators in the region as well as beneficiaries of transit service. In 2015, a new committee was formed with much of the same membership. This committee was designated a Peer Review Committee (PRC) and met five times to review elements of the TSP and make recommendations relative to the service network.

The PRC recommended a service concept conveyed as a set of policy statements that provides a blueprint to build a better transit system for greater regional mobility while consuming fewer resources. The service concept also defines the roles of Metro Bus, Rail, and municipal operations, identifies and prioritizes essential service quality attributes, and recommends policy guidance on service coordination, bus-rail integration, and reduction of duplicative services. The key principles of the service concept set policy direction for Service Priorities, Service Design, Service Quality Attributes, and Governance. A list of the 2015 PRC participating members is provided in Appendix A.

Summary Position Statement

Increased regional coordination and integration of service, and improved reliability are essential to having a seamless system that is convenient, simple to use, and of high quality – and provides maximum benefit in light of scarce resources.

- **Service Priorities:** Service should be focused first in high-density areas and be scaled to fit the overall density and passenger demand in the service area.
- **Service Design:** The network should be coordinated and designed to be simple and user-friendly to increase trip-making by existing riders and attract new riders.
- **Service Attributes:** The system should provide high quality transit service to better serve existing riders and attract new riders. Service quality priorities include:
 - Reliability
 - Fast travel options
 - Real-time information
 - Clean and safe transit vehicles, stops, and transit facilities (e.g. Transit Centers, Park & Ride, Rail Stations, etc.)
- **Governance:** Metro should serve as a facilitator to coordinate services among operators in the region.

Ultimately, the policy guidance is reflected in the Transit Service Policy as a set of regional network and service design guidelines, performance criteria

2016 Metro Transit Service Policies & Standards

and standards. In addition, this document outlines the service change process that provides the quantitative tools to evaluate the system, identifies opportunities for service improvements, and ensures the regional transit system is adjusted accordingly to achieve the goals and objectives of the service concept.

1.3 Purpose

Metro's Transit Service Policy (TSP) establishes the following: (1) a formal process for evaluating existing services; (2) a methodology and process for developing and implementing service adjustments; and (3) service design guidelines to ensure that the transit system is developed consistent with policy guidance approved by the Metro Board of Directors.

The TSP was originally adopted in 1986 and is reviewed on an annual basis. When required, the TSP is updated to better reflect agency goals and objectives, major initiatives, and changes in local, state, and federal regulations and funding.

This document updates the 2012 TSP formerly adopted in July 2012. The policy is organized into seven sections:

- Introduction, Purpose & Background
- Designing a Regional Transit Network
- Service Design Guidelines
- Service Performance Evaluation
- Implementing the Plan
- Service Change Process
- Conclusion

1.4 Background

Metro is the 3rd largest transit provider in the United States. Metro's service area is over 1,400 square miles and is divided into five distinct service areas overseen by their respective Metro Service Councils; their role and responsibilities are described in Section 3.1. Metro supports transit operation throughout Los Angeles County with an annual budget of approximately \$5.668 billion. In 2016, Metro will spend \$1,050.4 billion on its bus operations and \$399.2 million on its rail operations. The remainder of the budget goes toward fare subsidies, funding a number of other local return operators, and funding Access Services, the principal Americans with Disabilities Act (ADA) paratransit provider in the County. Table 1.1 displays the major budget categories and expenditures for 2016.

Table 1.1 *Summary of FY16 Expenditures by Program*

Expense Category	FY16 Budget	Comments
-------------------------	--------------------	-----------------

2016 Metro Transit Service Policies & Standards

Metro Bus & Rail Operations	\$1,472.4 billion	Includes Bus, Rail, operations & regional activities
Metro Capital Expenses	\$2,131.3 billion	Includes operating capital and new construction
Subsidy Funding Programs	\$1,373.1 billion	Metro distributes subsidies to Municipal Operators, Local Return Operators, Metrolink, and Access Services ⁴
Congestion Management & Highways	\$ 93.1 million	Includes Freeway Service Patrol, Express Lanes, Call Box, Intelligent Transp., and Rideshare services
General Planning & Programs	\$ 169.8 million	Includes Planning programs and studies, Legal, audit, treasurer, Transit Court and other, and Property Management/Union Station and Development
Debt Service	\$ 328.7 million	
Total FY 2016 Expenditures	\$5,568.4 billion	

Source: LACMTA FY16 Adopted Budget for July 1, 2015 - June 30, 2016, Summary of Expenditures by Program, Page 34.

Metro's transit system consists of light rail, heavy rail, and bus operations. Metro's bus operations consist of both directly operated services and contract operated services. Metro operates the largest share of all bus services provided in the region. However, municipal and Local Return operators provide additional public bus and paratransit services in areas of the region where Metro provides limited service or no service at all.

Metro currently operates 169 bus routes, of which 18 routes are contracted out, and 6 rail lines. On weekdays, Metro currently operates 1,957 peak buses and 190 peak heavy and light rail cars. On any given weekday, Metro experiences approximately 1.1 million bus boardings and 350,000 rail boardings. Metro serves over 15,000 bus stops, including station stops on the Orange Line and Silver Line. Metro operates six rail lines (2 heavy and 4 light rail lines) serving a total of 73 stations across approximately 84 route miles. Metro Rail operates in heavily congested travel corridors and provides connections to many key multi-modal transportation hubs.

Measure R and the 30/10 Initiative

Metro will continue to expand its transit network across the region under Measure R and the 30/10 Policy Initiative. In November 2008, Los Angeles County voters approved Measure R, a half-cent sales tax. The measure is expected to generate \$35 billion for countywide transportation projects over 30 years. In April 2010, Metro's Board of Directors adopted the 30/10

⁴ It is important to note that Metro Operations is a recipient of the distribution of subsidies from Metro as regional service provider. Metro does not directly subsidize other operators.

2016 Metro Transit Service Policies & Standards

Initiative to use revenue from Measure R as collateral for long-term bonds, grants, and anticipated federal loans that will allow Metro to reduce the time needed to build 12 major transit projects from 30 years to 10 years. Part of the funds generated through Measure R will be used to expand Metro Rail projects throughout the region. Five of the twelve projects listed or under consideration are currently under construction and projected to begin operations within the next several years; one project has been completed:

- Gold Line Foothill Extension to Azusa (FY 2016)
- Exposition Line - Phase II to Santa Monica (FY 2016)
- Crenshaw/LAX Light Rail (FY 2020; subject to change with addition of Airport Metro Connector)
- Regional Connector Transit Corridor Project (FY 2021)
- Purple Line Extension to Westwood (Extension to La Cienega FY 2023; Extension to Century City FY 26; Extension to Westwood FY 35)
- Gold Line Eastside Extension from East Los Angeles - Phase II (Under Study)
- Rail Extension to South Bay (Under Study)
- Orange Line Canoga Extension (completed)
- Airport Metro Connector
- East San Fernando Valley Transit Corridor
- West Santa Ana Branch
- Sepulveda Pass

Figure 1.1 illustrates Metro's projected rail network by 2022 along with its Metro Liner services (Orange Line and Silver Line).

2016 Metro Rail Service Policies & Standards



Figure 1.1 Metro Rail Projected Concept Map

1.5 APTA Peer Review Committee

In 2014, Metro contracted with APTA to perform a peer review of the restructured fare policies, proposals to increase the efficiency and productivity of service operations, and to provide guidance on alternative sources of revenues to support operations. The panel met in Los Angeles during the week of January 26-30, 2015. As a result of their review, the panel made the following recommendations to increase efficiency and productivity:

1. Adjust the bus load standard from 1.3 to 1.4 and ultimately consider going to an area-based standard;
2. Consider implementation of a bus stop consolidation plan to improve speed of operations;
3. Initiate a system-wide program to improve in service on time performance;
4. Seek to coordinate operations with other local service providers in the region;
5. Adopt and implement a policy to guide the redeployment of resources from chronically underperforming routes or route segments to higher performing locations and times;
6. Develop a service design to minimize duplication and encourage transfers among modes;
7. Provide frequent service on a more sparsely configured network;
8. Realign services to establish and maintain a core network of frequent services, and;
9. Encourage the use of the system at off-peak times and days.

These recommendations, along with the recommendations of the PRC, have been incorporated into the service policies and standards outlined in this document.

2015 PRC Recommendations

The 2015 PRC reviewed the proposed 15-minute frequent service bus map along with major change proposals that are incorporated into this update to the TSP. The PRC completed a number of tasks and made recommendations as follows:

1. Identified and recommended development of services to address gap closures in the 15-minute frequent service network. Gap closure recommendations were prioritized by Service Planning staff into 4 categories (A-D). As discussed in Section 5, categories A and B will be incorporated into the work program and implemented in phases.
2. Recommended incorporation of the APTA Peer Review Committee findings into the TSP. The most significant was the change in the

2016 Metro Transit Service Policies & Standards

loading standard for buses based on seats by vehicle type and time of day; see Section 4.2.

3. Established a policy direction for consideration of assumption Metro line services by Municipal operators; see Section 4.3.

The PRC by virtue of its composition of members of the Regional Service Councils and other operators in the region had a significant impact on the generation of the 2016 TSP.

SECTION 2: DESIGNING A REGIONAL TRANSIT NETWORK

Transit network design must take into account both the needs of the passengers and transit operators, as well as the practical ability to provide the service. From the passenger's perspective, the transit network should provide convenient service when and where they need to go, operate on time and safely, with good customer service and information. From a system-wide transit operations perspective, the transit network must be manageable, operable, and sustainable – all within the constraints of a fixed operating budget.

2.1 Key Principles of Network Design

At times, competing service interests result in unproductive use of scarce transit resources. As such, the PRC was charged with identifying and prioritizing the needs of the customer and the operator. Based on recommendations from the PRC, critical factors to consider in network design should be reliability, network simplicity, speed, and safety, followed by vehicle cleanliness and timely, relevant, accurate customer information.

The following key principles are critical in building an efficient and effective transit network based on the PRC policy guidance:

A. Develop a Network of Services Rather than a Collection of Individual Routes

Individual routes do not need to serve all market needs. Rather, routes should be designed to serve a specific purpose within the network. Combined, the network should provide service between all major destinations and densely populated areas throughout the day. The transit network includes integration of other public transportation services within Los Angeles County, as well as with other modes, such as bikes, carpool/vanpool, car share, and private shuttles that provide first and last mile transportation to better access the transit network.

B. Integrate Services to be “Seamless to the User”

Transfer Penalties Should Be Minimized

In developing an integrated network, it is essential that the system is seamless to use from a customer's perspective. The need to create a simple and convenient system that minimizes transfer penalties is critical. An integrated regional network should emphasize high frequency service, timed transfers on less frequent services, and shared stops for ease of transfers.

Trip information, way-finding, and an integrated fare structure also are important elements of a customer-focused transit network.

Services Must Be Better Coordinated

Given the significant growth in municipal and local return operators as well as Metro Rail, improved coordination between all operators and modes is vital to establishing an integrated regional transit network. Metro serves as a regional coordinator of transit services. In addition, Metro operates within a hierarchy of services, in which Metrolink provides the region's commuter rail to serve high volume, longer distance trips. Metro Rail and Metro Liner (Orange Line and Silver Line) serve as the backbone of the urban transit network, which is augmented by Local, Limited stop, and Rapid bus service on key corridors operated by Metro along with municipal operators. LADOT and local return operators complement the system with community and shuttle buses that serve specific neighborhood needs.

Metro meets quarterly with various municipal and local return operators impacted by Metro's service changes. (Section 5.2 discusses the service change process in greater detail.)

Minimize Duplication and Increase Shared Stops

From both the patron and operator point of view, operation of overlapping services may be costly, confusing and unproductive. Through better service coordination, duplication between Metro and municipal bus services as well as between bus and rail service can be reduced. This concept will result in an easier and simpler to use transit network. Opportunities to share stops also will help reduce confusion.

Customer Trip Information Must be Timely and Readily Available

Timely, relevant, accurate, and readily available trip information is necessary to minimize rider confusion about using transit service. Patrons should always be kept informed about the status of their trip. Real-time information is useful for reassuring passengers when the next transit vehicle will arrive or how long the expected delay time is if there has been a service disruption. It should provide them with options such as whether to continue their wait time for the next transit vehicle, consider alternate routes, or take another mode of transit to complete their trip.

C. Keep the Service Simple and Easy to Use

An easy-to-use-and-understand transit system relies on simple network and route design. Consolidating services on the same or parallel corridors within a quarter-mile to a half-mile distance provides an opportunity to simplify the network for ease of use and reduce unused capacity. This concept requires better coordination of schedules and transfer points, and will result in an

easier-to-use and more convenient system while reducing wait time and overall travel time. These enhancements to service quality are expected to help increase ridership and revenue at no additional cost.

Furthermore, consistent headways that are predictable for patrons also help to reduce uncertainty about next bus arrival times. Consistent headways should be a priority for lines that operate headways of less than 15 minutes.

D. Ensure High Quality Services

Establishing a world-class transportation system requires identifying and prioritizing service quality attributes that support an effective and sustainable operation. The following are critical service quality attributes of highest priority to consider when designing service:

Reliability

When it comes to key service quality attributes, reliability should be given highest priority. Reliability can be impacted by poor schedule adherence, vehicle breakdowns, and missed trips. Controlling service reliability requires a coordinated effort between establishing reasonable running times and schedules, maintenance and management of vehicles, and operator availability and performance. Service levels are scheduled to meet passenger levels. Early, late or missed trips result in capacity issues and can eventually lead to pass-ups. Therefore, it is essential that service is on time and reliable to avoid the misperception that service levels are inadequate to meet demand.

Passengers generally maintain a level of confidence that transit service should depart a stop or station and arrive at a destination as stated on the timetable. However, instances of poor reliability can cause passengers to arrive late to work or school, miss appointments or critical transit connections, and result in an overall lack of confidence in the system. Furthermore, poor reliability creates unnecessary travel delays and greater concerns about safety and comfort due to longer waits at stops and stations.

For high frequency service with headways of every 15 minutes or better, schedules should be written to allow operators to be on time without excessive running time that can slow the service substantially and result in additional operating costs. Passengers who miss a trip on high frequency services can be comforted knowing that another bus or train will be available within a reasonable wait time, minimizing the consequences of reliability.

Reliability becomes even more critical for low frequency service with headways greater than 15 minutes and as wide as 60 minutes. Missing trips

on low frequency service increases the consequences to the passenger given the significant travel delays and wait times. Therefore, special attention should be made to ensure low frequency services are designed and operated to the greatest reliability and efficiency.

Achieve Higher Network Speeds

Increasing the speed of transit service improves the competitiveness of transit as compared to other modes, such as automobiles. Faster service also requires fewer resources to operate, thus reducing operating costs. Several factors cause a reduction of speed along a route, including turns, particularly left turns, an increased number of stops, traffic-congested corridors, and long dwell times at stops and stations.

While the advantages of increasing bus system speed include attracting new riders and reducing operating cost, there are disadvantages in reduced access to the transit network due to the streamlining of routes and limiting the number of stops. Therefore, adjustments to a route that result in slower speeds are warranted when the ridership benefits outweigh the negative impacts to speed.

Passenger Capacity

Passenger capacity, or the amount of seats and standing room onboard a vehicle, is an important consideration when designing transit service. The utilization of vehicle capacity should be maximized to make the most use of resources. However, capacity should not exceed a threshold that deters ridership due to uncomfortably crowded conditions or excessive stop and station dwell times caused by blocked passageways on board.

Capacity thresholds are expressed as a load factor indicating the ratio of available capacity to seats. This indicator is used to determine how many trips must be scheduled for each direction of travel during specified time periods.

Other considerations that may influence design capacity include the duration that passengers must stand based on passenger turnover along the line and operating conditions, such as on freeway routes in which standees should be minimized.

Safe Routing and Stops

Perceptions of safety and security as well as actual conditions enter into a customer's mode choice decisions. Safety includes the potential for being involved in a crash, slips and falls, and other elements such as aggressive passengers or poor passenger conduct. Security covers both real and customer perception of potential incidents of crime that may contribute to a passenger's unease, even if the actual risk is minimal or non-existent.

Measures must be taken to alleviate a passenger's unease both at stops and onboard transit vehicles. Whenever possible, stops should be located at well-lit areas with ample sidewalk space for ADA compliance and queuing for buses. Other measures to enhance security at stops and on board transit vehicles include police officers in uniform and plainclothes who ride transit, two-way radios, silent alarms for emergency communications, and surveillance cameras at stops and on board transit vehicles. Metro's bus operators form the core of the agency's response to any situation that may arise while driving in service. Operators have the ability to silently alert Bus Operations Control (BOC) and /or local law enforcement. They are the initial incident responder and must remain in contact with BOC.

Cleanliness and Courtesy

Clean and well-maintained transit stops, stations, and vehicles improve the general public's perception of Metro and their desire to take transit as a viable mode of travel that is comfortable, convenient, and of high quality. Many elements make transit more comfortable for passengers, including climate-controlled vehicles, seat comfort, courteous operators, and ride comfort.

2.2 Markets Served

Given the current financial climate, service should be placed when and where the maximum benefit can be provided to the general public. In addition, productive service lowers the net cost per hour, resulting in more service per dollar.

In general, service should be focused on corridors and within areas where high density population, employment, and activity centers exist. These corridors and areas usually generate high levels of transit riders to justify frequent service (15-minute or better headways) that provides convenient access to key origins and destinations. Corridors and areas with dense ridership should be served throughout the day and week. The emphasis on service should be during peak periods, base day, weekends, and late night, in priority order.

While service should focus on when and where significant demand exists, there is still a need to provide basic lifeline service in areas and times of day with low demand. Therefore, a basic lifeline network should be provided on critical corridors during the owl period and to connect low density areas to the transit network.

2.3 Transit Service Classifications

2016 Metro Transit Service Policies & Standards

Metro classifies its bus services into three categories to provide the framework for evaluation and planning of the various components of the transit network.

Core Regional Network

Core regional service consists of Metro Liner (Metro Orange Line, Metro Silver Line), Metro Rapid, Metro Local (for bus lines averaging 9,000 or more boardings per weekday), and Metro Rail. Together these lines form the basic network in the region and serve the region's major activity centers and market areas. Other regionally significant lines may be under consideration for service improvements as part of the Strategic Network and are discussed in Section 5.

Significant Corridor Bus Services

Significant corridor bus services provide regional service along major arterials throughout the service area and carry 4,000 to 9,000 riders per day. Metro operates 14 Local lines, one Express line, and 10 Rapid lines that meet this threshold. These lines cover long distances, serving both intra- and inter-community trips, and have an average trip length of approximately 5.2 miles.

Inter-Community and Community Service

Inter-Community and Community Service supplements the core service, provides primary coverage in outlying areas, feeds the fixed-route system, and provides community circulation focusing on local travel. This includes the remainder of the system including Local and Express lines.

2.4 Metro Transit Service Types

Metro operates six types of bus service (Table 2.1) and two types of rail service to better match the transit mode with specific passenger demand and needs. (See Appendix B for Metro's Bus Line Identification, Route Numbering, and Color Conventions.)

Metro Rail

Metro Rail is high capacity rapid transit service using rail technology. It operates along a dedicated right-of-way, serves full scale transit stations, and is powered by electricity. The rail system serves as a backbone of public transportation in the greater Los Angeles region, linking many key multi-modal transportation centers and destinations together.

Service operates in high-demand travel corridors and is offered in two forms - heavy rail and light rail. Metro's heavy rail is the subway system served by the Red and Purple Lines. Metro's four light rail lines - Blue, Green, Gold and Expo - are powered by overhead wires, generally use shorter trains, and

operate at slower speeds than heavy rail. Unlike heavy rail, light rail lines run along a right-of-way ranging from complete grade separation to at-grade in mixed flow traffic. Rail routes are designated with route numbers between 800 and 899.

Metro Liner and BRT Services

Metro Liner service is expedited BRT service that operates on either an exclusive right-of-way, major arterial, or HOV/HOT lanes. Metro operates two Liner routes: the Orange Line which operates on its own exclusive right-of-way, and the Silver Line which operates along the HOV lanes of two freeways as well as surface streets through downtown. Metro Liner service is numbered between 900 and 910. As a form of BRT, Metro incorporates a series of design features to reduce delays, increase reliability and improve passenger comfort:

- **Dedicated Bus Lanes:** This right of way provides fewer traffic conflicts and obstructions and reduces delays and travel time.
- **High-Capacity Vehicles:** State-of-the-art high-capacity vehicles are used to meet high demand and provide greater passenger comfort.
- **Transit-Signal Priority:** An operational strategy that facilitates the movements of in-service transit vehicles through signalized intersections to improve transit performance by extending the green phase or shortening the red phase of traffic signals.
- **Bus Stations and Shelters:** Stations and shelters provide customers with enhanced comfort and safety.
- **Streetscape:** Streetscape and other design features such as landscaping, pedestrian count-down signals, bicycle racks, and well-designed crosswalks make it easier for pedestrians and bicyclists to access the stations.
- **Improved Fare Collection:** For faster service and convenience, major stations have ticket vending machines (TVMs) which allow passengers to prepay.
- **Park & Ride Facilities:** Should be provided in close proximity to major stops and stations. Adjacent development and joint use parking also is encouraged.
- **Advanced Transportation Management Systems:** ATMS provide an array of technologies to improve service reliability and passenger travel.

Metro is currently looking at adding bus lanes in order to further improve travel times on major corridors. A peak period bus lane on Wilshire Blvd. benefiting Rapid Line 720⁵ opened in FY15. An additional section of Wilshire Blvd. (between Federal and Centinela) is scheduled to open in the fall of

⁵Local Line 20 also benefits from use of the peak bus lanes.

2016 Metro Transit Service Policies & Standards

2015 to further increase the speed of the Rapid service. In addition to two rail alternatives, there are two BRT alternatives being evaluated in the environmental document for the Van Nuys Boulevard Corridor in the east San Fernando Valley. If BRT is chosen as the preferred alternative, the project could provide a seamless connection to the Metro Orange Line.

Metro Rapid

Metro Rapid is a form of BRT that operates in mixed-flow traffic on heavily traveled corridors. Time reductions are achieved through the use of a number of key BRT attributes such as fewer bus stops and transit signal priority. Metro Rapid services use specially branded buses and enhanced bus stops that include special shelters and information kiosks. Metro Rapid Lines are designated with route numbers between 700 and 799.

Service warrants guide the design, monitoring and development of the Metro Rapid program. The warrants are specific targets or objectives that are linked to each of the program's key attributes. These warrants are presented in Appendix B. Current Metro Rapid Lines in operation are evaluated as outlined in Section 4.0.

Metro Express

Metro Express is used for longer distance trips with fewer stops and typically becomes more localized near the ends of the routes. Metro Express service usually operates from a collector area, such as a Park & Ride location, directly to a specific destination or in a particular corridor with stops en-route at major transfer points or activity centers. In addition, a major portion of its routing generally operates on freeways either in mixed flow traffic, *HOV* and/or *HOT* lanes, or dedicated bus lanes. This service type charges a premium fare and Express services are designated with route numbers between 400 and 599. Express services serving downtown Los Angeles are given a 400 route number, while those that do not go downtown are given a 500 route number.

Metro Limited Stop

Metro Limited is an accelerated bus service with limited stops. Metro Limited operates in corridors with high transit demand and provides higher-speed services by limiting stops to key transfer points and major activity centers. It is augmented by Local bus service. Metro Limited bus service does not include signal priority or unique branding. Limited stop routes are designated with route numbers between 300 and 399.

Metro Local

Metro Local services operate on city streets and provide service to all stops along a route. Metro Local provides the bulk of Metro's transit service and

2016 Metro Transit Service Policies & Standards

ridership. Local routes are designated with route numbers between 1 and 299.

Metro Shuttle

Shuttle routes operate primarily on secondary streets and serve short-distance trips. These services specialize in local community circulation and connect residential neighborhoods with local trunk-line transit services, including rail. Typically these services carry less than 2,000 passengers a day. These bus routes are designated with route numbers between 600 and 699. Table 2.1 highlights Metro's bus service types and features.

Table 2.1 *Metro Bus Service Types and Features*

FEATURES	BUS SERVICE TYPES				
	Local/ Limited	Express	Shuttle	Rapid	Metro Liner
Right of Way	Major Arterials	Major Arterials and Fwys.	Local Streets	Major Arterials	Dedicated Right-of-Way
Minimum Average Stop Spacing	0.25 mile / 0.60 mile	1.25 miles	0.25 mile	0.80 mile	1.25 miles
Target Travel Market	Inter-Community	Inter-Community Regional	Neighborhood	Inter-Community	Inter-Community
Vehicle Type	40/60-foot bus	40-foot bus	40-foot bus or smaller	40/45/60-foot buses	45/60-foot buses
Color Coded Buses	California Poppy	California Poppy	California Poppy	Rapid Red	Silver
Communities Served	Multiple	Multiple	1 - 2	Multiple	Multiple
Signal Priority	No	No	No	Yes	Yes
Fare Collection	On Board	On Board	On Board	On Board	On Board /Pre Pay ⁶
Passenger Amenities	Benches and Shelters	Shelters and Stations	Benches and Shelters	Shelters and Stations	Shelters and Stations ⁷
Real-time Passenger Info	No	No	No	Yes	Yes

⁶Only the Metro Orange Line has off-board fare collection at this point. The Metro Silver Line currently only accepts fares through the fare box on board.

⁷Metro Silver Line Service has a section of on-street boarding and alighting in downtown Los Angeles.

2016 Metro Transit Service Policies & Standards

Route Number Designations	1-399	400-599	600-699	700-799	900-910
---------------------------	-------	---------	---------	---------	---------

It is recognized that strict adherence to a stop spacing standard may not be possible in all cases due to street geography or facility design. For example, on the Silver Line the distance between stations on the freeways is greater than the desired minimum.

2.5 Alternative Service Delivery Options

Alternative service delivery options are services not directly operated by Metro, including Local Return Operators, van service, taxicabs, flexible destination operations, contracted services, and scrip programs. These transportation options may be viable alternatives to marginally performing fixed-route options and can complement traditional transit service. Metro is also considering working with ride-sourcing service providers, e.g. Lyft and Uber, to potentially provide additional first-mile and last-mile service options. In addition, Access Services provides mandatory ADA complimentary paratransit services to individuals whose disabilities prevent them from using fixed route transit services.

2.6 Facilities

Transit services are supported by facilities including bus stops, transit centers and stations. These locations are often the first and last points of contact with the passenger. The PRC considered these facilities to be an essential component of transit infrastructure that direct passengers to existing transit services, provide a safe and comfortable environment in which to wait for service, and facilitate safe and efficient transfers between services. Given the importance of transit facilities, it is vital that transit routes and schedules are developed with consideration for the quality, appropriateness, and availability of facilities.

Bus stops are places where passengers safely wait, board and alight along a route in service. They consist of route line number, destination and service qualification signage, curb markings or parking restriction signage and may include passenger amenities such as shelters, benches, telephones, trash receptacles, lighting and information displays installed by the appropriate municipality. Most bus stops are located along the curb of a street, while others are at offsite facilities such as transit centers or rail stations that may be owned and maintained by the local municipality or by Metro.

2016 Metro Transit Service Policies & Standards

Transit stations are stops along a fixed guideway with features, such as loading platforms, ticket vending machines for fare pre-payment, shelters, benches, lighting, information displays, trash receptacles, bike racks and lockers, and emergency call boxes. Many of them also are connected to Park & Rides and passenger pick-up/drop off areas.

Transit centers are high volume transfer points for multiple transit services and layover spaces for end-of-line bus storage and turn around. Features include passenger loading and alighting areas, benches, shelters, lighting, information displays, bicycle racks and lockers, trash receptacles, and bus layover bays.

On-street bus layover zones are designated stopover points for either a bus at or near the end of the line. They may or may not allow for passenger boarding and alighting. Bus terminals are major offsite layover areas for multiple bus lines and may or may not allow for passenger boarding and alighting.



El Monte Station

Locating bus facilities (other than on-street stops) in heavily congested or urbanized areas increases the burden on the transit operator to find layover

spaces for buses and operator restrooms. At times, the extension of a line to a specific terminal may prove uneconomical and at the very least add costs to an already budget constrained operation. The PRC recommended that Metro Operations continue to evaluate routes and layovers to reduce costs and improve the efficiency of the operation. In particular, with the expansion of the rail network, the Service Development Department, as a key internal stakeholder in the environmental planning process, reviews and comments early on in the alternatives to be analyzed, as well as developing mitigation measures, to ensure adequate layover space is addressed on future projects. Cost and minimization of passenger disruptions are significant concerns when locating facilities for bus operations. Capital costs of new support facilities is an important determinant; but more significant is the added operating cost that may be incurred due to the lack of adequate facilities. The PRC strongly recommended that as new rail stations and transit facilities are designed, that Metro require the calculation of the additional operating cost that will be incurred as a result of inadequate bus facility design.

SECTION 3: SERVICE DESIGN GUIDELINES

The PRC's policy guidance states that Metro's transit network should be well integrated, coordinated, and designed to be simple and user-friendly to increase trip making. To ensure an integrated and not duplicative system, Metro Rail, Metro Rapid, and other exclusive guideway services (e.g. Metro Orange Line and Metro Silver Line) should serve as the backbone of the transit system, fed and complemented by a regional bus network of key travel corridors that provide high-frequency service for easy transfers. Less-frequent localized services should augment the regional network to provide geographic coverage.

For network simplicity and to create a more intuitive system, closely-spaced services should be consolidated into fewer, more frequent services at a half-mile to one mile route spacing. For ease of use, transfers should be as seamless as possible by providing high frequency routes on the regional network, timed transfers for less frequent services, and consolidated bus stops at the same intersection.

Finally, since the regional transit network consists of more than 40 fixed route operators and many more local return transit services, coordination of services and alignment of schedules should be a high priority. Coordinated planning and scheduling between Metro, Muni, Local Return, and Metrolink operations are essential towards achieving this service integration.

3.1 Metro Service Councils

Metro decentralized its bus operations in 2002, creating five localized service areas each overseen by a Governance Council (Figure 3.1). In 2010, Metro restructured and re-established a centralized bus controlled operation to include the service planning and scheduling function, while maintaining the role and responsibility of the Councils to help coordinate service changes. Metro restructured the roles and responsibilities of the Governance Councils, now referred to as Metro Service Councils. These community-based councils offer:

- **Greater Community Involvement:** Regionalized outreach gives residents more opportunities for direct input into service issues in their communities.
- **Improved Service:** Local service evaluation to better understand passenger needs and recommend the appropriate response.
- **Sub-Regional Perspective:** Advise and approve the planning and implementation of service changes within their area; call and conduct public hearings; evaluate Metro bus programs related to their service

2016 Metro Transit Service Policies & Standards

area; review and approve proposed service changes; and, make policy recommendations to the Metro Board.

2016 Metro Transit Service Policies & Standards

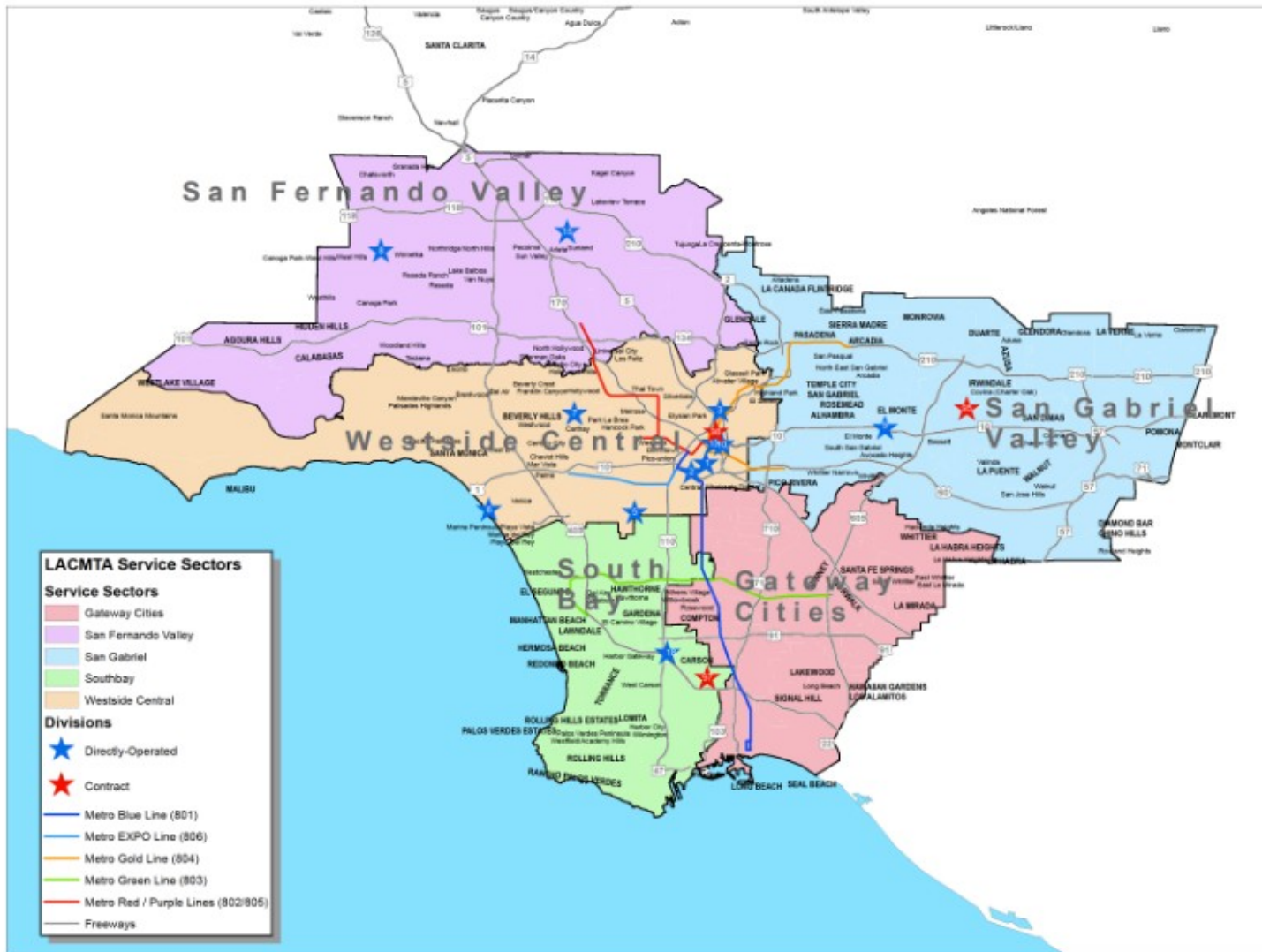

Figure 3.1 Metro Service Council Areas

3.2 Service Design

A. Service Type Determination

Metro operates a Local, Limited, and Rapid bus grid network system overlaid by services, such as Rail and Express bus services, and supported by shuttle bus feeder/community services. Determining the most appropriate transit service in a corridor depends on a number of factors, including level of demand, resource availability, site or corridor characteristics, environmental considerations, and community acceptance. Table 3.1 below shows desirable characteristics considered during the initial review of proposals to upgrade existing operations. The demand thresholds include the combined ridership levels for all services operating in the corridor.

Table 3.1 *Service Type Determination*⁸

Service Type	Corridor	Optimal Characteristics
Heavy Rail (Subway)	Operate 100% within an exclusive right of way.	- 2,500 boardings per route mile or more than 50,000 boardings per day. - Ability to construct a fully grade-separated facility.
Light Rail	Operate in mixed flow traffic or an exclusive right of way.	- 1,000 boardings per route mile or more than 25,000 boardings per day. - Ability to construct a guideway within or adjacent to the corridor.
Express Routes	Operate in mixed flow traffic in along either an HOV or HOT Lane and may operate a segment of their route on local streets.	300 or more boardings during peak-hour and in peak direction of travel.
BRT and Rapid	Operated using 40', 45' or 60' buses. - Metro Orange Line (BRT) operates on a fixed guideway. - Metro Rapid Lines operate in exclusive bus lanes or mixed flow traffic on local streets with signal priority.	- 300 or more boardings during peak-hour and in peak direction of travel. - Daily average of more than 500 boardings per route mile or more than 10,000 total daily boardings. - Ability to implement operating speed improvements in the corridor.
Local,	Operate in mixed flow traffic	- 80 or more passengers during

⁸Capacity limits adapted from TCRP, Research Results Digest, November 1999—Number 35, Highlight of Large Transit Capacity and Quality of Service Manual, Figure 1 Achievable Capacity (Peak direction passengers/hour)

Limited, and Shuttle Routes	on local streets by 32', 40', 45', or 60' buses.	peak-hour and in a single direction of travel. - Total daily boardings greater than 2,000.
------------------------------------	--	---

B. Physical Routing Guidelines

Metro primarily operates three types of buses: a standard 40-foot bus, a 45-foot bus, and a 60-foot “articulated” bus. To ensure that buses can adequately navigate route alignments and serve bus stops, Metro established the following standards:

- **Transit Centers /Bus Terminals**
 - Layover zones should be designed to accommodate various sizes of buses (40-foot, 45-foot, and 60-foot).
 - Re-striping of layover zones should be implemented as-needed based on the needs and bus sizes scheduled.
 - Routes should be scheduled in such a way that the amount of layover space can be accommodated. Layover zones should be placed as close as possible to the route terminal. Where not accommodated by the design, the added operating cost to serve the location will be computed and made part of the decision-making process for bus/rail interface.

- **Minimum turning radius clearance** required for each type size bus movement
 - 50 feet for 40-foot buses (Figure 3.2)
 - 44 feet for 60-foot articulated buses (Figure 3.3)
 - 47.5 feet for 45-foot buses (Figure 3.4)

2016 Metro Transit Service Policies & Standards

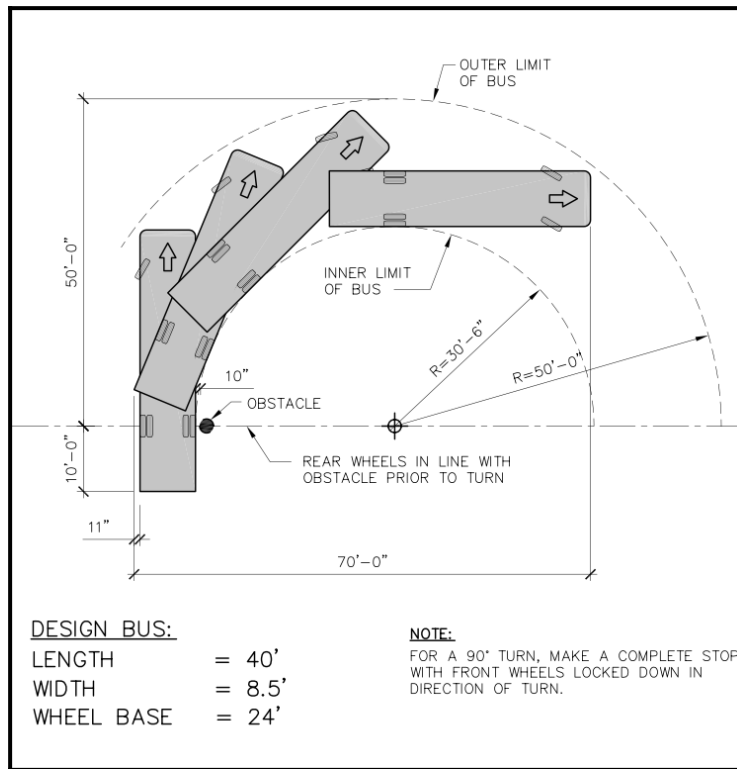

Figure 3.2 40-foot bus turning radius

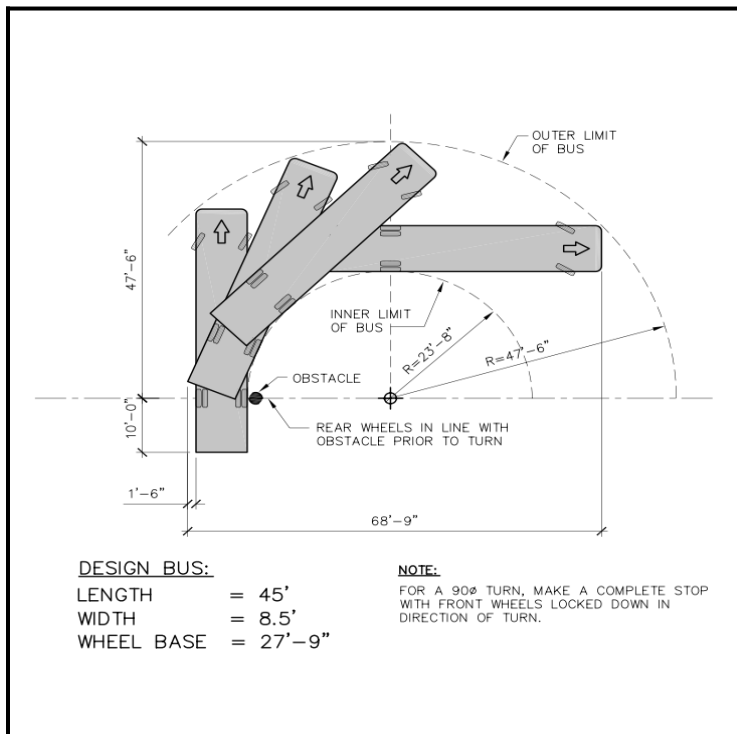

Figure 3.3 45-foot bus turning radius

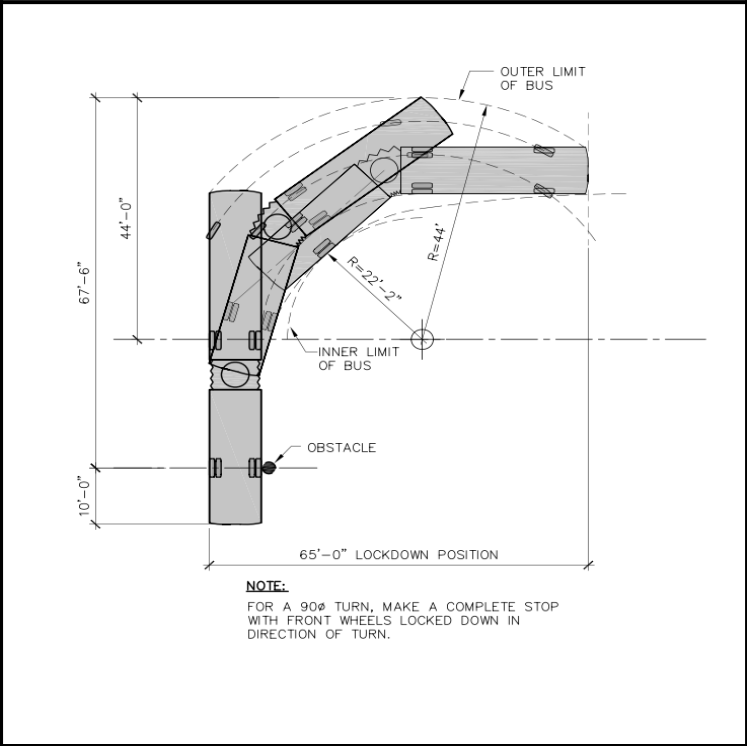

Figure 3.4 Articulated 60-foot bus turning radius

- **Desired street lane widths** for bus operations should be 12 feet or more.
- **Optimal Bus Stop Curb Lengths and Zone**
40-foot buses should at minimum:
 - Far-side – 90 feet
 - Near-side – 100 feet
 - Mid-block – 150 feetFor two 40-foot buses servicing a stop simultaneously, add 50 feet. Additional bus stop curb length may be needed for 45-foot buses.

60-foot bus should at a minimum:
 - Far-side and mid-block – 120 feet
 - Near-side – 170 feetFor two 60-foot buses servicing a stop simultaneously, add 70 feet.
- **Bus Layover Zone** general space requirements based on frequency between scheduled trips:
 - One Space – 15 minutes
 - Two Spaces – 12 minutes
 - Four spaces – 6 minutes

Appendix D provides a number of renderings illustrating a typical bus stop/zone design and offers guideline for near-side, far-side, and mid-block locations. TCRP Report 19 “Guidelines for the Location and Design of Bus Stops” (1996) provides a more detailed discussion.

C. Bus & Rail Service Guidelines

- **Corridor/Route Duplication** refer to a collection of parallel routes serving several common destinations. If the route spacing is such that patrons could walk to one or the other within the same amount of time and distance, then relatively speaking these routes can be considered duplicative services.
- **Bus Route Duplication** occurs when two or more bus routes operate on the same alignment by one or more carriers in a transit corridor.
- **Rail Line Duplication** occurs when an Express or Rapid bus service operate a significant segment parallel to a rail line. This standard does not apply to Local bus service. While service duplication should be minimized, exceptions apply such as Metro Rapid bus corridors that support an underlying local route, on approaches to business districts, major terminals, and transit centers, or if serving key destinations along a corridor from several directions.

- **Headway/Frequency** refers to the interval of time, expressed in minutes, between consecutive trips. Headways are based on policy and demand. Frequency is driven by the amount of time separation between scheduled trips, otherwise known as the headway, and refers to how often the arrival of a trip occurs in a given period. For example, if the headway of a line is 10 minutes, its frequency is six trips every hour. Service frequencies should be set to provide sufficient capacity to adequately meet the demand and ensure that a reasonable and attractive level of service is provided throughout the day. Section 4.1 discusses Metro’s Headway/Frequency standard and policy.
- **Limited-Stop Bus Service** makes significantly fewer stops than Local service. The key design objective is to operate at a minimum of 10% faster than Local service. Limited service will be considered in corridors where the demand requires 10-minute headways or less on the Local line prior to implementation of a Limited-stop service.
- **Bus & Rail Passenger Load Ratio** is the average ratio of passengers on-board to seats available commonly measured over a one-hour period. A passenger load ratio standard indicates what proper headway should be scheduled. Section 4.1 discusses Metro’s Load Ratio standard and policy.
- **Network Route Spacing** refers to the average distance between two or more parallel bus and/or rail lines. It is generally accepted that patrons are willing to walk up to one quarter mile to a bus stop. In general, bus routes operating parallel to each other in an urban area should be spaced a half-mile apart from one another and bus routes operating parallel to rail should be spaced a half-mile apart on either side of a rail route. Bus routes operating parallel in a suburban area should be spaced no more than one mile apart from each other, and bus routes operating in low density or underdeveloped areas should be operated where needed in such a way that it is cost-effective. When possible, alternate delivery methods should be considered.
- **Bus & Rail Route Alignment** should be direct for network simplicity and to maximize average speed and minimize travel time. In general there should be no more than two branches per trunk-line route. Rail alignment is decided during the design phase of a fixed guideway/right-of-way and is beyond the scope of this TSP.
- **Bus Route Deviation** also referred to as “out of direction movement,” is when a route is realigned to operate in close proximity of a new activity center such as a rail station or transit center. Route

2016 Metro Transit Service Policies & Standards

deviation should only be considered if the diversion time in one direction is 5 minutes or less, and there is a net travel time benefit for riders who are connecting to other services.

- **Bus Route Length** should be as short as possible to reduce a vehicle’s exposure to events that may delay service (e.g. accidents, road construction, or poor weather conditions) and to maintain scheduled travel times to maximize on-time performance.
- **Bus & Rail Span of Service** refers to the hours that service is available on a given day and defines the minimum period of time that service should operate at any point in the system (Table 3.2). A key factor in determining the span of service on individual lines is based upon system connectivity. This provides customers with the confidence that direct and connecting service will be provided.

Some of the criteria used to determine the span of service on a bus route include:

- Existing ridership and productivity levels
- Span of service on connecting and alternative services with expanded service
- Resource availability
- Hours of operation of major job sites or activity centers along the alignment

Table 3.2 *Standard Span of Service by Service Type*

Service Type	Weekday	Weekends
Heavy Rail	4:30am - 1:30am	4:30am - 2:30am
Light Rail	4:00am - 2:00am	4:00am - 2:00am
Metro Liner	4:00am - 2:00am	4:00am - 2:00pm
Metro Express	Varies by line No Typical Span	Varies by line No Typical Span
Metro Rapid	5:00am - 9:00pm	6:00am - 8:00pm
Metro Local	5:00am - 11:00pm	6:00am - 9:00pm
Metro Rail Feeder/Shuttle	5:00am - 9:00pm	6:00am - 9:00pm

- **Transfers** occur when passengers change from one transit unit to another (bus or rail) at a common stop location such as an intersection, station, or transit center. Metro’s goal is that transfers should be seamless and minimize wait times as much as possible. Metro accomplishes this through timed transfers and positive transfers.
 - **Timed Transfers** are when wait times are built into the schedule of a route to provide convenient connections between two routes for

passengers who wish to transfer at a common stop location. In these instances it is preferable that wait times be built into the schedule of a low frequency route with headways greater than 20 minutes and owl routes that operate every 30 minutes or greater.

- **Positive Transfers** are when one route is scheduled to arrive 2-5 minutes before or after another route at a common stop location to enhance connections and reduce wait times for passengers who wish to transfer from line to another, such as connections between bus and rail.

Metro will work with other municipal transit operators to better coordinate services and schedules to minimize transfer impacts.

D. Bus Stop/Station Stop Location

Bus stops and station stops allow for boarding and alighting of passengers and their location should balance safe and convenient rider access with pedestrian safety. Their locations should support efficient transfer movements, minimizing walking distances, unnecessary crosswalk movements, and preferably be located at a signalized crosswalk to prevent potential jaywalking violations. Bus stops are generally located within a short walk from medical facilities, schools, major retail malls, office buildings, multi-unit apartments and other major activity centers. These stops provide access to the transit system for uses that generally attract a large number of transit riders. Hospitals and schools have high priority when considering new bus stop locations and/or when relocating existing bus stops.

Bus/Rail station locations are determined during the design phase of a fixed guideway/right-of-way. There is a set of criteria associated with station location, but this is beyond the scope of this transit service policy. Generally, stations are located at major transfer points with bus or rail and provide access to major activity centers. No standard type of stop can be recommended for all locations, as each intersection has its own unique characteristics. An inventory of land uses within a quarter-mile corridor of the road under consideration should be taken, particularly uses that serve as major trip producers and attractors. The proper location of a transit stop requires on-site investigation of the stop(s) under consideration and must be concurred by the municipality in which the stop is located in.

Whether a bus stop should be located at the *near-side* of the intersection, the *far-side* of the intersection or at "*mid-block*" has been a source of debate. In general, far-side stops are preferable; however, other types of stops may be justified in certain situations. There are advantages and disadvantages to each location (Table 3.3). TCRP Report 19 "Guidelines for

2016 Metro Transit Service Policies & Standards

the Location and Design of Bus Stops” (1996) provides a more detailed discussion.

For Rapid Bus stop locations, the current warrants recommend that the stops be placed far-side in order to take advantage of the Transit Priority System for signals. The PRC recommended further that where possible, Rapid and Local stops should be placed on the same side of the street to avoid passengers having to choose which line to take and then having to attempt to cross the street to gain access to the first trip to arrive.

Metro Rapid Bus

2016 Metro Transit Service Policies & Standards

Table 3.3 *Comparative Analysis of Bus Stop Locations*

Stop Type	Advantages	Disadvantages
Near-Side	<ul style="list-style-type: none"> ▪ Minimizes interference when traffic is heavy on the far side of the intersection ▪ Passengers access buses closest to crosswalk ▪ Intersection available to assist in pulling away from curb ▪ Buses can service passengers while stopped at a red light ▪ Provides driver with opportunity to look for oncoming traffic including other buses with potential passengers 	<ul style="list-style-type: none"> ▪ Conflicts with right turning vehicles are increased ▪ Stopped buses may obscure curbside traffic control devices and crossing pedestrians ▪ Sight distance is obscured for crossing vehicles stopped to the right of the bus. ▪ The through lane may be blocked during peak periods by queuing buses ▪ Increases sight distance problems for crossing pedestrians
Far-Side	<ul style="list-style-type: none"> ▪ Minimizes conflicts between right turning vehicles ▪ Provides additional right turn capacity by making curb lane available for traffic ▪ Minimizes sight distance problems on approaches to intersection ▪ Encourages pedestrians to cross behind the bus ▪ Requires shorter deceleration distances for buses ▪ Gaps in traffic flow are created for buses re-entering the flow of traffic at signalized intersections 	<ul style="list-style-type: none"> ▪ Intersections may be blocked during peak periods by queuing buses ▪ Sight distance may be obscured for crossing vehicles ▪ Increases sight distance problems for crossing pedestrians ▪ May increase number of rear-end accidents since drivers do not expect buses to stop again after stopping at a red light
Mid-Block	<ul style="list-style-type: none"> ▪ Minimizes sight distance problems for vehicles and pedestrians ▪ Passenger waiting areas experience less pedestrian congestion 	<ul style="list-style-type: none"> ▪ Requires additional distance for no-parking restrictions ▪ Encourages patrons to cross street at mid-block (jaywalking) ▪ Increases walking distance for patrons crossing at intersections and for transferring passengers

Source: FTA webpage (http://www.fta.dot.gov/12351_4361.html)

There are instances when two or more bus routes operate along the same corridor. In these cases, it is desirable that stops be consolidated to avoid unnecessary crosswalk movements and minimize confusion as to which stop riders should wait to catch their bus. However, stops cannot be consolidated in the following instances:

- Unsafe right turn movements

- Objections from businesses adjacent to stops
- Loading zones (business & passenger)
- Jurisdiction refusal to allow extending current stop zone
- Lack of available space

Bus Stop/Station Accessibility: All stops and stations should be fully accessible in accordance with the Americans with Disabilities Act. For example, there should be no obstructions preventing the boarding and alighting of patrons who use a wheelchair or other assistive mobility devices. In addition, pathways to and from a stop or station should be unobstructed. If obstructions do exist, every effort must be made to resolve with the respective municipalities. In the case of bus stops, they can either be moved to a new location on a permanent basis or temporary basis depending on situations, such as during construction.

E. Bus Stop/Station Spacing

Stop/Station spacing refers to the average distance between consecutive stops/stations along an entire bus/rail route. Stop/Station spacing are established based on the goals and guidelines each service type is designed to achieve as discussed below and summarized in Table 3.4.

The standard is expressed as the maximum average stop/station spacing in miles by type of service and is not to be exceeded by at least 90% of all routes operated. The following establishes Metro's maximum average stop/station spacing by mode:

- **Heavy/Light Rail Line** station spacing is even greater than bus stop/station spacing to achieve the highest speed among the various modes and service type. Rail station location is determined during the design phase. Ideally the average rail station spacing should be no greater than 1.50 miles.
- **BRT and Express Bus Routes** achieve the highest bus speeds through even greater stop spacing than Rapid and Limited routes. To ensure these services provide access to major activity centers and transfer points, the average stop/station spacing should be no greater than 1.25 miles. (There may be exceptions to this due to geography or existing facility design. See Stop Spacing discussion under Section 2.4).
- **Rapid and Limited Bus Routes** operate on the most heavily traveled corridors. Both services achieve their speed advantage largely through serving fewer stops than Local bus operation. However, to ensure

these services provide access to a significant portion of patrons within the corridor, the average stop spacing for Rapid routes should be no greater than 0.80 mile and no greater than 0.60 for Limited routes.

- **Local Bus and Shuttle Routes** primarily operate on city streets and secondary streets respectively. Both route types are designed to provide service closer to a passenger’s destination and reduce walking times. Therefore, both Local and Shuttle routes average stop spacing should be no greater than 0.25 mile for passenger convenience.

Decisions regarding bus stop spacing and location call for careful analysis of passenger service requirements, the safety of passengers, operators, equipment, the service type provided, and the interaction of stopped buses with general traffic flow. Achieving a balance of convenience to both the transit passenger and the auto user is a prime objective. In addition, bus stop spacing should be related to ridership density. Stops should be closer together in major commercial districts and farther apart in outlying areas.

Table 3.4 *Maximum Avg. Stop/Station Spacing*

Service Type	Stop/ Station
Heavy Rail	1.50
Light Rail	1.50
BRT	1.25
Rapid	0.80
Express	1.25
Limited	0.60
Local	0.25
Shuttle	0.25

F. Bus Lanes

A bus lane is an exclusive lane used by transit on urban streets along a roadway through widening or dedication of one or more existing general traffic or parking lanes for transit use. These lanes can be designated for transit use during peak periods only or all day. These lanes typically allow use by general traffic for right turn movements, bicycles, parking, and local access to and from driveways. Bus lanes are most effective in those areas where there are very high bus volumes or passenger volumes and where operational efficiencies can be achieved. Bus lanes should be a minimum of 17 feet wide.

G. High Capacity Bus

Metro operates two high-capacity vehicle types: 45-foot buses with 46 seats and articulated 60-foot buses with 57 seats. Ideally, high-capacity vehicles should primarily be operated on high-volume trunk service routes such as Line 720 (Wilshire Blvd.) and Lines 204 and 754 (Vermont Blvd.), which currently operate 60-foot articulated buses.

One advantage to their deployment is the opportunity to reduce vehicle requirements and service hours; however, their deployment should not increase service intervals to the point where riders notice degradation in service quality. For this reason, bus lines with a peak headway of five minutes or less (frequency of 12 trips or more an hour) are ideal candidates for this type of vehicle. In evaluating services for higher capacity vehicles, other factors must be considered including facility compatibility, street design, and potential impacts to services where schedules have been interlined.

H. Bus/Rail Integration

As the Metro Rail system expands, adjustments are made to the bus system to improve access to rail stations, take advantage of new transfer facilities, and reduce bus and rail service duplication. The following guidelines provide direction to routing and scheduling changes that will be necessary as the Metro Rail system is expanded:

Discontinuation of Parallel Limited and Express Service

Competing Limited and Express services that parallel the rail corridor will be discontinued when duplication exists.

Bus Route Deviation

Bus routes that run parallel to a rail line may be diverted to a station when:

- Walk time from the nearest station is greater than 3 minutes;
- Diversion time in one direction is 5 minutes or less; and
- Net travel time benefit for connecting passengers exceeds increased travel for through travel.

Intersecting bus lines or ones that travel in a perpendicular direction to a rail line will be diverted to serve the closest rail station when:

- Diversion time in one direction is 5 minutes or less
- Net travel time benefit for connections and through travel

Extend Terminating Lines

Bus routes that end within one mile of a rail station will be extended to terminate at the station. Routes that terminate at distances greater than one mile may be extended if the rerouting will create a valuable link to the rail

system or will result in a reduction in travel time for a significant number of riders.

New Bus Routes

New rail feeder service will be considered as part of the service change process if a need is demonstrated and if funding is available.

Scheduling Bus Interface

During peak travel periods, bus arrival and departure times should be governed by the rail arrival and departure times when predominant movement is from bus to rail.

During off-peak times, bus routes with frequencies of 20 minutes or greater ending at a rail station should be scheduled to arrive 2-5 minutes before the rail departure time.

When the predominant movement is from rail to bus, terminal buses should be scheduled to depart 2-5 minutes after the scheduled rail arrival time.

I. School Trippers

School trippers are extra service operated to protect against overcrowding on bus routes serving schools. Metro's policy on school trippers is based on FTA regulations (49 CFR Part 605). These regulations are directed at protecting the private sector against unfair competition and ensuring that FTA funding is focused on providing services that meet the needs of the "general public."

School tripper service may be operated if it meets the following criteria:

- There is sufficient demand to warrant the operation of a tripper;
- There are sufficient resources to operate a tripper;
- The school tripper will not result in a significant increase in travel time for regular customers; and
- The school tripper is operated as part of the regularly scheduled public transportation service.

School tripper service must meet the following requirements:

- All school trippers must fully comply with established policies and procedures;
- All regularly scheduled school trippers must be published on public timetables;

- All locations where trippers board or alight passengers, including the bus stops at deviated routes, must be marked with Metro signage including the bus line numbers servicing the stop;
- School tripper changes must be provided to the general public by a service change notice or on the Metro website at www.metro.net; and
- Requests for new school trippers or modifications to existing school trippers will be considered when a notice is given at least two weeks in advance providing ample time to complete an appropriate analysis of the request and to allow appropriate notification of changes.

School Tripper Service Change Procedures are listed in Appendix E.

J. Special Event Service

Special event services are bus routes designed to take passengers to a specific venue and are not part of the regularly scheduled operation. Metro will provide service under contract to other entities only if the provision of these services do not interfere with Metro's ability to meet its regularly scheduled service obligations and fits within the scope of the agency's regular operation in terms of route structure, fares and span of service. Special event services will be provided on a full cost recovery basis and in conformance with the agency's charter bus policy.

K. Charter Bus Policy

Charter service is the use of buses, vans or facilities (rail system) to provide a group of persons under a single contract, at a fixed charge, with the exclusive use of the vehicle or service to travel together under an itinerary either specified in advance or modified after having left the place of origin. Generally, for service not to be considered charter, it must meet the following tests:

- Be available to the general public;
- Operate within the system's normal scope (existing routings, fit within normal hours of operation and established fare structure);
- Provide a published timetable; and
- Customers must pay their own fare.

As a grantee of Federal funds, Metro is prohibited from using its federally-funded equipment and facilities to provide charter service except on an incidental basis and when one or more of the applicable exceptions below apply:

- Charter service shall be incidental to the mass transportation service and shall be provided only during times of the day when vehicles are not needed for regularly scheduled service.

- Charter service will only be considered when one of the following exceptions apply:
 - There are no willing or able private charter operators;
 - For special events the private operators are not capable of providing the service;
 - When there is a formal agreement regarding the provision of charter services between the recipient and all private charter operators who have been identified to be willing and able; and
 - For government or certain non-profit organizations, if the trip involves a significant number of handicapped persons, or if the organization is a qualified social service agency, or if it receives public welfare assistance funds whose implementation may require transportation services.

- All requests for Charter Service must be approved by the Chief Executive Officer and may require a waiver from the Federal Transit Administration. Petitions for a waiver should be requested in writing 90 days in advance of the event whenever possible.

- The rates for charter service shall equal or exceed the annual fully allocated cost, including depreciation, of providing charter bus operations, and Metro shall deduct the mileage and hours from the useful life of the buses.

- The operation of charter service also must comply with relevant state laws, including Section 30630.5 of the California Public Utilities Code.

L. Vehicle Assignments

Metro's goal is to ensure a consistent basis for assigning vehicles to facilities meets operating needs at a minimal cost and improves quality of service. This policy ensures there is a consistent basis for assigning vehicles to facilities that meet operating needs at a minimal cost and improves quality of service.

Buses

- Buses will be assigned to individual facilities on the basis of vehicle size requirements for lines supported by each facility.

Light Rail

- Light Rail cars will be assigned to individual lines on the basis of compatibility of vehicle controllers with each line's signal system.

- The number of vehicle types/manufacturers will be kept to no more than two at any facility to minimize parts storage and maximize maintenance expertise.

Heavy Rail

- Assignment policy is not applicable to Heavy Rail. Red and Purple Lines operate out of the same division and both are operated by the same vehicle type.

3.3 Customer Information & Amenities

Providing customer information instructs both regular riders and infrequent riders on how to use transit as a viable mode of transportation to and from their destinations. The PRC determined that clear, concise, and timely information is an important adjunct to service quality, particularly when bus and rail services are not operating as planned. Amenities aid in the comfort and security of riders.

Customer Information

Passengers need to know how to use transit: where to go to access it, where to alight to access their destination, whether transfers are required, and when transit services are scheduled to depart and arrive. Regular and even infrequent users particularly require this information about specific routes when they need to travel to a location they rarely visit or that is new to them. Information must be provided in accessible formats. Metro provides customer trip planning and help information via telephone, through in-person customer service representatives, on-board announcements, mobile device applications and text/SMS messaging, by mail, online at the metro.net website, and by email.

- **At Transit Infrastructures**, such as shelters, signs directing motorists to Park & Ride lots, and bus stop signs that indicate the presence of service to people not currently using transit.
- **Audible Announcements** at bus stops, rail stations and on board vehicles to assist not only passengers with visual impairments but also passengers unfamiliar with the route or area.
- **Online Information** available 24-hours to anyone with Internet access such as:
 - NEXTRIP's next bus arrival (detour notices should be posted on this service, Metro's website, as well as other social media outlets)
 - Google Transit
 - Route Maps & Timetables, Fare Information, and Trip Planner

2016 Metro Transit Service Policies & Standards

- Specialized Guides (Bikes, Riders with Disabilities, Safety & Security)
 - Commuting Information (Carpools, Vanpools, School Pools, and Employer Programs)
 - News and Media Information
 - Latest Projects and Programs
 - Contact Information
 - Special Event Information
 - Social Media Accounts
-
- **Next Bus or Train Real-Time Information**, both audible and visual, to reassure when the next scheduled vehicle will arrive. This should also include information on detours. Next Bus is only one of many service applications now available for the smart-phone or tablet user of social media.
 - **Printed and Distributed Information**, such as timetables, maps, service change notices, rider newsletters, etc., preferably available at a number of locations.
 - **Posted Information**, such as system maps, bus cubes posted at stops, stations, and on-board transit vehicles.
 - **Route Numbering Convention** at stops and transit vehicle head signs to assist passengers to quickly identify what stops to wait at and what transit vehicle to board related to printed and posted information. See Appendix C.
 - **Way-finding** is the process of communicating information to support our patrons with the ability to navigate through the use of signage, system/route maps, kiosks, bus cubes, directions, etc. so they can easily determine where they are, where they want to go, and how to get there.
 - **Visual Displays** to assist passengers with hearing impairments and to supplement on-board announcements that may be muffled by other noise.

Customer Amenities

Customer amenities are those elements provided at a transit stops, transit centers, and station stops to enhance comfort, convenience, and security. Metro will provide customer amenities where applicable and resources are available. In some instances, Metro will coordinate with municipalities to provide the appropriate amenities. Amenities include items such as shelters,

2016 Metro Transit Service Policies & Standards

benches, vending machines, trash receptacles, lighting, restrooms, and telephones.

- **Benches** provide comfort for waiting passengers, help identify the stop or station, and provide an affordable alternative to shelters.
- **Elevator/Escalators** provide accessibility for those who otherwise cannot use stairs to elevated or lowered station stops.
- **Lighting** increases visibility, security, and discourages misuse of bus stops when transit operations are not in service.
- **Public Restrooms** may be provided at major transit centers and maintained for public safety and convenience.
- **Shelters** provide comfort for waiting passengers, protection from climate conditions, and help identify the stop or station. Metro does not own or install benches and shelters, but will coordinate with local jurisdictions on their placement where appropriate.
- **Telephones/Intercoms** provide access to transit information and emergency services.
- **Trash receptacles** provide a place to discard trash and contribute to keeping bus stops and surroundings clean. Trash receptacles are placed and maintained by individual municipalities at bus stop locations.

Rail Stations & Major Off-Street Bus Facilities

2016 Metro Transit Service Policies & Standards

Metro is committed to providing a minimum set of passenger amenities at all rail stations and major Metro-owned off-street bus facilities that allow for passenger boarding as summarized in Table 3.5. This standard ensures consistency across the system at these locations.



Patsaouras Plaza Transit Facility

2016 Metro Transit Service Policies & Standards

Table 3.5 *Passenger Amenities*

Amenity	Service Type	Allocation
Shelters:	Heavy Rail:	n/a
	Light Rail:	At least 80 linear ft. per bay
	Bus:	At least 6 linear ft. per bay
Seating:	Heavy Rail:	At least 12 seats
	Light Rail:	At least 10 seats
	Bus:	At least 3 seats per bay
Info Displays:	Heavy Rail:	At least 12
	Light Rail:	At least 10
	Bus:	At least 3
LED Displays:	Heavy Rail:	At least 8 arrival/departure screens
	Light Rail:	n/a
	Bus:	n/a
TVMs:	Heavy Rail:	At least 2
	Light Rail:	At least 2
	Bus:	n/a
Elevators:	Heavy Rail:	At least 2
	Light Rail:	At least 1 for elevated/underground
	Bus:	At least 1 for multi-level terminals
Escalators:	Heavy Rail:	At least 4 (2 Up/2 Down)
	Light Rail:	n/a
	Bus:	n/a
Trash receptacles:	Heavy Rail:	At least 6
	Light Rail:	At least 2
	Bus:	At least 1 per 3 bays/2 per facility

When transit service is not provided near one's origin, driving to a Park & Ride lot or riding a bicycle to transit may be viable alternatives. Park & Ride lots and bicycle storage are especially important amenities for transit riders.

- **Park & Ride/Station Parking Facilities** provide a place for transit riders to park their cars before boarding a bus or train. Park & Ride facilities are usually provided at station stops or transit centers, such as the Metro El Monte Station, Harbor Gateway Transit Center (formerly Artesia Transit Center), and at various rail stations. Park &

2016 Metro Transit Service Policies & Standards

Ride lots also can be found in suburbs to serve as a staging area for commuter riders.

- **Bicycle Storage** may be provided at transit stations where demand exists and space allows, and on transit vehicles. Bicycle racks and lockers may be provided at transit center and stations. On transit vehicles, bicycles may be transported on bus-mounted racks located in front of a bus or on board a rail car in designated spaces. Bike racks provide a simple, relatively low-cost approach and can hold a large number of bicycles in a relatively small space, but bicycles are subject to potential damage and theft. Enclosed bicycle lockers provide added



protection from theft and from weather, but are more costly and require more space.

Bicycle Lockers at North Hollywood Red Line Station

SECTION 4: SERVICE PERFORMANCE EVALUATION

Historically, Metro primarily used a Route Performance Index (RPI) to determine a route's performance relative to other similar services using Office of Management and Budget's Annual Budget Projections (Section 4.2). However, in 2009, Metro developed a more comprehensive internal monitoring process that isolates and measures a set of attributes that better gauges a transit line's performance in its goal of providing high-quality transit services that are efficient and effective (Section 4.1). In December 2011, the Metro Board adopted a set of service standards and policies designed to improve the customer experience. These have been incorporated into Metro's Service Performance Indicators.

4.1 Service Performance Indicators

In 2009, Metro introduced a more comprehensive internal monitoring process that focuses on four core service attributes using ten performance indicators. Four of the ten performance indicators, specifically Accessibility, Headways, In-Service On-Time Performance (ISOTP), and Passenger Loading, were revised and adopted as service standards by the Metro Board in December 2011, replacing the corresponding four performance indicators approved in the 2011 TSP.

Metro's Service Planning & Scheduling Department provides quarterly analytical reports that measure four core attributes. Lines are analyzed according to their service type, nine specific time periods, and days of operation (weekday, Saturday, and Sunday). This analysis allows staff analysts to focus on the performance of a line by time period.

Availability

Two indicators are used to measure the extent to which transit service is available.

- **Accessibility:** Service is to be provided within one-quarter mile of 99% of Census tracts within Metro's service area having at least three households per acre and/or at least four jobs per acre. Fixed-route service provided by other operators may be used to meet this standard. This standard ensures the availability of fixed route service to virtually all residents of Metro's service area while limiting duplication of service by using services operated by others to achieve the standard.
- **Connectivity** states that direct transfers should be available for all Rapid-to-Rapid and Local-to-Local connections.

Quality

Quality is important in retaining existing customers and attracting new ones. Two indicators are used to measure quality:

- **In-Service On-Time Performance (ISOTP):** This standard ensures a high level of service reliability. On-time performance is defined as departing no more than one minute early and five minutes late at all time-points along a route. Currently the ISOTP target is set at 80%. Ninety percent of lines should achieve this standard at least 90% of the time.
- **Customer Complaints** monitors the frequency of customer complaints per 100,000 boardings. The poorest 15% of bus lines in each service type receive added scrutiny.

Quantity

Quantity is important in establishing minimum service levels for any service operated as well as ensuring that demand is adequately served when higher volumes of patronage are achieved. Two performance indicators are used to determine if adequate service levels exist given the demand.

Headway/Frequency of Service: The headway standard provided for the maximum scheduled gap (in minutes) between trips in the peak direction of travel at the maximum load point of a line by time of day should not be exceeded for at least 90% of all hourly periods as summarized in Table 4.1.

Table 4.1 *Maximum Headway by Service Type*

Service Type	Peak	Off-Peak
Heavy Rail	10	20
Light Rail	12	20
BRT	12	30
Rapid	20	30
Express	60	60
Limited	30	60
Local	60	60
Shuttle	60	60

Bus & Rail Passenger Loading Standard: Passenger loading standards have been developed to ensure there is sufficient service capacity on Metro Bus and Rail service. The loading standard for bus is based on the maximum average ratio of passengers to available seating per vehicle size (i.e. 40-foot,

2016 Metro Transit Service Policies & Standards

45-foot, and 60-foot buses). The loading standard for rail is based on the maximum average ratio of passengers per seat by service type (i.e. Heavy Rail and Light Rail). Table 4.2 summarizes load factors for other major operators and serves as a yardstick against which the standards used by Metro can be measured.

2016 Metro Transit Service Policies & Standards

Table 4.2 Peak Period Loading Standards: 40 Foot Bus

Property	Peak Loading Standard (Based on seats)	Off-Peak Standard (Based on seats)	Comments
Philadelphia (SEPTA)	1.59		Unspecified off-peak
Seattle (King County)	1.5	1.25	No trip can have standing load for 20 minutes or longer
Chicago (CTA)	1.3	1.0	
San Francisco (MUNI)	1.2	1.0	
Boston (MBTA)	1.4	1.0	
Washington, DC (WMATA)	1.2	1.0	
San Diego (MTS)	1.5	1.0	
Denver (RTD)	1.25	1.0	
New York City (NYCT)	1.5	1.40	
Dallas (DART)	1.5	1.0	

Source: Staff survey of properties 2015

- **Bus Passenger Loading Standard** expresses the maximum average ratio of passengers to vehicle size and frequency by direction for a one-hour period should not be exceeded for at least 95% of all hourly periods. Metro revised its loading standards based on recommendation of the APTA Peer Review Committee and the PRC. The revised set of load factors considered frequency of service as well as seated capacity of a 40-foot, 45-foot, or 60-foot vehicle. The revised policy also accounted for differences between peak and non-peak operations. The rationale for this change was to recognize that a single load factor does not cover the full range of circumstances confronting a passenger. For example, on routes where the frequency of service is 60 minutes, accepting a load factor of 130% of a seated load at all times throughout the day means that the passenger may experience severe overcrowding or worse, be unable to board the bus and be forced to wait another hour for service⁹.
- **Computation of the Average Daily** load is important in determining the frequency of service. The headway is dependent upon the size of the vehicle and the load factor (standees based on a ratio of passengers to available seats) as well as the maximum peak load that

⁹ The 2011 Transit Service Policy, as adopted by the Metro Board in January 2011, increased the Load Factor from 1.2 to 1.3. At the end of the Consent Decree in 2010, load factors were changed from 1.0 to 1.2. Even at that, Metro Load Factors were below other North American operators as shown in Table 4.2. The standards have been modified in the 2016 Policy document to be more in line with the accepted standards exemplified by other large metropolitan operators.

has to be satisfied. Metro determines the maximum peak load by summarizing data for the days of service (Weekday, Sat., or Sun.) and then computes both the average and arithmetic mode for a given period. For lines with low levels of service, the higher value is then selected for the scheduling computation. All other services will use the arithmetic mode unless the values are too diverse, in which case the low service line approach would be used. The arithmetic mode is used rather than the average so that the most common peak loads by time period can be used to determine minimum service levels required. Using the mean for all days of service has resulted in an undercount for some service. This is because all days are used to generate the average, including very low passenger demand days such as rain days, days with special events, semi-holidays and other events. Having staff determine which days to exclude for which bus lines could lead some to speculate that Metro is inappropriately selecting high or low ridership demand days. By using the mode average for all service days, this perception is avoided.

Table 4.3 *Loading Standards with Approximate Passengers per Seat Equivalence*

Weekday AM and PM Periods					Off-Peaks and Weekends				
Frequency Range in Minutes	Psgrs. / Seat	Bus Types			Frequency Range in Minutes	Psgrs. / Seat	Bus Types		
		40 ft.	45 ft.	60 ft.			40 ft.	45 ft.	60 ft.
1 - 10	1.40	56	65	80	1 - 10	1.30	52	60	74
11 -20	1.30	52	60	74	11 -20	1.25	50	58	71
21 - 40	1.20	48	55	68	21 - 40	1.10	44	51	63
41 -60	1.10	44	51	63	41 -60	1.00	40	46	57
60+	1.00	40	46	57	60+	0.75	30	35	43

Shaded area presents current load factor standard applicable at all times.

This table replaces the all-day 130% standard with one that varies by peak / off-peak and schedule frequency.

- **Rail Passenger Loading Standard** expresses the maximum average ratio of passengers to seats by service type and by direction for one-hour period by time of day should not be exceeded for at least 95% of all hourly periods as summarized in Table 4.4.

Table 4.4 *Passenger Loading Standards by Service Type*

Service Type	Peak Psgrs. / Seat	Off-Peak Psgrs. / Seat	Seats per Rail Car	Peak Max. Psgr. Onboard	Off-Peak Max. Psgrs. on Board
Heavy Rail	2.30	1.60	54	124	86

2016 Metro Transit Service Policies & Standards

Light rail	1.75	1.25	76	133	95
------------	------	------	----	-----	----

Effectiveness

Effectiveness measures are used to ensure that service is provided in the most cost-effective manner given scarce resources. Four performance indicators are used to measure effectiveness and are analyzed by service type and time of day.

- **Boardings per Service Hour** measure the level of passenger activity, or passenger turnover, during each hour of operation. The poorest 15% of bus lines in each service type are reviewed in detail.
- **Cost per Passenger Mile** measures the cost effectiveness of the service provided. The poorest 15% of bus lines in each service type are reviewed in detail.
- **Passenger Miles per Seat Mile** establishes the extent to which provided capacity is actually used. The poorest 15% of bus lines in each service type are reviewed in detail.
- **Route Performance Index** should be 0.60 or greater by service type (Section 4.2 provides more details).

4.2 Route Performance Index

The Route Performance Index (RPI) is a conventional industry measure used to ensure Metro services are effective and provide a reasonable return on investment. The RPI is designed to provide an objective measure of a bus route's performance relative to other similar types of service. The index is based on system ridership and financial targets from the current fiscal year Metro Budget.

This measure is applied to all Metro bus lines that have been in operation for more than one year. The RPI is used to identify under-performing lines. Specific corrective actions are taken during the service change process. Corrective actions may include marketing, service restructuring, implementing an alternative service, or discontinuation of service.

Defining RPI Variables

The RPI considers the following three variables in creating the index. No weight is given to an individual measure; rather the selected statistics represent all facets of the operation in terms of cost efficiency, service effectiveness, and passenger use.

- **Utilization of Resources:** Passenger Boardings per Revenue Service Hour (RSH) is used as a measure to determine how effectively resources are used on a given line. This measure is determined by

dividing the total number of boardings by the RSHs operated. A route having a higher number of boardings per RSH represents a better utilization of resources such as buses, operators and fuel.

- **Utilization of Capacity:** Passenger Miles per Seat Mile is the measure used to evaluate how well the seating capacity of the system is being used. Passenger miles are calculated by multiplying the average distance traveled per passenger by the number of passengers using the service. Seat miles are calculated by determining the number of seats per vehicle by the number of service miles operated. A higher resulting number indicates greater utilization of system capacity.
- **Fiscal Responsibility:** Subsidy per Passenger is the measure for fiscal responsibility. Subsidy refers to the amount of public funding required to cover the difference between the cost of operation and the passenger revenues collected. Higher subsidy services require more public funding support.

The formula for calculation of the RPI for each Metro Bus line is as follows:

$$\text{RPI} = ((\text{Psgr./RSH/System Avg.})+(\text{Psgr. Miles per Seat Mile/System Avg.})+(\text{Subsidy per Psgr./ System Avg.}))/3$$

Lines with an index of 1.0 perform at the system average, while lines with an index of less than 1.0 perform below the average. Lines with an RPI lower than 0.6 are defined as performing poorly and targeted for corrective action. Lines that have been subjected to corrective actions and do not meet the 0.60 productivity index after six additional months of operation may be discontinued, subject to Metro Service Council or Board approval.

The RPI is calculated and reported quarterly by Metro's Service Planning & Scheduling Department. The performance measurement standards for each route category are set annually relative to the percentage improvement of overall system performance relative to the previous year's performance. This percentage improvement will be based on the performance objectives outlined in the Metro Annual Operating Budget.

4.3 Service Change Performance Evaluation

Schedule adjustments to bus or rail should be evaluated shortly after implementation to determine if there are any obvious issues. This should include line rides and visits to the operating divisions to receive comments and recommendations from passengers, operators and supervisors. Appropriate adjustments should be made as required. After about three

months of operations, the schedules should be evaluated in detail to begin the process of schedule adjustments for the next service change cycle.

Route modifications to bus service should also be evaluated shortly after implementation similar to the schedule evaluation outlined above. The overall goals of the service changes such as reducing costs, improving connections, increasing bus speeds, and increasing ridership, among others, should have near term goals that are established prior to the service change process. At about 6 months after service implementation, the performance of the changes should be evaluated relative to the established goals. Remedial actions, if necessary, should be developed and considered for the next service change cycle.

4.4 Service Policy Regarding Realignment of Metro and Municipal Bus Service

The regional public transit network consists of 17 “Included or Eligible” fixed route operators (including Metro). Included operators (and routes) are those that were operating within LA County in 1971 at the time of adoption of the TDA/STA statute. Eligible operators (and routes) are those added to the Formula Allocation Procedure (FAP) since that time.

Much of the funding for operation of Included or Eligible fixed route public transit service in Los Angeles County is distributed according to an adopted FAP. The FAP allocates sales tax receipts for public transit each fiscal year in support of public transit throughout the region. Many of the Included and Eligible systems operate under the guidelines of the “reserve service areas” established in 1971.

Since that time, Metro’s network of lines spanning Los Angeles has changed considerably, especially with the passing of Proposition A (1980 sales tax initiative). Municipal operators have also grown, providing an expanded route network that has improved connections to Metro’s regional lines. In addition, there are numerous Local Return fixed route transit providers who are not eligible for FAP funding, but instead are funded through Propositions A and C (1990 sales tax initiative), and Measure R (2008 sales tax initiative). These Operators are funded as “Local Return” operators (see Appendix F for a list of operators funded as Local Return and/or Included/Eligible Municipal operators).

Since the Blue Ribbon Committee convened in 2010 provided policy guidance regarding Metro’s transit network, Service Planning staff has considered service modifications that would best fit with each of the major transit providers. The policy guidance states that the network should be well integrated, coordinated, reduce service duplication and simplify service.

2016 Metro Transit Service Policies & Standards

Therefore, the evaluation of transit corridors for consideration to be operated in the future by another operator should include:

- Existing performance relative to the system average;
- Value to the customer through integration into an established nearby transit provider;
- Net cost to each operator and the region;
- Completion of another operator's route network;
- Provide improved connections to a Municipal Operator's established network;
- Impacts to existing and projected ridership;
- Generation of a net cost savings to Metro based on Metro's calculation of the FAP impacts for all service realignment proposals.

If, as a result of the analysis of the proposed alignment, change is adopted and Metro's service is reduced, Metro should reinvest at least half of the net savings (operating cost less passenger and FAP reduction) to improve service on Metro's core network of regionally significant lines in the service area from which the savings were drawn.

Any significant service modifications will be subject to review under Title VI of the Civil Rights Act of 1964, as amended, the approval of the appropriate Metro Service Council(s) and the local transit provider's Board of Governance, and must be in compliance with local, regional, and labor legislation or agreements. Finally, the agency that assumes service will be required to maintain or improve the days, spread, and frequency of the existing service for at least a one-year period. In addition, the assuming agency must be a participant in the regional TAP program to minimize fare change impacts.

Patsaouras Plaza Dodger Stadium Shuttle Operation 2015

SECTION 5: IMPLEMENTING THE PLAN

Taking advantage of the foregoing principles and standards, this section identifies the actions necessary to implement the recommendations of the APTA Peer Review Committee and the PRC in relation to the Strategic Bus Network Plan. At the core of all of these elements is the development of a set of high frequency lines that provide regional service and connections with minimum 15-minute peak headways for all services addressed in the plan. Figure 5.1 displays the existing network of 15-minute services and is overlaid by additions to the plan needed to close gaps or make connections not currently offered as identified by the PRC. All identified service additions were reviewed by Service Planning staff and prioritized into four categories A - D reflecting the importance and ease of implementation. The top two priority groupings were included on the map for presentation to the PRC.

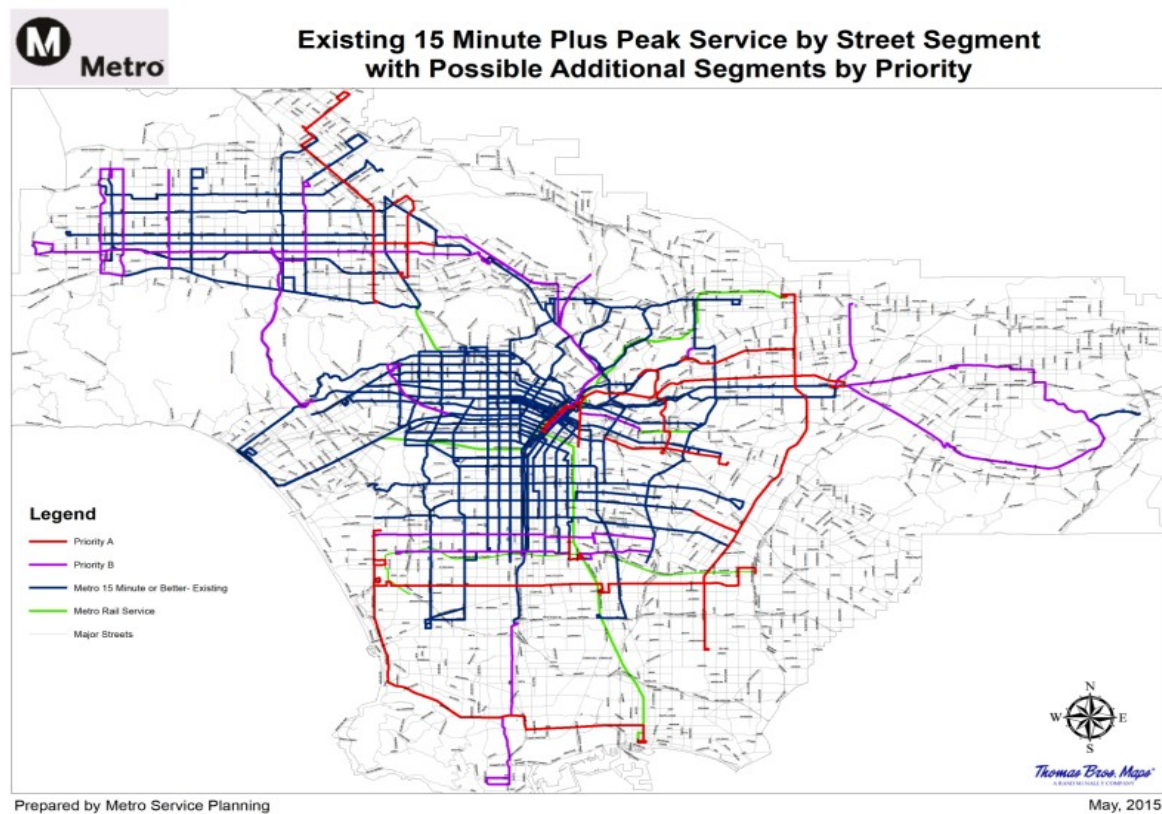

Figure 5.1 Existing 15 Minute Plus Peak Service by Street Segment with Possible Additional Segments by Priority

Taken together, without any reconfiguration of the remainder of the service network, priorities A and B together would add approximately unbudgeted 116,000 RSH.

2016 Metro Transit Service Policies & Standards

Forecasts of RSH for the agency reflects a flat and/or slightly declining number of hours allocated to the Local and Rapid Bus portions of the system. Bus Rapid Transit Hours, conversely, are expected to grow with the projected conversion of a portion of Line 720 Rapid to BRT in FY16. The Orange and Silver Lines are in the BRT service category although the RSH for them are broken out. Table 5.1 presents the projected bus RSH through FY20.

Table 5.1 *Bus Revenue Service Hours by Service Type*

Service Type	FY15	FY16	FY17	FY18	FY19	FY20
Local + Rapid	6,327,663	6,227,663	6,227,663	6,227,663 ¹⁰	6,265,434	6,245,434 ¹¹
Silver Line	84,380	84,380	84,380	84,380	84,380	84,380
Orange Line	130,516	130,516	130,516	130,516	130,516	130,516
Wilshire BRT		100,000	100,000	100,000	100,000	100,000
Contracted	519,176	519,176	519,176	519,176	519,176	519,176
Total	7,061,735	7,061,735	7,061,735	7,061,735	7,099,506	7,079,506

Source: OMB, FY16 Adopted Budget

In addition to existing services, new rail lines including Expo Phase 2, Foothill Gold Line Extension, Regional Connector, and the Crenshaw Corridor should be considered as enhancements to the system. These new lines will expand the travel horizons for residents and visitors to Los Angeles County.

For the extensions to the Gold and Expo lines, Metro Bus service is impacted only slightly as the extensions fall mostly in areas operated by Foothill Transit or Santa Monica Big Blue Bus. However, staff will need to complete a thorough review for each rail line to see if there are opportunities to make simpler connections to the rail system, minimize duplication and thereby create a pool of RSH savings for reinvestment into the base network in support of the 15-minute service plan. In the case of the Crenshaw Line, it is anticipated that parallel Rapid service will be reduced significantly and RSH so identified will be made available to reinvest in the system. Since the budgeted RSH remain flat and the total number of RSH fixed, gaining savings for reinvestment elsewhere in the system is of significant benefit.

¹⁰The Wilshire 720 Rapid is scheduled using 213,340 RSH. The 100,000 RSH shown under BRT is for the estimated portion of the line that will operate as a BRT in the newly opened bus lanes. Hence, the total RSH is still 213,340 RSH; the operation is shown as 113,340 RSH in Local + Rapid and 100,000 RSH in BRT.

¹¹20,000 RSH reduced for implementation of Crenshaw Line.

5.1 Changes to the Rapid Bus Network

When originally established, the Rapid Bus network was based on specific warrants that were developed to maintain the attractiveness of the lines because of their inherent speed advantage over the underlying Local service. Over time, as routes were implemented, the agency fulfilled constituent requests for additional service stops which had the deleterious effect of reducing service speed. Further, the distinctive street furniture and informational displays were never fully implemented such that other than Lines 720 and 750, the majority of Rapid services use identified street stops. Furthermore, where lines lost ridership along with their speed advantage, services were adjusted below the warrants and standards such that some lines have been cancelled or reduced to limited stop operation and peak headways widened to 10 to 30 minutes at maximum.

The plan assumes that the Rapid Bus Lines would be brought up to meet the headway warrants of 15-minute peak and 30-minute off-peak maximums. Today, 1,040,075 Bus RSH are operated by the 19 Rapid Bus routes. Bringing these routes to a 10-15 minute peak / 20-30 minute base headways for Rapid Bus service would require the addition of unbudgeted 142,127 Bus RSH.

5.2 Goals and Objectives

The service planning process includes the following goals and objectives:

- **Simplify Bus Routes** – Existing bus routes and bus stop boardings will be reviewed to determine if more intuitive routes would increase patronage, reduce travel time, improve on-time performance and reduce accidents.
- **Improve Travel Speed** – Travel speeds continue to decrease along Metro routes. Bus stop spacing, bus route design, and potential faster bus boarding techniques will be inventoried for improvements.
- **Re-Invigorate the Metro Rapid Network** – Since the inception of the Metro Rapid Program in year 2000, Rapid lines have been added, and some deleted or modified. These lines will be analyzed to determine their need, regional importance, improvements, and possibly identify new Rapid lines.
- **Improve connectivity to the Rail/BRT/Rapid and Express services network** – Routes will be reviewed to determine how they might better serve the network. As an example, a new Line 162 (part of Line 163-Sherman Way) connected peak period Sherman Way

residents directly with the North Hollywood Metro Red and Orange Line Stations, thereby eliminating a transfer. Due to the popularity of the route extension, Line 162 now operates all day to North Hollywood, providing improved connections to this important transportation hub.

- **Improve bus lines of regional significance** – Existing headways, connectivity and patronage will all factor into identifying and recommending improvements to routes of regional significance.
- **Review the owl service network** – Metro’s owl network has changed little over the decade, and with growing rail and BRT services (now operating until 2:00AM on Friday and Saturday nights), local services will be reviewed to determine proper alignment with changing late night travel patterns.
- **Improve service quality** – On-street and Bus Operations Control management procedures will be reviewed towards a goal of improving line management, on-time performance, and accident reduction.
- **Improve the cost model to better fit service/vehicle types** – Currently, Metro operates a variety of bus sizes (32 to 60 foot), and rail operates light rail and heavy rail vehicles. The existing cost model will be reviewed to determine if it should be modified to account for the differing types of operated services.

5.3 System and Service Evaluation

Services are evaluated based on segments (geographic, time of day, and day of week) using evaluation criteria outlined in Metro’s Transit Service Policy as well as other pertinent measures including ridership, boardings per service hour, subsidy per boarding, peak load factor, and on time performance. Services that are inconsistent with demand, or do not meet criteria should be identified for reduction, discontinuation, or restructuring. Services that have potential for exceeding existing performance should be identified for possible enhancements as should markets that are currently not well served. The following priorities should be considered when restructuring the Metro system:

- **Priority 1** – Restructure services that are duplicative with Metro Rail as well as Municipal and Local Return operator services. Such services should be identified for reduction or reallocation to achieve greater productivity and cost efficiency.
- **Priority 2** – Restructure services to increase system speed, on-time performance, and balance loads.

- **Priority 3** – Restructure remaining services (constrained by existing budget) based on the service concept and to address major gaps and deficiencies. Prioritize these service adjustments.
- **Priority 4** – Develop new services (unconstrained) to address all gaps and deficiencies. Prioritize these new services.

Significant changes to municipal operator services, including Santa Monica Big Blue Bus, Culver City Transit, and Foothill Transit are incorporated into the evaluation of existing and new services as possible enhancements to address identified gaps or deficiencies in service.

5.4 Develop Service Draft Restructuring Plan

Each service adjustment proposed will be described with the following information, at a minimum:

- Description of service, including rationale for service
- Line map showing routing, exact layover locations, and stops
- Service span (hours, days, and seasons)
- Headway (time period, days, and seasons)
- Estimated ridership
- Financial, operating and performance statistics
- Vehicle requirements

Supporting facilities and programs recommended as part of the service restructuring will be described. The restructuring plan will focus on impacts to ridership, costs, productivity, cost effectiveness, quality of service (e.g. on time performance and travel time), vehicle requirement, staffing requirements, and operational efficiency.

2016 Metro Transit Service Policies & Standards



Metro Celebrates 25 Years of Rail Service. Photo courtesy of Scott Page

SECTION 6: SERVICE CHANGE PROCESS

In accordance with contractual agreements with the Sheet Metal Air, Rail and Transit Union (SMART)¹², bi-annual service changes will be implemented in June and December. Metro service changes are conducted to modify service based on patronage demand, running time adjustments, and budget considerations. Table 6.1 is an established service change timeline. A service change process work flow also is provided in **Appendix G**.

Table 6.1 *Service Change Timeline*

Key Activities	Required Lead Time (Months Prior to Implementation)
Initiate Planning Process	12
Develop Preliminary Recommendations	7-8
Impact Analysis for Proposed Changes	6-7
Title VI Equity Analysis on Major Service Change and Fare Change Proposals	5-7
Service Council Review and Input	6-7
Confer with Labor Relation and Union Representatives	6-7
Public Review and Input	5
Finalize Service Change Program	4-5
Program Approval	3-4
Develop New Service Schedules	2-4
Print Public Time Tables and Operator Assignments	1-2
Fabricate Decals for Bus Blades	1-2
Print Bus Cubes/Take-One Bus Inserts	1

Metro Service Councils provide a forum for the community and local municipal operators to express needs and priorities, and evaluate opportunities and service coordination issues. Service change programs are developed based on input generated by a wide variety of sources including customer and employee input, service restructuring studies, requests from other local operators, and performance monitoring results. The service change process includes public review of the proposals, a technical evaluation of ridership impact, and Title VI equity analysis (discussed in Section 5.1).

¹² The United Transportation Union (UTU) merged with the Sheet Metal Workers Union in 2014 to form SMART.

Other factors considered are service performance, availability of alternatives, and mitigation strategies. As part of the evaluation process, resource impacts including in-service hours and vehicles also are tracked to ensure compliance with budget parameters. Below is a summary of the purpose of an evaluation on proposed service changes:

- Define and evaluate the impact on riders
- Determine whether a proposed major service change or fare increase will have disparate adverse impact on minorities or a disproportionate burden on low-income individuals by performing a Title VI Equity Analysis
- Alternatives will be considered if a disparate adverse impact to minorities or disproportionate burden on low-income individuals are identified
- Staff will develop appropriate mitigation measures if needed
- Determine whether or not a public hearing is required

Changes to the rail system occur less frequently. They generally relate to the opening of a new line or adjustments to the frequency or hours of operation for existing service. Changes in rail and bus service follow the same planning and implementation process.

6.1 Title VI Equity Analysis

In accordance with FTA's Title VI Circular 4702.1B "Title VI Requirements and Guidelines for Federal Transit Administration Recipients" (Effective October 1, 2012), Metro's Administrative Code was revised to incorporate FTA's requirements under Title VI. The Metro Board adopted the updated Administrative Code in January 2013. Based on this Circular, Metro is required to perform a Title VI Equity Analysis on all proposed major service changes or fare changes prior to its implementation. The goal is to ensure there is no *disparate adverse impact* to minorities or *disproportionate burden* on low-income individuals created by a major service or fare change. The following definitions and criteria can be found in Metro's Administrative Code in Chapter 2-50 Public Hearings Subsection 2-50-005 Definitions:

- **Disparate Adverse Impact** refers to a facially neutral policy or practice that disproportionately affects members of a group identified by race, color or national origin and the policy lacks a substantial legitimate justification including one or more alternatives that would serve the same legitimate objectives but with less disproportionate effects on the basis of race, color or national origin.
- **Disproportionate Burden** refers to a neutral policy or practice that disproportionately affects low income populations more than non-low

income populations. A finding of disproportionate burdens for fare and major service changes requires Metro to evaluate alternatives and mitigate burdens where practicable.

- **Major Service Changes:** A *disparate adverse impact* will be deemed to have occurred if the absolute difference between the percentage of minorities adversely affected and the overall percentage of minorities is at least 5% or if there is 20% or greater percent difference between the percentages of these two groups. A *disproportionate burden* will be deemed to exist if absolute difference between the percentages of low-income adversely affected by the service change and the overall percentage of low-income persons is at least 5% or if there is a 20% or greater percent difference between the percentages of these two groups.
- **Applicable Fare Changes:** A *disparate adverse impact* will be deemed to have occurred if the absolute difference between the percentages of minorities adversely affect the overall percentage of minorities is at least 5% or if there is a 35% or greater percent difference between the percentages of these two groups. A *disproportionate burden* will be deemed to exist if absolute difference between the percentages of low-income adversely affected is at least 5% or if there is a 35% or greater percent difference between the percentages of these two groups.

Discretion of the Metro Board of Directors

A *Major Service Change* or *Fare Increase* may be implemented even if the Title VI Equity Analysis determines a *disparate adverse impact* to minorities or *disproportionate burden* on low-income individuals were created by the change. However, the Metro Board of Directors must first ensure these changes meet two tests:

- There is a substantial legitimate justification for adopting the proposed major service change or fare increase, meaning the selected service change or fare increase meets a goal that is integral to the mission of Metro; and
- The selected alternative would have a less severe adverse effect on Title VI protected populations than other alternatives that were studied.

Major Service Change

Metro's Administrative Code in Chapter 2-50 Public Hearings Subsection 2-50-010 defines a major service change as any service change meeting at least one of the following criteria:

2016 Metro Transit Service Policies & Standards

1. A revision to an existing transit route that increases or decreases the route miles by 25% or the revenue miles operated by the lesser of 25%, or by 250,000 annual revenue service miles at one time or cumulatively in any period within 36 consecutive months;
2. A revision to an existing transit service that increases or decreases the revenue hours operated by at least 25% or by 25,000 annual RSH at one time or cumulatively in any period within 36 consecutive months;
3. A change of more than 25% at one time or cumulatively over any period within 36 consecutive months in the number of total revenue trips scheduled on routes serving a rail or BRT station, or an off-street bus terminal serving at least 4 bus routes;
4. A change of more than 20% of the total system revenue miles or revenue hours in any 12 month period;
5. The implementation of a new transit route that results in a net increase of more than 25,000 annual revenue hours or 250,000 annual revenue miles; and,
6. Six months prior to the opening of any new fixed guideway project (e.g. BRT line or rail line) regardless of whether or not the amount of service being changed meets the requirements in 1 through 5 above.

Fare Changes

Metro's Administrative Code in Chapter 2-50 Public Hearings Subsection 2-50-015 addresses fare change equity evaluation and provides the following guidance:

1. A Fare Equity Analysis shall be prepared for any fare change (increase or decrease). This includes, but is not limited to permanent fare changes, temporary changes, promotional fare changes and pilot fare programs. The analysis will evaluate the effects of fare changes on Title VI protected populations and low-income populations. The analysis will be done for fares not available to the general public such as special discount programs for students, groups or employers.
2. If fare changes are planned due to the opening of a new fixed guideway project, an equity analysis shall be completed six months prior to opening of the service.
3. Each Title VI Fare Equity Analysis shall be completed and presented for consideration of the Board of Directors in advance of the approval of the proposed fare or fare media change by the Board of Directors. The

Equity Analysis will then be forwarded to the FTA with a record of action taken by the Board.

4. A Title VI analysis is not required when:
 - a) A change is instituted that provides free fares for all passengers;
 - b) Temporary fare reductions are provided to mitigate for other actions taken by Metro;
 - c) Promotional fare reductions are less than six months in duration. An equity analysis must be conducted prior to making any temporary fare change into a permanent part of the fare system.

6.2 Public Outreach

Prior to the public hearing, a number of public outreach efforts are made so that the greatest number of patrons may respond to the changes at either a public hearing or by submitting written comments at a hearing, or via email, mail, or fax. In accordance with Metro's Administrative Code in Chapter 2-50 Public Hearings Subsection 2-50-025:

1. Any public hearing required by Section 2-20-020 shall be conducted as set forth in this section.
2. Notice of the hearing shall be published in at least one English language and Spanish language newspaper of general circulation and at least thirty (30) days prior to the date of the hearing. Notice at least thirty (30) days prior to the date of the hearing shall also be published in the neighborhood and foreign language and ethnic newspapers as appropriate to provide notice to the members of the public most likely to be impacted by the proposed action.
3. Notice of the public hearing shall also be announced by brochures in English, Spanish and other appropriate languages on transit vehicles serving the areas to be impacted and at customer service centers.
4. In order to ensure that the views and comments expressed by the public are taken into consideration, MTA staff shall prepare a written response to the issues raised at the public hearing. That response should also include a general assessment of the social, economic and environmental impacts of the proposed change, including any impact on energy conservation.
5. The public hearing related to a recommendation to increase transit fares charged the general public shall be held before the Board of Directors and any action taken to increase the fares charged the general public must be approved by a two-thirds vote of the members

2016 Metro Transit Service Policies & Standards

of the Board of Directors. The Board of Directors may delegate to another body or a hearing officer appointed by the Chief Executive Officer the authority to hold the public hearing related to a change in transit service.

The distribution of information will include line number, line name and route change information and/or fare change proposals. Other public outreach occurs at key transportation centers, bus stops, and bus and rail stations 30 days prior to the public hearing date. This effort reaches patrons, who may not have time to attend a public hearing, and informs them of other communication methods available for filing public comment. Public participation in the public hearing process is an important step in assisting staff and Metro Service Councils in developing and approving final service changes. Table 6.2 is a timeline for public notification activities.

Table 6.2 *Timeline for Public Notification Activities*

Activity	Months Prior to the Service Change
Service Planning staff reviews preliminary proposals.	7
Metro Service Councils set dates of public meetings, publish hearing notices in local newspapers and send LEP and minority communities written notification to elected officials, other operators and key stakeholder groups. Confer with Labor Relations and Union representatives.	5-6
Service Planning staff provides information on proposed changes to the Metro Bus Operators Subcommittee and at quarterly meetings held with the region’s municipal and local operators.	3
Communication Department posts information proposed changes on Metro’s website.	5
Operations staff distributes meeting notices on board vehicles. Public outreach at key transportation centers, bus stops, and on board patron interface occurs as well.	At least one month prior to public hearings
Metro Service Councils conduct public hearings.	4
Metro Service Councils approve final service change program.	3
Communication Department prepares press releases on final program and program brochures are distributed on-board Metro vehicles and other outlets.	1

6.3 Public Hearing Process

Once a Service Change Program has been developed by Metro Service Planning Staff, the Metro Service Councils are asked to set a date, time and place for their public hearings. During the period between publication of the hearing notices and public hearings, each Service Council is provided a detailed presentation on service change proposals and given an opportunity to discuss each of the changes that will be the subject of public comment. Subsequent to each hearing, each Service Council will meet to consider and approve, modify, or deny all proposed service changes. These actions will then be summarized and presented in an informational report to the Metro Board of Directors.

Public hearings are usually held at the same location where the Service Councils hold their meetings, but may be held at other locations at their discretion. Under Metro’s Revised Service Council by-laws, all service changes must be reviewed and approved by their respective Service Council(s). In accordance with Metro’s Administrative Code in Chapter 2-50 Public Hearings Subsection 2-50-020, Metro will hold a public hearing on all major service change or fare change proposals that are subject to a Title VI

2016 Metro Transit Service Policies & Standards

Equity Analysis. These proposals are subject to Metro Service Council and Metro Board approval.

6.4 Implementing Minor Changes on an Interim Basis

Minor service changes are generally route modifications that can be accommodated without impacting the vehicle or operator requirements of the service. Minor service changes do not require a public hearing, but can



be implemented at the discretion of staff.

Metro Silver Line at El Monte Station

SECTION 7: CONCLUSION

Metro's vision is to maintain a world-class public transit operation and meet the challenges related to serving the evolving, diverse needs of passengers, communities, and other transit providers. Metro realizes this is contingent on innovative thinking that stems from a solid base of sound planning principles. To meet the changing needs of a growing population in Los Angeles County, Metro will continue to expand its high-speed bus and rail network across the region under Measure R and the 30/10 Initiative.

As the coordinator of regional transit services, Metro must provide safe, reliable, effective, and convenient services focused on both customer and employee with an emphasis on long-term sustainability. Achieving this delicate balance between maximizing the benefits of service to transit riders, while ensuring that service delivery is efficient and cost effective requires policy guidance and service standards that are designed to target specific levels of productivity, efficiency, and quality.

Given the significant growth in the Municipal and Local Return transit operators and Metro's rail network, Metro's vision can be achieved through better coordination between the various transit service providers, by leveraging the expansion of its rail network, and by reducing service duplication. These measures will make the transit system more efficient and manageable, resulting in better service quality and a simpler, more user-friendly system to use.

In addition, Metro will ensure a Title VI Equity Analysis is performed on all major service change and fare change proposals to determine if these proposals will have a disparate adverse impact on minorities or disproportionate burden on low-income individuals prior to a public hearing. If it is determined that these proposed changes will have a disparate adverse impact on minorities or a disproportionate burden on low-income individuals Metro will make a good-faith effort to mitigate or reduce the adverse impacts by looking for alternatives.

Overall, the 2015 Metro Transit Service Policy establishes a set of performance criteria and standards, provides quantitative tools to evaluate the system, and describes how the service change process will be conducted to ensure the opportunity for feedback to be provided by the various stakeholders. The TSP service design guidelines ensure the transit system developed is consistent with policy guidance approved by the Metro Board of Directors.

APPENDICES

APPENDIX A: 2015 PEER REVIEW COMMITTEE MEMBERS

Citizens Advisory Council

Anne Reid
Dalila Sotelo

Foothill Transit

Doran Barnes
Joseph Raquel

Gardena Transit

Jack Gabig

Gateway Cities Service Council

Gene Daniels
Wally G. Shidler

LADOT

Phil Aker

Long Beach Transit

Shirley Hsiao
Kenneth McDonald

Pasadena ARTS

Valerie Gibson

San Fernando Valley Service Council

Antonio Lopez
Yvette Lopez-Ledesma
Dennis Washburn
Donald Weissman

San Gabriel Valley Service Council

Harry Baldwin
Alex Gonzalez
Dave Spence
Rosie Vasquez

Santa Monica Big Blue Bus

Edward King
Timothy McCormick

South Bay Service Council

Devon Deming
Don Szerlip

Torrance Transit

Kim Turner

Westside Central Service Council

Elliott Petty
George Taule

APPENDIX B: METRO LINE IDENTIFICATION

The purpose of establishing transit service line identification standards is to create a simple way for passengers to identify, locate, and reference Metro services, and thereby make the services easier for patrons to use.

The line identification standards shall be adhered to when identifying Metro Bus and Metro Rail lines by name. The standards shall be implemented across all internal and external mediums including, but not limited to, bus stop signs, bus station signs, vehicle headsigns, time tables, the Metro Transit Trip Planner, HASTUS and ATMS. The descriptions and chart below help explain the standards, and how and when they should be implemented.

General Standards

- Transit service lines will be identified using a combination of line number, destinations (both terminals) and the corridor(s) the line travels along, with the exception of Metro Rail and Metro Liner service which will use the established operational name (e.g., Metro Red Line, Metro Purple Line, Metro Orange Line).
- Acceptable destination names include a city, community, major landmark, transit center or rail station. Street intersections are no longer to be used as a destination, unless the intersection is required to identify short-line service.
- The destination points will be listed in a West to East or North to South order, consistent with how the line would be read on a map.
- Lines that have Downtown Los Angeles as one of the line's end points will list its first, as Downtown LA.
- The name of the line will also list at least one major corridor on which it travels.
- Name abbreviations, street extensions and other topics will be dictated by the Metro Signage Guidelines.

Printed Materials and Electronic Customer Information

- The line will be presented using the full name, listing both the destinations and major corridor(s).
- The printed materials include, but are not limited to, timetables, service change announcements, brochures, system maps, and service reports.
- Electronic customer information includes the line information presented on metro.net and underlying electronic databases such as HASTUS and ATMS.
- The Metro Transit Trip Planner will present the line name similarly to what will be shown on the vehicle headsign and bus stop sign, so patrons can easily locate the appropriate line at the stop.

Bus Stop Signage:

- The line will be presented using the line number, service brand, color and destination point that the vehicle is traveling to in each direction.
- The main corridor(s) will also be listed as well as special service qualifiers including, but not limited to, rush-hour service and weekday-only service.
- Short-line trip destinations will not be shown on bus stop signs.

Vehicle Headsigns

- Headsigns will list the destination in which the vehicle is traveling towards in one frame.
- For short-line trips, the line number and destination shown will be the destination of that trip and not of the entire line.
- When the line is not in service, the sign will read “Not in Service” and display the route number per Operations Notice #09-18.

Automatic Voice Announcements

- External On-Board Announcements:
 - The line will be identified in automatic external voice announcements using the line number and destination point that the vehicle is traveling to in each direction.
 - For short-line trips, the destination noted will be the destination of that trip and not of the entire line.
- Internal On-Board Announcements:
 - When the automatic voice announcement system identifies a stop, the end destination of that line will follow.
 - The stops and stations announced onboard should be consistent with names used on maps, timetables and other printed materials.

Assigning Line Identifiers

It is expected that the standards will be easily applied to the majority of lines; however, it is also understood that exceptions will have to be made for some lines due to unfamiliar end points or corridors. In these limited cases, Service Planning staff and Communications must be in consensus regarding these changes before deciding to deviate from the standards.

Metro Orange Line

2016 Metro Transit Service Policies & Standards

Metro's Bus Line Identification, Route Numbering and Color Conventions

Service Type	Numbering	Primary Route Direction	Color Scheme
Local	1-99	Serves Downtown LA - counterclockwise from NW quadrant.	California Poppy
	100-149	Primarily EW operation in areas S of LACBD	California Poppy
	150-199	Primarily EW operation in areas N of LACBD	California Poppy
	200-249	Primarily NS operation in areas W of LACBD	California Poppy
	250-299	Primarily NS operation in areas E of LACBD	California Poppy
Limited	300-399	Branch of local line.	California Poppy
Express	400-499	Serves Downtown LA -- numbered counterclockwise from NW quadrant.	California Poppy
	500-599	Does not serve LACBD.	California Poppy
Shuttle	601-649	Generally circuitous routing within service area.	California Poppy
	650-659	Generally scheduled service operating point-to-point.	California Poppy
	660-699	Generally serves a rail line within service area.	California Poppy
Rapid Bus	700-799	Usually operated in combination with an underlying local line.	Red
Specialized Services	901	Metro Liner: Orange Line (BRT)	Silver

2016 Metro Transit Service Policies & Standards

910	Silver Line: I-10 and I-110 Express Lanes	Silver
-----	---	--------

APPENDIX C: METRO RAPID PROGRAM SERVICE WARRANTS

Launched in June 2002, the Metro Rapid program began with two demonstration lines – one along Ventura Blvd. in the San Fernando Valley and the other along the Wilshire/Whittier Transit Corridor. Based on the success of these two demonstration lines, the program was expanded across the county. Currently there are 23 Rapid routes – 19 operated by Metro and four operated by local municipal operators.

PROGRAM PRINCIPLE: Improve Operating Speed and Frequency.

PROGRAM GOAL: Minimum operating speed improvement is 20% over existing local service.

Program Element	Program Component	Program Objective
Corridor Alignment	Maximize patronage and minimize costs	Identify core segment of corridor for Metro Rapid operation to maximize patronage (500 passengers per route mile or greater) and minimize operating costs. This includes minimizing corridor turning movements to maximize safe and reliable operating speeds, reliable service, and ease of use among our customers.
	Alignment modification	Changes to the alignment including the addition of short lines and branches require an analysis of impacts on customers, line performance, operating costs, capital costs and impacts to existing and planned transit signal priority systems (TSP).
	Maintenance of operating speed	Maintenance of the Program Goal is required. Corridor vehicle run times will be monitored. Improvements in operating speed are encouraged through improved stop placement, signal priority software, elimination of unproductive stops, introduction of bypass lanes, and improved BOCC and TOS management.

2016 Metro Transit Service Policies & Standards

Stop Location	Station spacing average no less than 0.70 miles	Station spacing should average no less than 0.70 miles per corridor and be based on existing ridership and connections with other bus and rail service. Stations should be located to maximize connectivity with other Rapid, Metro Liner, Metro Rail, and commuter rail stations. Station locations must be planned to accommodate either 45-foot or 60-foot buses.
	Far-side station location	Far-side stop locations are desired to realize TPS and be planned at all intersections for both Metro Rapid and Local service. The only exceptions are where far-side stop locations are not possible within a reasonable walk from the intersection or where nearside locations facilitate access for greater than 75% of the boardings, e.g., intersecting Metro Rail station portals.
	Separation from local stop	Metro Rapid and Local bus stop locations should be located adjacent but not combined with each other wherever practical. This minimizes the confusion of where to wait for service and gives the customer the option of choosing the first bus that arrives. This also improves customer safety by eliminating the back and forth movement between nearside and farside stop locations while waiting for the next bus to arrive.
	Addition of new stop	Stops may be added only if they exceed 250 all-day boardings and alightings (100 boardings if within one mile of line terminal) and as long they will not adversely impact the minimum average stop spacing of 0.7 miles. Added stops require an analysis of impacts on customers, line performance, operating costs, and capital costs.
	Elimination of stop	Stops may be eliminated due to low passenger demand as long as their removal will not result in excessive spacing among the remaining stops along the line. An analysis of impacts on customers, line performance, operating costs, and capital costs is required.
Program Element	Program Component	Program Objective
Transit Priority	All signalized intersections should provide bus signal priority for Metro Rapid	Signal priority should include terminal movements to reduce operating costs.
	Identification of by-pass lane needs	At points of significant delay due to traffic congestion, an analysis will be developed of the feasibility of establishing by-pass lanes for Metro Rapid service.
	Monitor effectiveness of transit priority measures	The effectiveness of the transit priority measures will be periodically analyzed and recommendations will be developed for potential further improvements where warranted. Every effort should be made to ensure that buses with transponders are assigned and that every transponder is working properly.

2016 Metro Transit Service Policies & Standards

Rapid Vehicle Fleet	Metro Rapid lines are assigned one vehicle size, i.e., 40-ft, 45-ft, or 60-ft articulated	The planned service frequency will be based on deployment of a particular size bus and these vehicles will need to be assigned to the particular line and operating Division. Only one size vehicle should be scheduled and operated on each line in order to avoid passenger overcrowding and service bunching.
	Vehicles must be in Metro Rapid livery	Metro Rapid vehicles may be operated only on Metro Rapid routes. On the rare occasion that a red bus is unavailable for pullout, a local bus may be substituted to ensure pullout. Operation of “branded” Metro Rapid buses is integral to the operating speed, simplicity of service, and customer experience.
Service Frequencies	Weekday peak frequency	The minimum weekday peak frequency should be 10 minutes or less.
	Weekday off-peak frequency	The preferred minimum weekday off-peak frequency is 20 minutes or less. Minimum frequency is subject to funding availability and may be relaxed to no more than 30 minutes. Service with headways wider than 20 minute should be re-evaluated and may warrant corrective action as the result.
Service Span	Service Span	Metro Rapid span of service should be from 5:00 a.m. to 9:00 p.m. on weekdays. Metro Rapid service should operate on weekends when warranted by passenger demand.

APPENDIX D: TYPICAL BUS STOP/ZONE DESIGN AND GUIDELINES

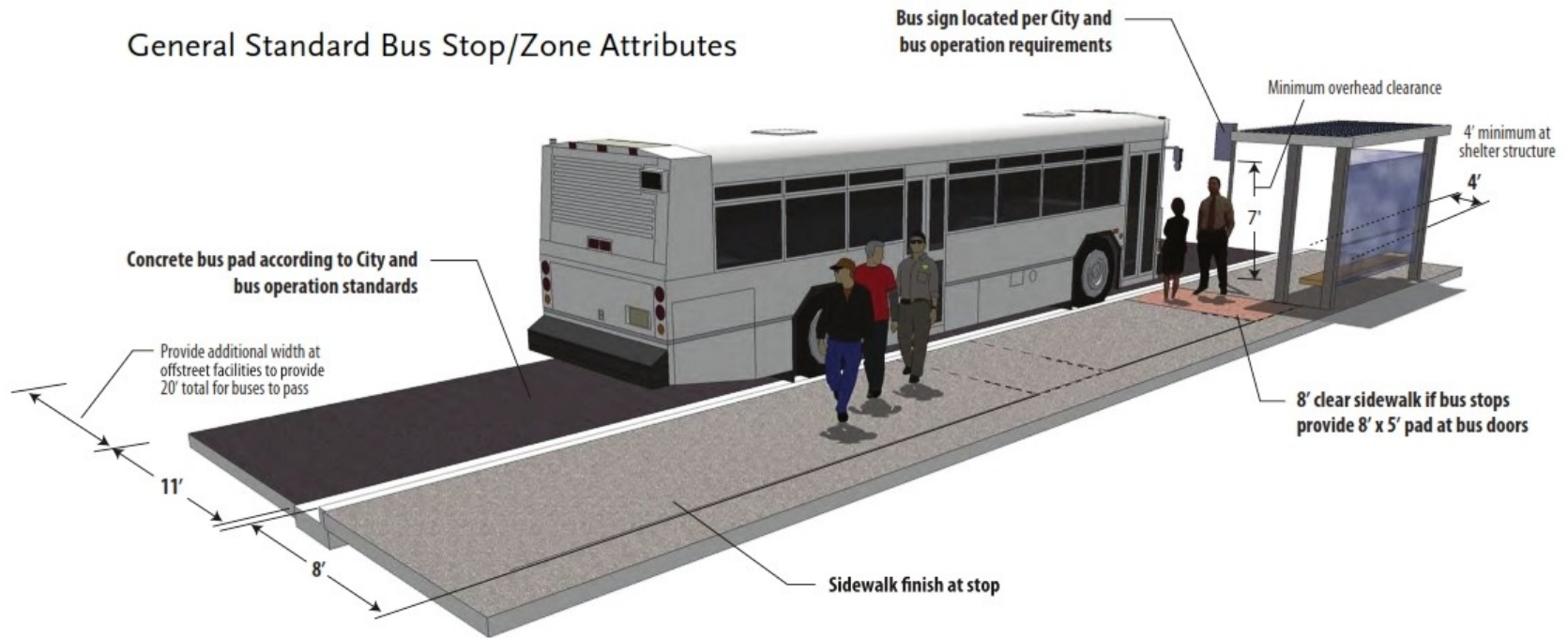

Note:
City of Los Angeles Requires its standard bus shelter to be 12-14 feet long, 4 1/2' wide, and 9 1/2' high



2016 Metro Transit Service Policies & Standards

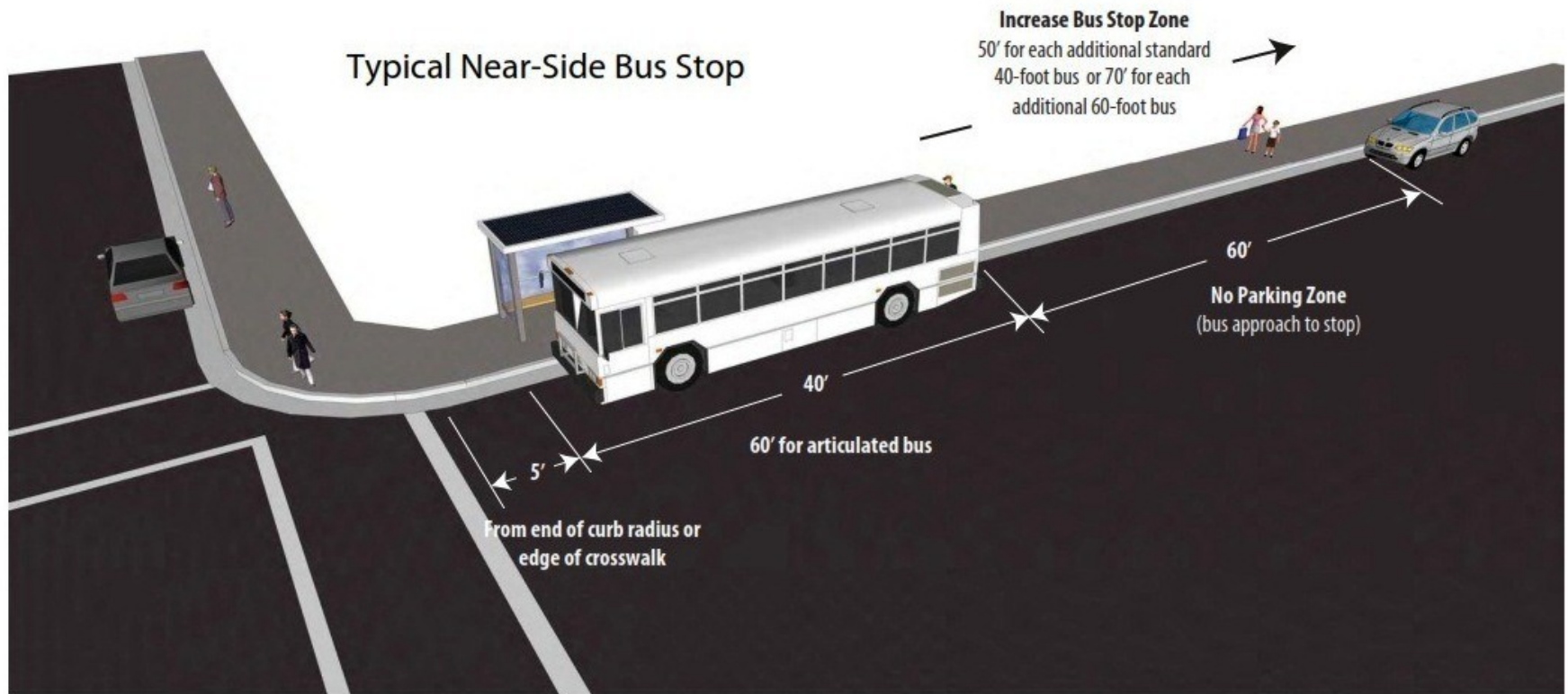

2016 Metro Transit Service Policies & Standards

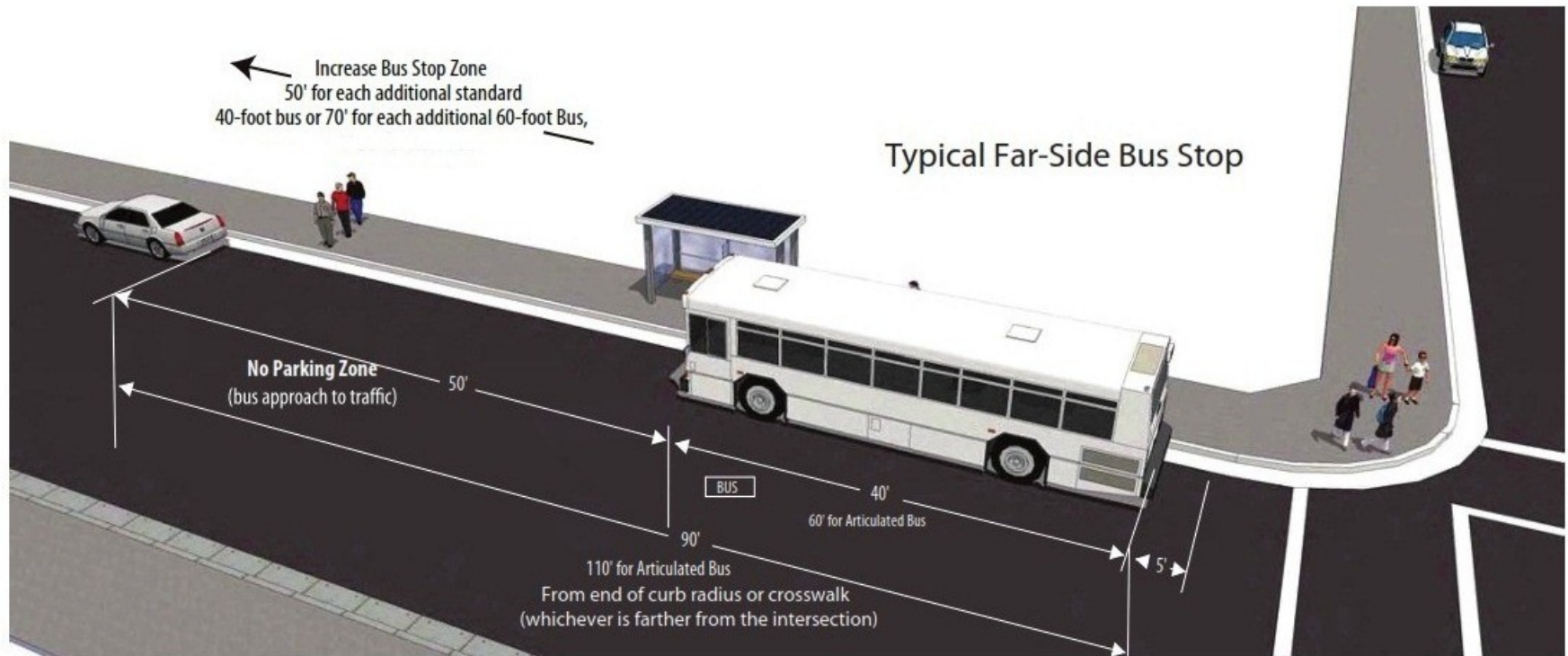

2016 Metro Transit Service Policies & Standards

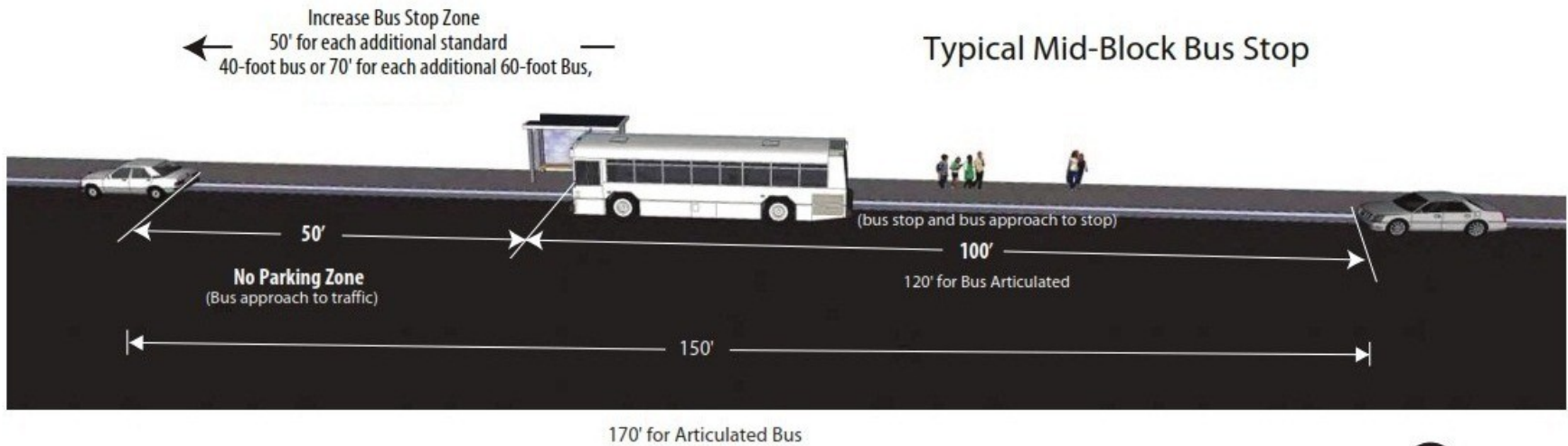

2016 Metro Transit Service Policies & Standards

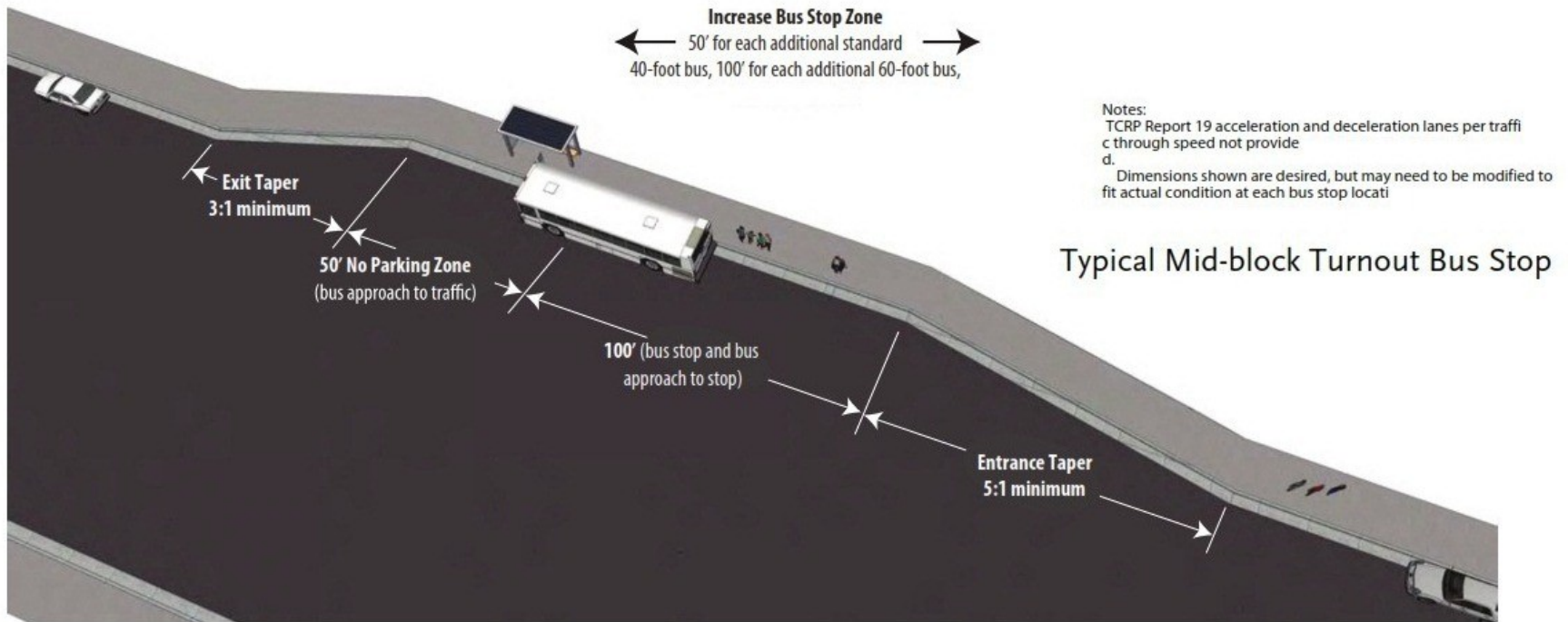

Note:
 Bus baywidth is desirably 12 feet, for traffic speeds under 30 mph, a 10 foot minimum baywidth is acceptable. These dimensions do not include the gutter width.



APPENDIX E: SCHOOL TRIPPER SERVICE CHANGE PROCEDURES

1. Service Development Managers (SDM) in the Service Planning & Scheduling Department are responsible for certifying that all school trippers in their respective service area fully comply with Metro's School Tripper Policy (Section 3.2-1). Each SDM will submit a report prior to each major service change program that details all existing and proposed school tripper service.
2. All regularly scheduled school trippers must be published on public timetables to ensure that both the general public, as well as the student population, are aware of the services.
3. School tripper "pink letters" require notification to the general public through the use of a service change notice or on Metro's webpage.
4. Uniform standards for the documentation of school tripper pink letters must be employed. This includes standardizing the pink letter form and oversight of the pink letter information being input into the SLS 2000 system to ensure accuracy. All requests for new school trippers and modifications to existing school trippers must be logged into the SLS2000 regardless if the requested new or modified school tripper is actually implemented.
5. Request for new school trippers or modifications to existing school trippers will be considered only if at least two weeks prior notice is provided to complete appropriate analysis of the request and to allow appropriate notification of changes to the general public.
6. SDMs are responsible for working with school districts in their service area which use school tripper service. For example, a specific protocol has been established with LAUSD in which their monthly Operations Coordinators' Meeting has a standing agenda item, "Metro Coordination," where special events and bell-time changes are disseminated to Metro through communication with staff and the meeting's minutes.

APPENDIX F: LOS ANGELES COUNTY LOCAL FIXED ROUTE TRANSIT OPERATORS

Operator	Municipal	Local Return
Agoura Hills		X
Alhambra		X
AVTA	X	X
Artesia		X
Avalon		X
Azusa		X
Baldwin Park		X
Beach Cities	X	X
Bell		X
Bell Gardens		X
Bellflower		X
Beverly Hills		X
Burbank		X
Calabasas		X
Carson		X
Cerritos		X
Commerce	X	X
Compton		X
Covina		X
Cudahy		X
Culver City	X	X
Downey		X
Duarte		X
El Monte		X
El Segundo		X
Foothill	X	X
Gardena	X	X
Glendale		X
Glendora		X
Hawthorne		X
Huntington Park		X
Inglewood		X
La Puente		X
Lawndale		X
Long Beach	X	X
Los Angeles	X	X
Los Angeles County		X
Lynwood		X
Manhattan Beach		X
Malibu		X
MAX		X
Maywood		X
Monrovia		X

2016 Metro Transit Service Policies & Standards

Operator	Municipal	Local Return
Montebello	X	X
Monterey Park		X
Norwalk	X	X
Palos Verdes Estates		X
Paramount		X
Pasadena		X
Pico Rivera		X
Pomona		X
Redondo Beach		X
Rosemead		X
San Fernando		X
SCVTA	X	X
Santa Fe Springs		X
Santa Monica	X	X
Sierra Madre		X
South Gate		X
Torrance	X	X
West Covina		X
West Hollywood		X
Westlake Village		X
Whittier		X
Total	13	63

APPENDIX G: SERVICE CHANGE PROCESS

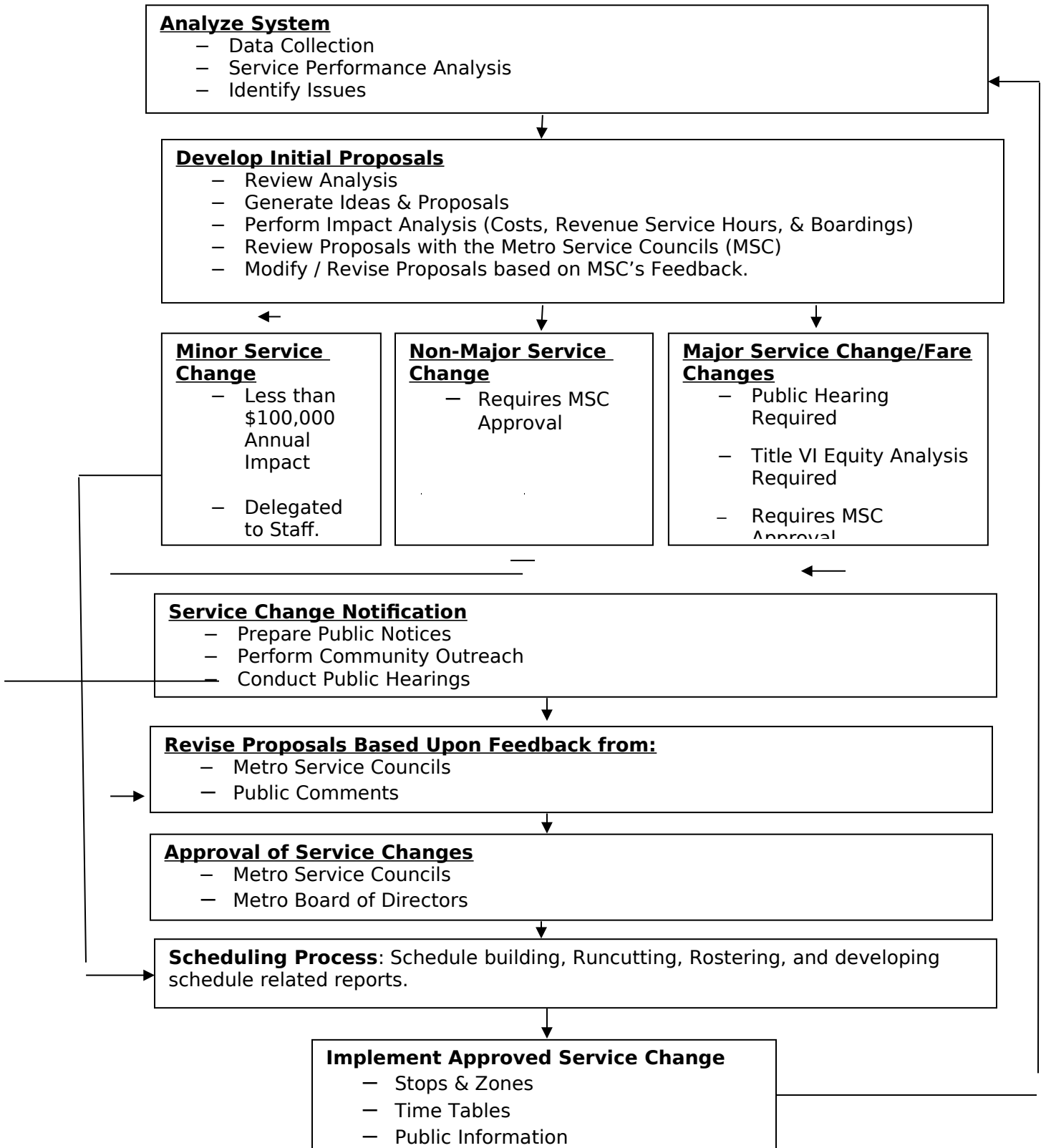

Transit Service Policy Update

Review of Policy Changes



Metro

Transit Service Policy

- What is the Transit Service Policy?
 - Key policy document that establishes:
 - A formal process for evaluating existing services
 - A methodology and process for developing and implementing service changes
 - Service design guidelines to provide high quality services to our customers and encourage ridership

Transit Service Policy

- 2012 was the Last Update
 - Adopt Revised Stop Spacing Standards
 - Change Load Factor to 1.3 x Seated Load
- 2015 Update
 - Timely
 - Opening two Rail Lines in Spring 2016
 - Assumption of no increase in the level of bus service hours
 - APTA Peer Review Recommendations (3/2015)



Transit Service Policy

- Basic Policy Changes
 - Increase load factor on our most frequent lines
 - Consolidate bus stops to increase speed
- Consider network of frequent services with focus on supporting core Bus & Rail lines
- Reallocate resources from poorer performers to higher productivity lines
- Improve coordination with Municipal Operators



Transit Service Policy

Load Factor

- **Current:** One standard: Peak / Off-Peak, weekends, and any service frequency
- **Proposed Standard**
 - Variable Standard considering:
 - Peak / Off-Peak
 - Bus Type
 - Service Frequency

Variable loading standards can produce efficiencies



Metro

Loading Standards by Bus Size

Weekday AM and PM Periods					Off Peaks and Weekends				
Bus Types					Bus Types				
Frequency Range in Minutes	Psgrs. / Seat	40 ft.	45 ft.	60 ft.	Frequency Range in Minutes	Psgrs. / Seat	40 ft.	45 ft.	60 ft.
		Average Peak Loads					Average Peak Loads		
1 - 10	1.40	56	65	80	1 - 10	1.30	52	60	74
11 -20	1.30	52	60	74	11 -20	1.25	50	58	71
21 - 40	1.20	48	55	68	21 - 40	1.10	44	51	63
41 -60	1.10	44	51	63	41 -60	1.00	40	46	57
60+	1.00	40	46	57	60+	0.75	30	35	43

Shaded area presents current load factor standard applicable at all times. This table replaces the all-day 130% standard with one that varies by peak/off-peak and schedule frequency.



Metro

Wait a longer time; get to sit down

Transit Service Policy

Stop Consolidation

- Metro has in excess of 15,000 bus stops
- Over past 5 years, bus speeds on average have declined (from 12 mph to less than 10.91 mph)
- As the system slows down, more resources needed to operate same headway
- Greater opportunity for accidents

Focus

- Reduce stops that are less than ¼ mile from each other
- Reduce stops that have little use
- Decrease running time and improve service efficiency
- Provide for smoother operation
- Improve safety

Transit Service Policy

- Operate 15-Minute Peak Service Network
 - Focus on Rail, BRT, Rapid, and other top performing lines
 - Follows grid pattern
 - One-half to 1-mile spacing of lines
 - Better quality & more reliable service on high-performing lines
 - Provides opportunities for other operators



Recommended 15-Minute Peak Network

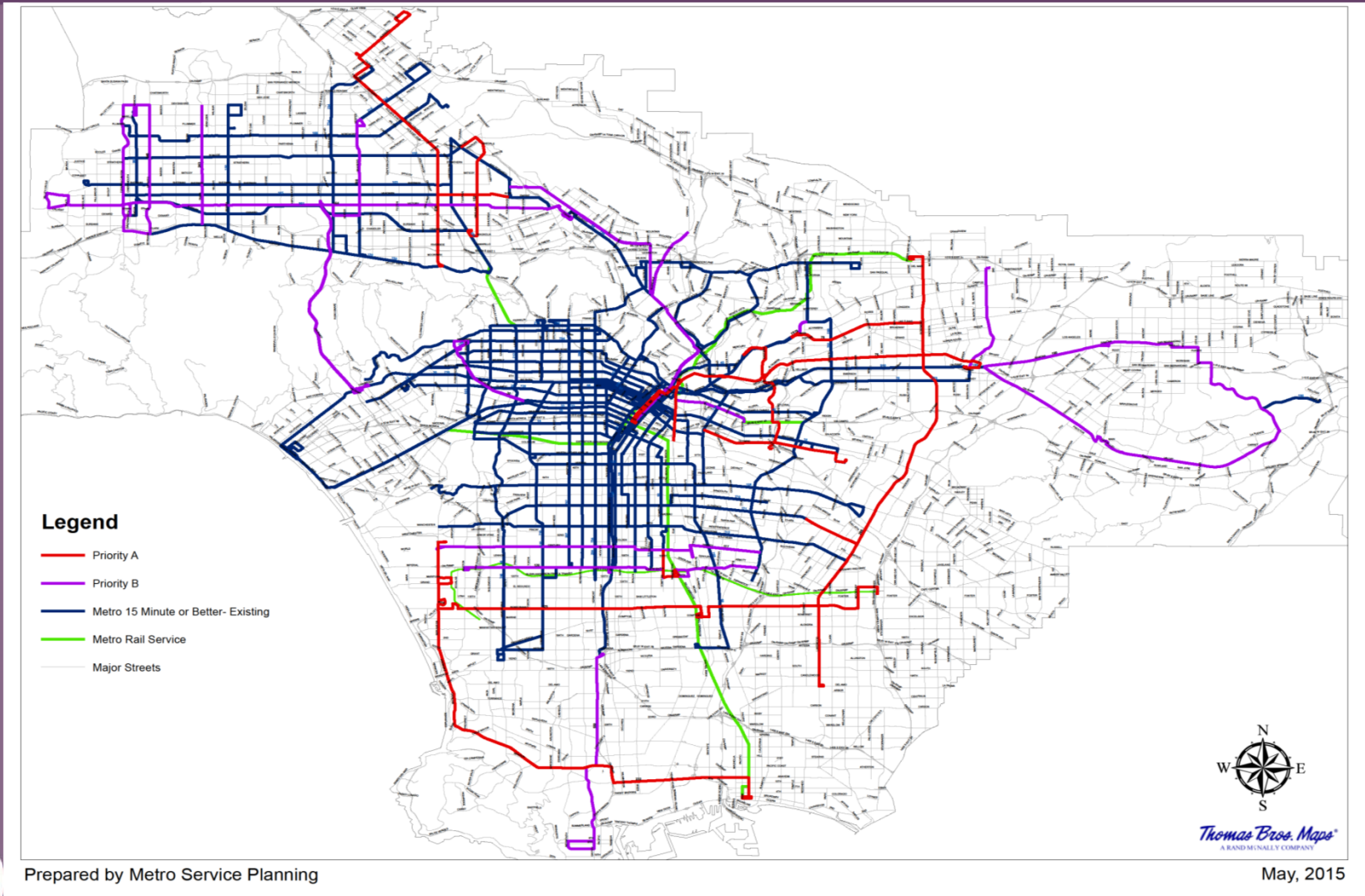

Prepared by Metro Service Planning

Metro

Metro-Municipal Operator

Transit corridors considered for future operation by another operator should:

- Add value to the customer through integration into an already established nearby transit operator;
- Complete another operator's route network;
- Improve connections to a municipal operator's established network;
- Generate net cost savings; Metro will calculate the FAP impacts for all service realignment proposals
- If Metro service is reduced, Metro should reinvest at least half of the net savings (operating cost less passenger revenue and FAP reduction) to improve service on Metro's core network of regionally significant bus lines.

Service Change Timeline

Key Activities	Required Lead Time (Months Prior to Implementation)
Initiate Planning Process	12
Develop Preliminary Recommendations	7-8
Impact Analysis for Proposed Changes	6-7
Title VI Equity Analysis on Major Service Change and Fare Change Proposals	5-7
Service Council Review and Input	6-7
Confer with Labor Relation and Union Representatives	5-6
Public Review and Input	5
Finalize Service Change Program	4-5
Program Approval	3-4
Develop New Service Schedules	2-4
Print Public Time Tables and Operator Assignments	1-2
Fabricate Decals for Bus Blades	1-2
Print Bus Cubes/Take-One Bus Inserts	1



Next Steps

- Initiate the Comprehensive Operations Analysis reviewing each line in the system
- Make recommendations for service changes:
 - Achieve the Peak 15 minute Frequent Service Network
 - Place more resources on core network services, e.g. Rapid Bus Lines
 - Right-size the owl service network
 - Provide opportunities for experimentation with point-to-point services



Project Timeline

- Complete service evaluations by November 2015, establish phasing plan & analyses
- Generate service changes for June 2016 by December 2015 (Service Councils set hearing dates)
- Hold Public Hearings in February 2016
- Adopt service change program March/April 2016
- Implement Plan Phase July 2016
- Evaluate changes by October 2016

Transit Service Policy Update

Questions?



Metro®