

Metro

*Los Angeles County Metropolitan Transportation Authority
One Gateway Plaza
3rd Floor Board Room*



Agenda - Final

Thursday, January 23, 2020

10:00 AM

**One Gateway Plaza, Los Angeles, CA 90012,
3rd Floor, Metro Board Room**

Board of Directors - Regular Board Meeting

*James Butts, Chair
Eric Garcetti, Vice Chair
Hilda Solis, 2nd Vice Chair
Kathryn Barger
Mike Bonin
Jacquelyn Dupont-Walker
John Fasana
Robert Garcia
Janice Hahn
Paul Krekorian
Sheila Kuehl
Ara Najarian
Mark Ridley-Thomas
John Bulinski, non-voting member*

Phillip A. Washington, Chief Executive Officer

METROPOLITAN TRANSPORTATION AUTHORITY BOARD RULES
(ALSO APPLIES TO BOARD COMMITTEES)

PUBLIC INPUT

A member of the public may address the Board on agenda items, before or during the Board or Committee's consideration of the item for one (1) minute per item, or at the discretion of the Chair. A request to address the Board must be submitted electronically using the tablets available in the Board Room lobby. Individuals requesting to speak will be allowed to speak for a total of three (3) minutes per meeting on agenda items in one minute increments per item. For individuals requiring translation service, time allowed will be doubled. The Board shall reserve the right to limit redundant or repetitive comment.

The public may also address the Board on non agenda items within the subject matter jurisdiction of the Board during the public comment period, which will be held at the beginning and/or end of each meeting. Each person will be allowed to speak for one (1) minute during this Public Comment period or at the discretion of the Chair. Speakers will be called according to the order in which their requests are submitted. Elected officials, not their staff or deputies, may be called out of order and prior to the Board's consideration of the relevant item.

Notwithstanding the foregoing, and in accordance with the Brown Act, this agenda does not provide an opportunity for members of the public to address the Board on any Consent Calendar agenda item that has already been considered by a Committee, composed exclusively of members of the Board, at a public meeting wherein all interested members of the public were afforded the opportunity to address the Committee on the item, before or during the Committee's consideration of the item, and which has not been substantially changed since the Committee heard the item.

In accordance with State Law (Brown Act), all matters to be acted on by the MTA Board must be posted at least 72 hours prior to the Board meeting. In case of emergency, or when a subject matter arises subsequent to the posting of the agenda, upon making certain findings, the Board may act on an item that is not on the posted agenda.

CONDUCT IN THE BOARD ROOM - The following rules pertain to conduct at Metropolitan Transportation Authority meetings:

REMOVAL FROM THE BOARD ROOM The Chair shall order removed from the Board Room any person who commits the following acts with respect to any meeting of the MTA Board:

- a. Disorderly behavior toward the Board or any member of the staff thereof, tending to interrupt the due and orderly course of said meeting.
- b. A breach of the peace, boisterous conduct or violent disturbance, tending to interrupt the due and orderly course of said meeting.
- c. Disobedience of any lawful order of the Chair, which shall include an order to be seated or to refrain from addressing the Board; and
- d. Any other unlawful interference with the due and orderly course of said meeting.

INFORMATION RELATING TO AGENDAS AND ACTIONS OF THE BOARD

Agendas for the Regular MTA Board meetings are prepared by the Board Secretary and are available prior to the meeting in the MTA Records Management Department and on the Internet. Every meeting of the MTA Board of Directors is recorded and is available at www.metro.net or on CD's and as MP3's for a nominal charge.

DISCLOSURE OF CONTRIBUTIONS

The State Political Reform Act (Government Code Section 84308) requires that a party to a proceeding before an agency involving a license, permit, or other entitlement for use, including all contracts (other than competitively bid, labor, or personal employment contracts), shall disclose on the record of the proceeding any contributions in an amount of more than \$250 made within the preceding 12 months by the party, or his or her agent, to any officer of the agency, additionally PUC Code Sec. 130051.20 requires that no member accept a contribution of over ten dollars (\$10) in value or amount from a construction company, engineering firm, consultant, legal firm, or any company, vendor, or business entity that has contracted with the authority in the preceding four years. Persons required to make this disclosure shall do so by filling out a "Disclosure of Contribution" form which is available at the LACMTA Board and Committee Meetings. Failure to comply with this requirement may result in the assessment of civil or criminal penalties.

ADA REQUIREMENTS

Upon request, sign language interpretation, materials in alternative formats and other accommodations are available to the public for MTA-sponsored meetings and events. All requests for reasonable accommodations must be made at least three working days (72 hours) in advance of the scheduled meeting date. Please telephone (213) 922-4600 between 8 a.m. and 5 p.m., Monday through Friday. Our TDD line is (800) 252-9040.

LIMITED ENGLISH PROFICIENCY

A Spanish language interpreter is available at all Committee and Board Meetings. All other languages must be requested 72 hours in advance of the meeting by calling (213) 922-4600 or (323) 466-3876.



323.466.3876 x2

Español

323.466.3876 x3

한국어

日本語

中文

русский

ភាសាខ្មែរ

ภาษาไทย

Tiếng Việt

ភាសាវៀតណាម

HELPFUL PHONE NUMBERS

Copies of Agendas/Record of Board Action/Recordings of Meetings - (213) 922-4880 (Records Management Department)

General Information/Rules of the Board - (213) 922-4600

Internet Access to Agendas - www.metro.net

TDD line (800) 252-9040

NOTE: ACTION MAY BE TAKEN ON ANY ITEM IDENTIFIED ON THE AGENDA

CALL TO ORDER

ROLL CALL

1. APPROVE Consent Calendar Items: 2, 7, 9, 10, 11, 13, 14, 15, 17, 20, 22, 25, 26, 27, 32, 33, 34, 35, 36, 38, 41, 42, 43, and 45

Consent Calendar items are approved by one motion unless held by a Director for discussion and/or separate action.

CONSENT CALENDAR

2. **SUBJECT: MINUTES** [2020-0006](#)

RECOMMENDATION

APPROVE Minutes of the Regular Board Meeting held December 5, 2019.

Attachments: [Regular Board Meeting MINUTES -December 5, 2019](#)

PLANNING AND PROGRAMMING COMMITTEE (5-0) AND EXECUTIVE MANAGEMENT COMMITTEE (6-0) MADE THE FOLLOWING RECOMMENDATION:

7. **SUBJECT: METRO AFFORDABLE HOUSING POLICIES AND TOOLS** [2019-0848](#)

RECOMMENDATION

- A. RECEIVE AND FILE Metro Affordable Housing Policies and Tools; and
- B. ADOPT the proposed amendments to the 2020 State Legislative Program Goals.

Attachments: [Attachment A - Summary of Completed and Pipeline Joint Development Portfolio Presentation](#)

**PLANNING AND PROGRAMMING COMMITTEE MADE THE FOLLOWING
RECOMMENDATION (4-0):**

- 9. SUBJECT: FUNDING AWARD RECOMMENDATION FOR FEDERAL
TRANSIT ADMINISTRATION SECTION 5310 GRANT
PROGRAM FUNDS**

[2019-0807](#)

RECOMMENDATION

CONSIDER:

- A. APPROVING the federal Section 5310 Enhanced Mobility for Seniors and Individuals with Disabilities Program (“Program”) recommended funding awards totaling up to \$9,926,791 for Traditional Capital and Other Capital Projects, as shown in Attachments A and B;
- B. AUTHORIZING the Chief Executive Officer (CEO) or his designee to (1) negotiate and execute pass-through agreements with the agencies approved for funding, and (2) apply \$194,400 of unused funds from past awards to the recommended funding awards;
- C. DELEGATING to the CEO or his designee the authority to administratively approve minor changes to the scope of previously-approved Section 5310 funding awards;
- D. CERTIFYING that the Section 5310 funds are fairly and equitably allocated to eligible sub-recipients and, where feasible, projects are coordinated with transportation services assisted by other federal agencies; and
- E. CERTIFYING that the projects proposed for Section 5310 funding are included in the locally-developed 2016-2019 Coordinated Public Transit-Human Services Transportation Plan for Los Angeles County (“Coordinated Plan”) that was developed and approved through a process that included participation by seniors and individuals with disabilities, as well as by representatives of public, private and nonprofit transportation and human service providers and other members of the public.

Attachments: [Attachment A - Los Angeles Long Beach Anaheim Urbanized Areas](#)
[Attachment B - Lancaster Palmdale Urbanized Areas](#)
[Attachment C - Evaluation Criteria](#)

PLANNING AND PROGRAMMING COMMITTEE MADE THE FOLLOWING RECOMMENDATION (4-0):

- 10. SUBJECT: METRO ACTIVE TRANSPORT, TRANSIT AND FIRST/LAST MILE (MAT) PROGRAM CYCLE 1** [2019-0834](#)

RECOMMENDATION

CONSIDER:

- A. APPROVING the Metro Active Transport, Transit, and First/Last Mile (MAT) Program Cycle 1 Solicitation; and
- B. AUTHORIZING the Chief Executive Officer (CEO) or designee to release the Program Solicitation and initiate a project selection process as described therein.

Attachments: [Attachment A - MAT Program Cycle One Solicitation](#)
[Attachment B - MAT Program Administrative Procedures](#)
[Attachment C - Metro Board Motion 14.1](#)
[Presentation](#)

PLANNING AND PROGRAMMING COMMITTEE MADE THE FOLLOWING RECOMMENDATION (4-0):

- 11. SUBJECT: MEASURE R HIGHWAY SUBREGIONAL PROGRAM SEMI-ANNUAL UPDATE** [2019-0838](#)

RECOMMENDATION

CONSIDER:

- A. APPROVING \$109,537,000 of additional programming within the capacity of the Measure R Highway Subregional Programs and funding changes via the updated project list as shown in Attachment A for:
 - Highway Operational Improvements in Arroyo Verdugo
 - Highway Operational Improvement in Las Virgenes Malibu
 - I-405, I-110, I-105 and SR-91 Ramp and Interchange Improvements (South Bay)
 - I-605 Corridor "Hot Spots" Interchange Improvements in Gateway Cities
 - I-710 South and/or Early Action Projects in Gateway Cities
- B. APPROVING deobligation of \$1,390,000 dollars of previously approved Measure R Highway Subregional Program funds for re-allocation at the request of project sponsors;

-
- C. AUTHORIZING the CEO or his designee to negotiate and execute all necessary agreements for the approved projects.

Attachments: [Attachment A - Projects Receiving Measure R Funds](#)

PLANNING AND PROGRAMMING COMMITTEE MADE THE FOLLOWING RECOMMENDATION (4-0):

13. SUBJECT: GREEN LINE EXTENSION TO TORRANCE

[2019-0823](#)

RECOMMENDATION

AUTHORIZE the Chief Executive Officer (CEO) to award and execute a 42-month, firm fixed price Contract No. AE63445000 with STV Incorporated (STV), in the amount of \$32,555,439 to provide environmental, advanced conceptual engineering (ACE) design, and optional preliminary engineering (PE) services on the Green Line Extension to Torrance Project for work in support of the environmental clearance study and design services, subject to resolution of protest(s), if any.

Attachments: [Attachment A - Procurement Summary](#)
[Attachment B - DEOD Summary](#)
[Attachment C - Project Study Area Map](#)
[Presentation](#)

PLANNING AND PROGRAMMING COMMITTEE MADE THE FOLLOWING RECOMMENDATION (4-0):

14. SUBJECT: PURPLE LINE EXTENSION SECTION 1, CRENSHAW/LAX AND REGIONAL CONNECTOR FIRST/LAST MILE PLANNING

[2019-0806](#)

RECOMMENDATION

AUTHORIZE the Chief Executive Officer (CEO) to:

- A. Prepare First/Last Mile (FLM) plans for Purple Line Extension (PLE) Section 1 stations;
- B. Execute Modification No. 3 to Task Order No. AE115994000 with IBI Group for the Purple Line Sections 2 and 3 First/Last Mile (FLM) Plan and Guidelines to accommodate PLE Section 1 FLM planning work in the amount of \$378,864 increasing the task order value from \$1,171,722 to \$1,550,586; and
- C. Subsequently initiate planning for stations on the Crenshaw/LAX line and Regional Connector.

-
- Attachments:** [Attachment A - Procurement Summary](#)
[Attachment B - Task Order Modification Change Order Log](#)
[Attachment C - DEOD Summary](#)

PLANNING AND PROGRAMMING COMMITTEE MADE THE FOLLOWING RECOMMENDATION (4-0):

- 15. SUBJECT: ALAMEDA CORRIDOR-EAST (ACE) PROGRAM FUNDING PLAN UPDATE** [2019-0850](#)

RECOMMENDATION

AUTHORIZE the CEO to amend the ACE funding agreement to increase Metro's contribution by \$15,000,000 (5.5% increase to the 2007 amount of \$274,323,220) for a new total amount of \$289,323,220 and program \$19,453,420, which includes previously committed funding. Metro will not participate in any future project cost increases or overruns.

- Attachments:** [Attachment A - ACE Program Revised Cost and Funding Request](#)
[Attachment B - SGVCOG Letter of Request](#)
[Attachment C - Measure R and Measure M Unified Cost Management Policy An Presentation](#)

FINANCE, BUDGET AND AUDIT COMMITTEE MADE THE FOLLOWING RECOMMENDATION (3-0-1):

- 17. SUBJECT: RISK MANAGEMENT INSURANCE BROKERAGE SERVICES** [2019-0795](#)

RECOMMENDATION

AUTHORIZE the Chief Executive Officer to award a five-year, firm fixed price Contract No. PS63853000 to USI Insurance Services LLC in the amount of \$1,268,600 for a five-year base term, \$530,503 for the first 2-year option, and \$562,811 for the second 2-year option, for a combined total amount of \$2,361,914, effective June 1, 2020 subject to resolution of protest(s), if any.

- Attachments:** [Attachment A - Procurement Summary](#)
[Attachment B - DEOD Summary](#)

OPERATIONS, SAFETY AND CUSTOMER EXPERIENCE COMMITTEE MADE THE FOLLOWING RECOMMENDATION (3-0):

- 20. SUBJECT: MEMBERSHIP ON METRO'S REGIONAL SERVICE COUNCILS** [2019-0802](#)

RECOMMENDATION

APPROVE nominees for membership on Metro's San Gabriel Valley and Westside Central Service Councils.

Attachments: [Attachment A - Nominees Listing of Qualifications](#)
[Attachment B - Nomination Letters](#)
[Presentation](#)

OPERATIONS, SAFETY AND CUSTOMER EXPERIENCE COMMITTEE MADE THE FOLLOWING RECOMMENDATION (3-0):

- 22. SUBJECT: P2000 LIGHT RAIL VEHICLE (LRV) POWERED AXLE ASSEMBLY OVERHAUL** [2019-0861](#)

RECOMMENDATION

AUTHORIZE the Chief Executive Officer to award a 60-month, Indefinite Delivery/Indefinite Quantity (IDIQ) Contract No. MA53169000 to Pamco Machine Works, the lowest responsive and responsible bidder, for the overhaul of P2000 Light Rail Vehicle (LRV) Powered Axle Assembly Overhaul. This award is a not-to-exceed amount of \$3,132,902 subject to resolution of protest(s), if any.

Attachments: [Attachment A - Procurement Summary](#)
[Attachment B - DEOD Summary](#)

OPERATIONS, SAFETY AND CUSTOMER EXPERIENCE COMMITTEE MADE THE FOLLOWING RECOMMENDATION (3-0):

- 25. SUBJECT: ENTERPRISE SAFETY MANAGEMENT SYSTEM** [2019-0816](#)

RECOMMENDATION

AUTHORIZE the Chief Executive Officer to execute Modification No. 3 to Contract No. PS43249000 with Cority Software Inc. to add the Environmental and Ergonomics modules to the Enterprise Safety Management System (ESMS) in the amount of \$594,980, increasing the total contract value from \$1,292,926 to \$1,887,906 and extending the contract period of performance through December 31, 2020.

-
- Attachments:** [Attachment A - Procurement Summary](#)
 [Attachment B - Contract Modification Change Order Log](#)
 [Attachment C - DEOD Summary](#)

OPERATIONS, SAFETY AND CUSTOMER EXPERIENCE COMMITTEE MADE THE FOLLOWING RECOMMENDATION (3-0):

26. SUBJECT: I-10 EXPRESSLANES BUSWAY HOV5+ PILOT IMPLEMENTATION PLAN [2019-0658](#)

RECOMMENDATION

CONSIDER:

- A. APPROVING I-10 ExpressLanes Busway HOV5+ Pilot Implementation Plan; and
- B. AUTHORIZING implementation of the I-10 ExpressLanes Busway HOV5+ Pilot.

- Attachments:** [Attachment A - April 26, 2018 Board Motion 43](#)
 [Attachment B - Draft I-10 Pilot Implementation Plan Executive Summary](#)
 [Attachment C - Draft I-10 Pilot ExpressLanes/Busway Pilot Implementation Plan](#)

OPERATIONS, SAFETY AND CUSTOMER EXPERIENCE COMMITTEE MADE THE FOLLOWING RECOMMENDATION (3-0):

27. SUBJECT: REAL ESTATE MANAGEMENT SYSTEM [2019-0870](#)

RECOMMENDATION

AUTHORIZE the Chief Executive Officer to award a six-year firm-fixed price Contract No. PS62371000 to Flairsoft Ltd. for the purchase of Real Estate Management System and software support services in the amount of \$946,463, plus optional licenses, modules and subscription maintenance and support of \$714,960 for a combined total amount of \$1,661,423, subject to resolution of protest(s), if any.

- Attachments:** [Attachment A - Procurement Summary.pdf](#)
 [Attachment B - DEOD Summary.pdf](#)
 [Presentation](#)

CONSTRUCTION COMMITTEE MADE THE FOLLOWING RECOMMENDATION (3-0):

- 32. SUBJECT: I-5 NORTH CAPACITY ENHANCEMENTS FROM SR- 118
TO SR-134; SEGMENT 3**

[2019-0829](#)

RECOMMENDATION

AUTHORIZE Contract Modification No. 235 (CCO 235) by the California Department of Transportation (Caltrans) for the construction contract for Segment 3 (Empire) of I-5 North Capacity Enhancements Project between SR-134 and SR-118 (Project) in the amount not to exceed \$1.5 M under Funding Agreement No. MOU. P0008355/8501A/A9 within the LOP budget.

CONSTRUCTION COMMITTEE MADE THE FOLLOWING RECOMMENDATION (3-0):

- 33. SUBJECT: CONSTRUCTION ZONE ENHANCED ENFORCEMENT
PROGRAM (COZEEP) SERVICES**

[2019-0844](#)

RECOMMENDATION

AUTHORIZE the Chief Executive Officer (CEO) to:

- A. Enter into an Interagency Agreement with California Highway Patrol (CHP) for Construction Zone Enhanced Enforcement Program (COZEEP) task order services for an amount of \$6,000,000; and
- B. Execute all necessary changes and task orders required to administer the agreement.

CONSTRUCTION COMMITTEE MADE THE FOLLOWING RECOMMENDATION (4-0):

- 34. SUBJECT: ENVIRONMENTAL CONSTRUCTION WASTE HANDLING
SERVICES**

[2019-0885](#)

RECOMMENDATION

AUTHORIZE:

- A. An increase to the total authorized funding for Contract No. PS20655 with TRC Solutions Inc. to increase Environmental Construction and Waste Handling Services contract value in the amount of \$20,600,000, increasing the Total Contract Value from \$46,200,000 to \$66,800,000, and
- B. The Chief Executive Officer (CEO) to execute all individual Task Orders and changes within the new Board approved contract funding amount.

CONSTRUCTION COMMITTEE MADE THE FOLLOWING RECOMMENDATION (4-0):

35. SUBJECT: SUSTAINABILITY PROGRAM ASSISTANCE SERVICES [2019-0887](#)

RECOMMENDATION

AUTHORIZE:

- A. An increase to the total authorized funding for Contract No. PS325890084203243 with Cumming Construction Management, Inc. to provide Sustainability Program Assistance Services (SPAS) support in the amount of \$1,548,036 increasing the Total Contract Value from \$13,729,353 to \$15,277,389; and
- B. The Chief Executive Officer (CEO) to execute all individual Task Orders and changes within the new Board approved contract funding amount.

CONSTRUCTION COMMITTEE MADE THE FOLLOWING RECOMMENDATION (3-0):

36. SUBJECT: ENVIRONMENTAL ENGINEERING SERVICES [2019-0888](#)

RECOMMENDATION

AUTHORIZE

- A. An increase to the total authorized funding for Contract No. PS3274 with Kleinfelder, Inc. to provide Environmental Engineering support services in the amount of \$11,926,155 increasing the Total Contract Value (CMA) from \$13,200,000 to \$25,126,155, and
- B. The Chief Executive Officer (CEO) to execute all individual Task Orders and changes within the Board approved contract funding amount.

EXECUTIVE MANAGEMENT COMMITTEE MADE THE FOLLOWING RECOMMENDATION (4-0):

38. SUBJECT: STATE LEGISLATION [2020-0021](#)

RECOMMENDATION

ADOPT staff recommended positions:

- A. ~~Senate Bill 732 (Allen) — Transactions and use tax: South Coast Air Quality Management District.~~ **SUPPORT**
- B. Assembly Bill 1350 (Gonzalez) - Free youth transit passes: eligibility for state funding. **WORK WITH AUTHOR**

43. SUBJECT: ESTABLISH K-12 U-PASS PRICING AND CONTINUE REGIONAL U-PASS PROGRAM

[2019-0879](#)

RECOMMENDATION

APPROVE

1. The establishment of a K-12 pricing structure for the Universal Student Pass (U-Pass) Program for homeless student services programs at \$0.75 per boarding to match the college program, capped at \$24 per month for Metro boardings to match the existing K-12 Reduced Fare monthly pass.
2. The continuation of the Regional U-Pass Program for College/Vocational schools at the existing rate, which is each agency's college fare rate, up to \$0.75 per Boarding, capped at \$43 per month to match the College/Vocational Reduced Fare monthly pass.
3. The establishment of a Regional K-12 pricing structure for homeless student services programs, which is each agency's K-12 fare up to \$0.75 per boarding, capped at the highest monthly K-12 fare rate of all agencies used by the institution's students or \$40 per month, which is the highest monthly K-12 fare in the region, if no K-12 monthly fare exists at those agencies

Attachments: [Attachment A - File #:2016-0333, Board Report on Approve Adoption of Univers Presentation U-Pass K-12](#)

EXECUTIVE MANAGEMENT COMMITTEE MADE THE FOLLOWING RECOMMENDATION (6-0):

45. SUBJECT: BRIDGE HOUSING AT VAN NUYS STATION

[2020-0045](#)

RECOMMENDATION

Direct the Chief Executive Officer (CEO) to:

- A. Enter into a no-fee lease agreement with the City of Los Angeles (COLA) with a term ending August 15, 2023 for temporary bridge housing on a portion of the Van Nuys Orange Line Station parking lot;
- B. Re-inventory Metro-owned properties to identify other opportunities for the City of Los Angeles's A Bridge Home Program (ABH) facilities and report back to the March 2020 Executive Management Committee;
- C. Conclude the project is statutorily exempt from CEQA pursuant to Public Resources Code Sections 21080.27 and 21080, Subdivision (b)(4), and

CEQA Guidelines Section 15269, Subdivision (c); and

D. Authorize Metro staff to file a Notice of Exemption with the County Clerk.

Attachments: [Attachment A - MOL Improvements](#)

NON-CONSENT

3. SUBJECT: REMARKS BY THE CHAIR [2020-0071](#)

RECOMMENDATION

RECEIVE remarks by the **Chair**.

4. SUBJECT: REPORT BY THE CHIEF EXECUTIVE OFFICER [2020-0072](#)

RECOMMENDATION

RECEIVE report by the **Chief Executive Officer**.

PLANNING AND PROGRAMMING COMMITTEE RECOMMENDED APPROVAL OF THE FOLLOWING HAHN, SOLIS, BUTTS MOTION (4-0):

8.1. SUBJECT: LOS ANGELES COUNTY GOODS MOVEMENT STRATEGIC PLAN DEVELOPMENT STATUS UPDATE [2020-0067](#)

RECOMMENDATION

APPROVE Motion by Directors Hahn, Solis, Butts, Garcia and Najarian that the Board:

1. Direct that the I-710 Clean Truck Program be developed as an Early Action Item under both the Goods Movement Strategic Plan as well as the I-710 South Corridor Project.
2. Request a report back in 60 days that provides a framework for implementation of the 710 Clean Truck Program. This framework should delineate, at a minimum the:
 - a. Assessment of eligible Metro funding sources and recommendations for seed funding.
 - b. Development of implementation details, including eligibility requirements, institutional arrangements, management, staff resources and administration.
 - c. Evaluation of different potential strategies to accelerate progressive transition to Zero Emission Trucks in the I-710 corridor.

d. Recommendations on how to encourage the participation of key regulatory agencies and stakeholders in the development of the program, with a specific focus on community-based organizations, non-profits, and community advocacy groups.

PLANNING AND PROGRAMMING COMMITTEE AND EXECUTIVE MANAGEMENT COMMITTEE FORWARDED THE FOLLOWING WITHOUT RECOMMENDATION:

12. SUBJECT: MOBILITY ON DEMAND PILOT PROJECT

[2019-0833](#)

RECOMMENDATION

AUTHORIZE the Chief Executive Officer to execute a Modification to Contract No. PS121778000 to exercise a six-month extension to the existing contract with NoMad Transit LLC, to continue to operate the Mobility on Demand (“MOD”) pilot project with enhanced service design for additional research at an increase in contract value not to exceed ~~\$1,530,332~~ \$2,180,332, increasing the contract value from \$2,506,410 to ~~\$4,036,742~~ \$4,686,742, and, at the discretion of the Chief Executive Officer, add an additional six months of service for a not to exceed amount of ~~\$2,097,293~~ \$2,747,293, increasing the contract from ~~\$4,036,742~~ \$4,686,742 to up to ~~\$6,134,035~~ \$7,434,035, with no further options to extend.

- Attachments:**
- [Attachment A - Third Quarter Report](#)
 - [Attachment B - Preliminary Research Findings](#)
 - [Attachment C - Service Areas](#)
 - [Attachment D - Procurement Summary](#)
 - [Attachment E - Modification Log](#)

PLANNING AND PROGRAMMING COMMITTEE AND EXECUTIVE MANAGEMENT COMMITTEE FORWARDED THE FOLLOWING WITHOUT RECOMMENDATION:

12.1. SUBJECT: MOBILITY ON DEMAND PILOT PROJECT

[2020-0043](#)

RECOMMENDATION

APPROVE Najarian motion that staff conduct an analysis of the mobility on demand pilot program that includes, but is not limited to, the following:

- A. Drivers’ fully-burdened salaries; MTA staffing and budgetary costs associated with the program; fully burdened cost per trip; compliance with Federal funding requirements; extrapolation of potential future cost increases due to AB5, and any other costs/charges.
- B. The completed analysis should return to the Board in May 2020.

**OPERATIONS, SAFETY AND CUSTOMER EXPERIENCE COMMITTEE MADE THE
FOLLOWING RECOMMENDATION AS AMENDED:**

- 21. SUBJECT: PUBLIC REVIEW OF NEXTGEN TRANSIT FIRST SERVICE
PLAN**

[2019-0853](#)

RECOMMENDATION

CONSIDER:

1. AUTHORIZING the release of the NextGen Draft Transit First Service Plan for public review; and
2. APPROVING updates to the Transit Service Policy to reflect the NextGen Regional Service Concept

BONIN AMENDMENT: Add a report back from OMB by April 2020 regarding funding options for the capital portion of the NextGen Transit First scenario.

Attachments: [Attachment A - NextGen Transit First Service Plan](#)
 [Attachment B - Transit Service Policy](#)
 [Presentation](#)

- 46. SUBJECT: FREE TRANSIT FOR LOS ANGELES COUNTY STUDENTS**

[2020-0077](#)

RECOMMENDATION

APPROVE Motion by Directors Solis, Garcetti, Bonin, Dupont-Walker, Butts and Hahn that the Board direct the CEO in collaboration with LAUSD and other school districts, local municipalities, the State and other stakeholders, to return to the Board in April 2020 with a report that includes:

1. Review of the performance of existing free transit programs for K-12 students, including the City of Los Angeles' DASH to Class program, Metro's Just Transit pilot with LAUSD and other school districts, and the City of Sacramento's RydeFreeRT program;
2. Cost estimates for the provision of free Metro transit services for LAUSD and other school district students and potential funding mechanisms to offset those costs with considerations for phasing based on Metro's Equity Platform; Cost estimates should include information on fare subsidies and costs to administer the program;
3. Forecasts of impacts to Metro farebox revenues as a result of free Metro transit services based on existing K-12 student pass utilization and other data;

4. A survey of various schools, in collaboration with LAUSD and other school districts, to determine transit dependency and interest of students switching to transit as a result of potential free fares;
5. Mapping of various school district boundaries in the County in relation to existing and planned transit services utilizing Metro's Equity Platform to identify high-need communities;
6. Analysis of effects on ridership, inclusive of impacts to operations on transit lines that may experience over-crowding during peak hours and potential impacts to school bus ridership;
7. Outreach to municipal operators that have transit service supported by Metro formula funds connecting to K-12 schools;
8. Recommended actions to minimize or eliminate barriers for Los Angeles County households to take advantage of potential free transit for students, including, but not limited to, partnering with LAUSD and other school districts for administrative support;
9. Return to the Board in June 2020 with a separate report, covering directives 1 through 8 of motion 46, on a partnership with Community College Districts within Metro's service area to provide no-cost transit programs for campuses that have self-imposed supplemental student fees dedicated towards the cost of transportation, including but not limited to the LA Community College District (LACCD) and LACCD's College Promise program.

47. SUBJECT: CLOSED SESSION

[2020-0074](#)

RECOMMENDATION

CONSIDER approval of:

A. Public Employee Performance Evaluation - G.C. 54957(b)(1)

Titles: Chief Executive Officer, General Counsel, Board Secretary, Inspector General, and Chief Ethics Officer.

B. Conference with Legal Counsel - Existing Litigation - G.C. 54956.9(d)(1)

1. City of Beverly Hills v. LACMTA, USDC Case No. CV-18-3891 -GW(SSx)
2. LACMTA v. Beverly Hills Unified School District, et al., Case No. 19STCV18197
3. John Reddick v. LACMTA, Case No. BC 660135
4. Kanasha Renee Sanders v. LACMTA, et al., Case No. BC 662414

5. Judy Solis v. LACMTA, Case No. BC 699379
6. Margaret Strowski v. LACMTA, Case No. BC 695559
7. Jonathan Aguilar v. LACMTA, Case No. BC 681858

C. Conference with Legal Counsel - Anticipated Litigation - G.C. 54956.9(d)
(2)

Significant Exposure to Litigation (Two Cases)

D. Conference with Real Estate Negotiator - G.C. 54956.8

1. Property Description: 9601 Aviation Boulevard, Los Angeles, CA
90045

Agency Negotiator: Craig Justesen
Negotiating Party: Clean Energy
Under Negotiation: Price and terms

SUBJECT: GENERAL PUBLIC COMMENT

[2020-0073](#)

RECEIVE General Public Comment

Consideration of items not on the posted agenda, including: items to be presented and (if requested) referred to staff; items to be placed on the agenda for action at a future meeting of the Committee or Board; and/or items requiring immediate action because of an emergency situation or where the need to take immediate action came to the attention of the Committee subsequent to the posting of the agenda.

COMMENTS FROM THE PUBLIC ON ITEMS OF PUBLIC INTEREST WITHIN COMMITTEE'S
SUBJECT MATTER JURISDICTION

Adjournment



Board Report

File #: 2020-0006, **File Type:** Minutes

Agenda Number: 2.

**REGULAR BOARD MEETING
JANUARY 23, 2020**

SUBJECT: MINUTES

RECOMMENDATION

APPROVE Minutes of the Regular Board Meeting held December 5, 2019.



MINUTES

Thursday, December 5, 2019

10:00 AM

**One Gateway Plaza, Los Angeles, CA 90012,
3rd Floor, Metro Board Room**

Board of Directors - Regular Board Meeting

DIRECTORS PRESENT:

**James Butts, Chair
Hilda Solis, 2nd Vice Chair
Kathryn Barger
Mike Bonin
John Fasana
Robert Garcia
Janice Hahn
Paul Krekorian
Sheila Kuehl
Ara Najarian**

Mark Archuleta, non-voting member

Phillip A. Washington, Chief Executive Officer

CALLED TO ORDER AT: 10:25 A.M.

ROLL CALL

1. APPROVED Consent Calendar Items: 2, 9, 10, 13, 14, 16, 18, 24, 25, 26, 27, 31, 35, 36, and 37

Consent Calendar items were approved by one motion except for Item 27 which was held by a Director for discussion and separate action.

JF	PK	MB	RG	SK	EG	JB	HS	JH	KB	JDW	MRT	AN
Y	Y	Y	Y	Y	A	Y	Y	Y	Y	A	A	Y

2. **SUBJECT: MINUTES** **2019-0800**

APPROVED ON CONSENT CALENDAR Minutes of the Regular Board Meeting held October 24, 2019.

3. **SUBJECT: REMARKS BY THE CHAIR** **2019-0857**

RECEIVED remarks by the Chair.

JF	PK	MB	RG	SK	EG	JB	HS	JH	KB	JDW	MRT	AN
P	P	P	P	P	A	P	P	P	P	A	A	P

4. **SUBJECT: REPORT BY THE CHIEF EXECUTIVE OFFICER** **2019-0858**

RECEIVED report by the Chief Executive Officer.

JF	PK	MB	RG	SK	EG	JB	HS	JH	KB	JDW	MRT	AN
P	P	P	P	P	A	P	P	P	P	A	A	P

PK = P. Krekorian	HS = H. Solis	KB = K. Barger	RG = R. Garcia
JF = J. Fasana	JB = J. Butts	JDW = J. Dupont-Walker	
JH = J. Hahn	EG = E. Garcetti	MRT = M. Ridley-Thomas	
MB = M. Bonin	SK = S. Kuehl	AN = A. Najarian	

LEGEND: Y = YES, N = NO, C = HARD CONFLICT, S = SOFT CONFLICT ABS = ABSTAIN, A = ABSENT, P = PRESENT

7. SUBJECT: MEASURE R ORDINANCE PRELIMINARY 10-YEAR REVIEW AND POTENTIAL AMENDMENTS

2019-0629

RECEIVED AND FILED the Measure R Ordinance Preliminary Ten-Year Review AS AMENDED by the following motions:

Motion by Directors Butts, Hahn, Solis, Barger and Dupont-Walker:

Instruct Staff to provide monthly progress reports on the development of a process to implement a "Transfer" Amendment to the Measure R Ordinance.

The first report should be brought forward in the January Board cycle and should include preliminary recommendations for Metro staff to develop a detailed process that identifies the steps and responsibilities.

Motion by Director Bonin:

Instruct staff to include in this process updating the Measure R Ordinance to reflect current Board policies, including relevant sustainability and complete streets policies.

JF	PK	MB	RG	SK	EG	JB	HS	JH	KB	JDW	MRT	AN
Y	Y	Y	Y	Y	A	Y	Y	Y	Y	A	A	Y

9. SUBJECT: LONE HILL TO WHITE DOUBLE TRACK

2019-0519

APPROVED ON CONSENT CALENDAR:

- A. the programming of \$7.5 million in Measure R 3% commuter rail funds for final design including third party costs of the Lone Hill to White (LHW) Double Track Project; and
- B. AUTHORIZED the Chief Executive Officer to negotiate and execute all agreements for the LHW final design.

10. SUBJECT: THIRD PARTY REQUEST FOR DEVIATIONS FROM SYSTEMWIDE STATION DESIGN STANDARDS POLICY

2019-0618

APPROVED ON CONSENT CALENDAR Third Party Request for Design Deviation from Systemwide Station Design Standards.

11. SUBJECT: EXPO/CRENSHAW JOINT DEVELOPMENT

2019-0624

AUTHORIZED the Chief Executive Officer to execute an amendment to the Exclusive Negotiation Agreement and Planning Document with Watt Companies, doing business as WIP-A, LLC, and the County of Los Angeles for 12 months with the option to extend for an additional four months for the joint development of 1.77 acres of Metro-owned property and 1.66 acres of County-owned property at the Expo/Crenshaw Station.

JF	PK	MB	RG	SK	EG	JB	HS	JH	KB	JDW	MRT	AN
Y	Y	C	A	Y	A	Y	Y	Y	C	A	A	Y

13. SUBJECT: I-405 SEPULVEDA PASS (PHASE 1) EXPRESSLANES PROJECT APPROVAL/ENVIRONMENTAL DOCUMENT, CONCEPT OF OPERATIONS, AND DESIGN DEVELOPMENT CONTRACT AWARD

2019-0659

AUTHORIZED ON CONSENT CALENDAR the Chief Executive Officer to award and execute a 36-month, firm fixed price Contract No. AE61156000 to WSP USA, Inc. in the amount of \$27,494,005.21 for Architectural and Engineering services to produce the I-405 Phase 1 Sepulveda Pass ExpressLanes Project Approval/Environmental Document, the Concept of Operations report and 30% design, subject to resolution of protest(s), if any.

JF	PK	MB	RG	SK	EG	JB	HS	JH	KB	JDW	MRT	AN
		C	C									C

14. SUBJECT: GRANT ASSISTANCE

2019-0661

AUTHORIZED ON CONSENT CALENDAR the Chief Executive Officer to award and execute a 36-month, firm fixed price Contract No. PS63023000 to WSP USA, Inc. in the amount of \$6,372,356 for preparing 84 grant applications and 40 additional grant applications as well as optional tasks, such as greenhouse gas analysis, drone and aerial photography, and simulations. This will support Metro and local jurisdiction grant applications to discretionary federal and state funding opportunities, subject to resolution of protest(s), if any.

**16. SUBJECT: SR-71 GAP CLOSURE PROJECT CONSTRUCTION,
PHASE 1**

2019-0703

APPROVED ON CONSENT CALENDAR:

- A. the programming of \$105,072,000 in local funds for the construction of Phase 1; and
- B. AMENDED the 2009 Long Range Transportation Plan to restate the project's southern limit from Rio Rancho Road to the Los Angeles/San Bernardino County Line (SBCL).

**17. SUBJECT: MEASURE M MULTI-YEAR SUBREGIONAL PROGRAM -
GATEWAY CITIES SUBREGION**

2019-0740

APPROVED:

- A. programming of \$27,764,900 in Measure M Multi-Year Subregional Program (MSP) - I-605 Corridor "Hot Spot" Interchange Improvements Program (Expenditure Line 61); and
- B. AUTHORIZING the Chief Executive Officer (CEO) or his designee to negotiate and execute all necessary agreements for approved projects.

JF	PK	MB	RG	SK	EG	JB	HS	JH	KB	JDW	MRT	AN
Y	Y	Y	Y	Y	A	Y	Y	Y	Y	A	A	Y

**17.1 SUBJECT: MEASURE M MULTI-YEAR SUBREGIONAL PROGRAM -
GATEWAY CITIES SUBREGION**

2019-0860

WITHDRAWN motion by Directors Garcia, Hahn and Solis that the Board direct the Chief Executive Officer to:

- A. In accordance with Metro Board policy, re-evaluate for funding the "active transportation" project elements deemed ineligible in the first round of SR-91/I-405/I-605 "Hot Spots" MSP funding, contrary to Board policy, in order for such elements to be eligible for and awarded funding in this first round.

(continued on next page)

(Item 17.1 – continued from previous page)

B. Collaborate with the Gateway Cities COG to develop a long-term approach to ensure that the transportation needs of all constituents within the "Hot Spots" project area can be met, with an emphasis on moving people, and not just vehicles, in evaluating projects for funding, and

C. Identify new sources of funding to allocate toward the Gateway Cities Subregion's ATP and Subregional Equity Program MSPs.

As part of Metro staff's January 2020 response to Motion 51 (October 2019), include recommendations that take into account Board-adopted policies, including Motion 38.3 (June 2017) and the 2028 Strategic Plan.

18. SUBJECT: TRANSIT AND INTERCITY RAIL CAPITAL PROGRAM GRANT APPLICATIONS 2019-0758

AUTHORIZED ON CONSENT CALENDAR the Chief Executive Officer to prioritize projects, commit funding match and submit grant applications to California's Transit and Intercity Rail Capital Program as detailed in Attachment A.

20. SUBJECT: MUNICIPAL ADVISORS 2019-0757

AUTHORIZED the Chief Executive Officer to award six-year bench Contract Nos. PS64441000A through PS64441000J with the firms listed in Attachment A for municipal advisory services and execute task orders under these contracts for a total not-to-exceed amount of \$6,590,000 effective January 1, 2020 through December 31, 2025, subject to the resolution of protest(s) if any.

JF	PK	MB	RG	SK	EG	JB	HS	JH	KB	JDW	MRT	AN
Y	A	A	A	Y	A	Y	Y	Y	Y	A	A	Y

22. SUBJECT: ORAL REPORT ON A LINE OPENING AND UPDATE ON RIGHT OF WAY CLEANLINESS 2019-0581

RECEIVED oral report on A Line Opening and Update on Right of Way Cleanliness.

JF	PK	MB	RG	SK	EG	JB	HS	JH	KB	JDW	MRT	AN
P	P	P	P	P	A	P	P	P	P	A	A	P

23. SUBJECT: ENGINEERING SUPPORT FOR RAIL MAINTENANCE SERVICES 2019-0728

AUTHORIZED the Chief Executive Officer to execute Contract Modification No. 4 to Contract No. PS46172000, with Gannett Fleming Transit & Rail Systems, for engineering support of rail maintenance to exercise the first-year option, for an amount of \$5,000,000, increasing the total contract not-to-exceed amount from \$16,000,000 to \$21,000,000, through April 2021.

JF	PK	MB	RG	SK	EG	JB	HS	JH	KB	JDW	MRT	AN
Y	Y	C	C	Y	A	Y	Y	C	Y	A	A	Y

24. SUBJECT: SHOP TOWELS (WYPALLS) 2019-0742

AUTHORIZED ON CONSENT CALENDAR the Chief Executive Officer to award a two-year, Indefinite Delivery, Indefinite Quantity (IDIQ) Contract No. CY63850000 to JWL Supplies, the lowest responsive and responsible bidder for Shop Towels (Wypalls). The Contract one-year base amount is \$686,565 inclusive of sales tax, and the one-year option amount is \$730,453, inclusive of sales tax, for a total contract amount of \$1,417,018, subject to resolution of protest(s), if any.

25. SUBJECT: LIQUID WASTE REMOVAL SERVICES 2019-0777

AUTHORIZED ON CONSENT CALENDAR the Chief Executive Officer to award a five-year, firm fixed unit rate Contract No. OP64570000 to Western Environmental Services for Liquid Waste Removal Services in an amount not-to-exceed \$6,961,410, effective December 16, 2019, subject to resolution of protest(s), if any.

26. SUBJECT: MEMBERSHIP ON METRO SAN GABRIEL VALLEY SERVICE COUNCIL 2019-0752

APPROVED ON CONSENT CALENDAR Leonard Pieroni for membership on Metro's San Gabriel Valley Service Council.

27. SUBJECT: ORDINANCE FOR ENFORCEMENT OF TOLL VIOLATIONS FOR THE METRO EXPRESSLANES 2019-0628

APPROVED amendment to Title 7 of the Ordinance for Enforcement of Toll Violations (Attachment A). The ordinance will become effective January 5, 2020.

JF	PK	MB	RG	SK	EG	JB	HS	JH	KB	JDW	MRT	AN
Y	Y	Y	A	Y	A	Y	Y	Y	Y	A	A	Y

31. SUBJECT: LINK UNION STATION PROJECT

2019-0769

APPROVED ON CONSENT CALENDAR:

- A. FINDING that the use of a construction manager/general contractor (CM/GC) project delivery method for the Link Union Station Project, pursuant to Public Utilities Code Sections 130242, to achieve certain private sector efficiencies by an integrated project delivery team; and
- B. a competitive solicitation of a CM/GC contract(s) to qualified proposers, pursuant to Public Utilities Code Section 130242 (e), whose proposals will be evaluated by utilizing appropriate evaluation criteria (including price) set forth in the solicitation documents.

(REQUIRED 2/3 VOTE OF THE BOARD)

**34. SUBJECT: METRO WORKFORCE INITIATIVE NOW - LOS ANGELES 2019-0722
(WIN-LA)**

RECEIVED AND FILED the status report on Metro Workforce Initiative Now - Los Angeles (WIN-LA).

JF	PK	MB	RG	SK	EG	JB	HS	JH	KB	JDW	MRT	AN
Y	A	A	A	Y	A	Y	Y	Y	Y	A	A	Y

**35. SUBJECT: FINANCIAL ADVISORY SERVICES: PRE-PROCUREMENT 2019-0798
AND PROCUREMENT FOR THE SEPULVEDA TRANSIT
CORRIDOR PRELIMINARY DEVELOPMENT AGREEMENT**

AUTHORIZED ON CONSENT CALENDAR the Chief Executive Officer (CEO) to:

- A. EXECUTE Modification No. 2 to Task Order No. PS51074-3049000 with Ernst & Young Infrastructure Advisors, LLC, (EYIA) to continue support for development and execution of a contract for a pre-development agreement (PDA) for the Sepulveda Transit Corridor project through contract award, in the amount of \$539,575 increasing the not-to-exceed Task Order value from \$1,099,280 to \$1,638,855; and
- B. INCREASE Contract Modification Authority (CMA) by \$227,915 from \$100,000 to \$327,915 in support of any unforeseen additional level of effort.

36. SUBJECT: DIVISION 20 PORTAL WIDENING AND TURNBACK FACILITY **2019-0778**

APPROVED ON CONSENT CALENDAR:

- A. minor changes to project definition and CEQA Addendum to the Final Environmental Impact Report (FEIR) for the Division 20 Portal Widening and Turnback Facility (Attachment A); and
- B. ESTABLISHED a Life-of-Project (LOP) Budget of \$801,749,577 for the Division 20 Portal Widening Turnback Project.

37. SUBJECT: 7TH AND METRO STATION RADIO REPLACEMENT **2019-0787**

INCREASED ON CONSENT CALENDAR the Life of Project (LOP) Budget for the Regional Connector Concurrent Non-FFGA Activities Project, capital project number 861228 by \$6,450,000 to a total amount of \$46,441,168. This will address critical radio system interface requirements at 7th & Metro.

38. SUBJECT: 2020 LEGISLATIVE PROGRAM **2019-0725**

APPROVED:

- A. RECEIVING the State and Federal Legislative Report;
- B. the proposed 2020 Federal Legislative Program as outlined in Attachment A; and
- C. the proposed 2020 State Legislative Program as outlined in Attachment B.

JF	PK	MB	RG	SK	EG	JB	HS	JH	KB	JDW	MRT	AN
Y	Y	Y	Y	Y	A	Y	Y	Y	Y	A	A	Y

38.1 SUBJECT: 2020 LEGISLATIVE PROGRAM **2019-0859**

APPROVED motion by Directors Ridley-Thomas, Dupont-Walker, Kuehl, Butts and Garcetti that the Board:

- A. Expand Metro's legislative agenda to support or sponsor legislation that would create new financial incentives, including an expansion of the welfare exemption for units covenanted at up to 120% of Area Median Income, to facilitate the development of affordable housing around transit; and

(Item 38.1 -continued from previous page)

B. Request that the Chief Executive Officer report to the Executive Management Committee during the January 2020 cycle with a supplemental legislative program recommendation for how to best engage and advocate on legislation concerning the supply and affordability of housing in Los Angeles County.

JF	PK	MB	RG	SK	EG	JB	HS	JH	KB	JDW	MRT	AN
Y	Y	Y	Y	Y	A	Y	Y	Y	Y	A	A	Y

39. SUBJECT: I-710 SOUNDWALL PACKAGE 2 PROJECT

2019-0796

APPROVED:

- A. HOLDING a public hearing on the proposed Resolution of Necessity; and
- B. Resolution of Necessity (Attachment B) authorizing the commencement of an eminent domain action to acquire a Permanent Footing Easement, Temporary Construction Easement (TCE) and site improvements from the property identified as Parcel E-08 (APN: 6227-027-040).

(REQUIRED 2/3 VOTE OF THE BOARD)

JF	PK	MB	RG	SK	EG	JB	HS	JH	KB	JDW	MRT	AN
Y	Y	Y	Y	Y	A	Y	Y	Y	Y	A	A	Y

40. SUBJECT: ROSECRANS/MARQUARDT GRADE SEPARATION PROJECT

2019-0801

APPROVED:

- A. HOLDING a public hearing on the proposed Resolutions of Necessity; and
- B. the Resolutions of Necessity authorizing the commencement of an eminent domain action to acquire a Utility Overhang and Temporary Construction Easement from the properties identified as Parcels RM-03 (APN: 8059-029-009) and RM-06 (APN: 8059-029-029) and to acquire a Roadway Easement and Temporary Construction Easement from the property identified as Parcel RM-33 (APN: 8069-006-018). The properties listed above are herein referred to as "Properties."

(REQUIRED 2/3 VOTE OF THE BOARD)

JF	PK	MB	RG	SK	EG	JB	HS	JH	KB	JDW	MRT	AN
Y	Y	Y	Y	Y	A	Y	Y	N	Y	A	A	Y

CLOSED SESSION WAS CANCELLED DUE TO LACK OF QUORUM.

A. Conference with Legal Counsel - Existing Litigation - G.C. 54956.9(d)(1)

1. Margaret Strowski v. LACMTA, Case No. BC 695559
2. Jonathan Aguilar v. LACMTA, Case No. BC 681858
3. City of Beverly Hills v. LACMTA, USDC Case No. CV-18-3891
-GW(SSx)

B. Public Employee Performance Evaluation - G.C. 54957(b)(1)

Titles: Chief Executive Officer, General Counsel, Board Secretary,
Inspector General, and Chief Ethics Officer.

ADJOURNED at 1:40 p.m.

Prepared by: Eric Chun
Administrative Analyst, Board Administration



Michele Jackson, Board Secretary



Board Report

File #: 2019-0848, **File Type:** Informational Report

Agenda Number: 7.

PLANNING AND PROGRAMMING COMMITTEE

JANUARY 15, 2020

EXECUTIVE MANAGEMENT COMMITTEE

JANUARY 16, 2020

SUBJECT: METRO AFFORDABLE HOUSING POLICIES AND TOOLS

ACTION: APPROVE RECOMMENDATION

RECOMMENDATION

- A. RECEIVE AND FILE Metro Affordable Housing Policies and Tools; and
- B. ADOPT the proposed amendments to the 2020 State Legislative Program Goals.

ISSUE

Housing undersupply and affordability continues to worsen and homelessness continues to increase in Los Angeles County. In an effort to help address these crises, Metro Joint Development plans to undertake a thorough and thoughtful examination of its policies to assess what Metro could do to address the deepening crisis, particularly through the Joint Development program policy and process. Thoughtful consideration of the potential policy enhancements is needed to ensure that development is feasible and preserves Joint Development program's community-focused approach.

BACKGROUND

At its July 2015 meeting, the Metro Board adopted an updated Joint Development Policy, which, among other things, established a goal that 35% of the housing units in Metro's joint development portfolio be affordable to residents earning 60% or less than the Area Median Income for Los Angeles County, as established by the US Department of Housing and Urban Development. In an effort to provide further subsidy to support such affordable housing, the 35% goal was supported by a corollary provision that allows proportional discounts (up to 30%) to the fair market/rental value of Metro-owned property used for joint development purposes.

Prior to the adoption of the new affordable housing goal, approximately 29% of housing units in Metro's joint development portfolio were affordable. Since adoption of the new policy, the percentage of completed affordable units has increased to approximately 34%, and should increase to 36% when projects that are currently in negotiations are completed. A summary of the portfolio is provided as Attachment A.

Even though Metro's efforts to date are producing significant amounts of affordable housing, there continue to be numerous challenges to producing housing units across the full spectrum of need at levels that are impactful. These challenges often involve inadequate or nonexistent funding sources that are necessary to compensate developers for the covenanted, below market rents required in affordable housing projects.

Meanwhile, housing affordability continues to worsen, and homelessness continues to increase. According to the California Housing Partnership Corporation, as of April 2018, Los Angeles County has a shortfall of 516,946 homes affordable to lower income renters. Additionally, rents in Los Angeles County have increased 25% since 2013, while incomes have only increased by 10%. Today, 56% of Los Angeles households spend more than 30% of their income on housing, the threshold at which households are considered at risk of becoming homeless. In last year's homeless count, individuals experiencing homelessness in the county have increased 12% to 58,936 individuals.

In October 2019 the California Department of Housing and Community Development issued an updated Regional Housing Needs Assessment (RHNA) determination of 1.34 million new homes in the six-county Southern California region over the next eight years. In November 2019, Southern California Association of Governments (SCAG) adopted a draft allocation methodology for this RHNA allocation. The assessment calls for the construction of approximately 819,000 new homes in LA County, of which 27% are needed for very low-income households earning less than 50% of Area Median Income. While the LA region has been constructing significant amounts of housing, in the last 8 years only 11% of the new units have been affordable, where the need is greatest. To make matters worse, 13% of subsidized units are at high risk of losing their affordability in the next 5 years due to expiring affordability covenants on those properties.

Considering these pressures, Metro Joint Development will be undertaking a thorough examination of its policies to assess what more Metro may be able to do to address the situation.

DISCUSSION

Over the next six months, Joint Development staff, with support from technical consultants, will undertake an assessment of the current Joint Development policy and identify opportunities for strengthening Metro's commitment to meeting the County's housing needs. The effort seeks to identify interventions and policy changes that will ultimately be most impactful to achieve these goals. These interventions will consider real market conditions, developer concerns, funding constraints and other Joint Development policy goals, which include preservation of properties for existing and future transit uses; increasing transit ridership; engaging with and reflecting the needs and desires of the communities surrounding Metro Joint Development projects; producing projects with high quality design; and, observing fiscal responsibility. In addition, the evaluation will consider measures supported by the Transit Oriented Communities (TOC) Policy to stabilize and enhance existing communities in partnership with local jurisdictions through policies such as inclusionary zoning, rent control or rent stabilization, just-cause eviction and other anti-displacement measures.

Potential changes/additions to the existing policy that will be evaluated include, but are not limited to:

- Changing the percentage goal for affordable housing portfolio-wide;
- Adding target ranges of affordability levels to portfolio-wide goal;

- Changing the requirements for and amount of ground lease discount available to developers;
- Setting per site minimum levels of affordable housing (a “floor”) for each Joint Development project that includes a housing component;
- Exploring alternative means of allowing developers to achieve affordable housing requirements, including Community Land Trusts (CLTs) and other types of shared equity and inclusive development models;
- Adjusting the metrics used to track housing goals, including accounting for micro-units and co-housing;
- Adjusting requirements of the Metro Affordable Transit Connected Housing (MATCH) and Transit Oriented Communities Small Business (TOC-SB) Loan Programs;
- Seeking reasonable and impactful legislative changes; and
- Assessing opportunities to address regional housing needs and greenhouse gas reductions.

In addition to affordable housing, there are a wide range of community benefits that Metro strives to achieve in its Joint Development program. For example, the Joint Development program encourages local hire through application of its Project Labor Agreement and Construction Careers Policy; the inclusion of Community Based Organizations (CBOs), Small/Disadvantaged Business Enterprise (SBE/DBE), and Disabled Veteran Business Enterprises as part of development teams; the presence of local-serving, legacy businesses as commercial tenants; and on- and off-site improvements that enhance the public realm and transit connectivity. As staff revisits policies around land discounts, the broader series of potential community benefits, and related trade-offs, will be considered as well.

Process

In the next few months, Joint Development staff, working with consultants, will conduct listening sessions and one-on-one meetings with local industry and policy stakeholders, including:

- Developers (including developers who are working or have worked on projects with Metro)
- Metro Board staff
- Cities/County/SCAG
- Non-Profits Organizations focused on affordable housing
- Other affordable housing stakeholders such as community-based organizations, philanthropic organizations, academics, large employers, etc.

Through these conversations and consultant technical analysis, the team will complete a high-level evaluation of the potential strengths and weaknesses of potential policy interventions and recommend a shortlist of policies for more detailed evaluation. Joint Development staff will then facilitate a series of roundtables stakeholders to identify preliminary policy recommendations for the Board.

2020 Legislative Program

Through the policy evaluation process staff will also identify any state legislative measures that may

facilitate or otherwise impact development of housing on Metro-owned land or provide better housing outcomes in LA County more generally. At its December 2019 meeting, the Board approved Motion 38.1, which requested that staff prepare a supplemental legislative program to address the supply and affordability of housing in Los Angeles County. The following measures are proposed to supplement the State legislative program goals presented in that meeting:

GOAL #10.16: ADVOCATE FOR POLICIES AND FUNDING THAT INCREASE THE SUPPLY AND AFFORDABILITY OF HOUSING IN LOS ANGELES COUNTY.

Proposed Activities:

Support legislation, initiatives, and programs that

- Reduce the costs and time to deliver affordable housing
- Compliment Metro's TOC Policy;
- Stabilize and enhance housing affordability in existing communities.
- Provide resources to Metro, LA County jurisdictions and other partner agencies to develop land use policies that support equitable transit-oriented communities;
- Support legislation and funding opportunities that incentivize and support the development of affordable and transit-adjacent housing;
- Work with legislators and the Governor's office to preserve and increase the ability of the Joint Development Program to deliver on its portfolio approach to achieving housing goals;
- Identify and pursue opportunities to consolidate and streamline applying for transportation infrastructure and transit-oriented development grants; and,
- Seek to program modifications that recognize Metro's land discount as a significant contribution to affordable projects.

Over the course of next year's legislative session Metro Government Relations, working with Joint Development, will bring specific legislation to the Board for consideration if it is not specifically covered by these goals. Additionally, legislation is expected next year that would revive proposals that have been previously considered by the Legislature. These include proposals to require density increases around transit projects, linking land use decisions to transportation funding as well as specific proposals relating to the implementation of the State's Sustainable Communities Strategy. As these proposals develop, staff will both keep the Board apprised of those developments and work with staff and the Board offices to develop any positions that would be appropriate for the Board to consider.

Equity Platform

The evaluation will invoke all four pillars of the equity platform. With the support of a consultant, we will start by defining and understanding the problem; bringing all stakeholders into the conversation; advancing changes that deliver beneficial outcomes to low-income households; and establishing an

on-going system for monitoring these outcomes.

DETERMINATION OF SAFETY IMPACT

The proposed assessment of affordable housing policies and tools and amendment of the legislative agenda will have no impact on safety.

FINANCIAL IMPACT

There is no financial impact related to this receive and file and amendment of the legislative agenda.

IMPLEMENTATION OF STRATEGIC PLAN GOALS

The evaluation and amendment of the legislative agenda will fulfill both Strategic Plan Goal 3.2, by seeking to catalyze transit-oriented communities with affordable housing and helping to stabilize neighborhoods, and Strategic Plan Goal 3.4 by playing a leadership role in addressing homelessness.

NEXT STEPS

Based on the findings from this process, staff will return to the Board no later than September 2020 with a summary of the study results and recommendations for updating the Joint Development policy.

ATTACHMENTS

Attachment A - Summary of Completed and Pipeline Joint Development Portfolio

Prepared by: Wells Lawson, Senior Director, Countywide Planning & Development, (213) 922-7217
Greg Angelo, Senior Director, Countywide Planning & Development, (213) 922-3815
Nick Saponara, DEO, Countywide Planning & Development, (213) 922-4313
Michael Turner, DEO, Government Relations, (213) 922-2122
Holly Rockwell, SEO - Real Estate, Transit Oriented Communities and Transportation Demand Management

Reviewed by: James de la Loza, Chief Planning Officer, (213) 922-2920

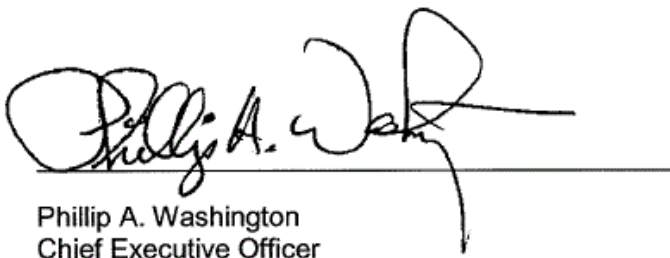

Phillip A. Washington
Chief Executive Officer

ATTACHMENT A
COMPLETED / IN PROGRESS JOINT DEVELOPMENT PROJECTS WITH HOUSING

Project	Rental		For Sale	Total Units	% Afdb	Year Complete
	Market Rate Rental	Affordable Rental				
COMPLETED						
Hollywood/Western	-	60	-	60	100%	2004
Wilshire/Vermont	359	90	-	449	20%	2005
Hollywood/Vine Apartments	300	75		375	20%	2009
Hollywood/Vine Condominiums			143	143	0%	2009
Wilshire/Western			186	186	0%	2009
Westlake/MacArthur Park (Phase A)	-	90	-	90	100%	2012
One Santa Fe	350	88	-	438	20%	2014
Taylor Yard (Lots 1, 2A, 3, 4 & 5)	-	263	95	358	73%	2014-2018
1st & Boyle - Santa Cecilia	-	80	-	80	100%	2016
Subtotal - Completed	1,009	746	424	2,179	34%	
IN NEGOTIATIONS (Current Proposals, subject to change)						
Vermont/Santa Monica		190		190	100%	
Mariachi Plaza		60		60	100%	
Chavez/Fickett		60		60	100%	
Expo/Crenshaw	320	81		401	20%	
1st/Lorena		49		49	100%	
1st/Soto		66		66	100%	
Chavez/Soto		77		77	100%	
Taylor Yard Lot 2B		42		42	100%	
North Hollywood	1216	311		1527	20%	
Subtotal - In Negotiations	1,536	936	-	2,472	38%	
TOTAL	2,545	1,682	424	4,651	36%	

Updated 12/12/2019



Next stop: building communities.

**RECEIVE AND FILE
Metro Affordable Housing Policies and Tools**

Legistar Item: 2019-0848



Recommendation



- A. RECEIVE AND FILE Metro Affordable Housing Policies and Tools;
and
- B. ADOPT the proposed amendments to the 2020 State
Legislative Program Goals.

County Context



Affordable Housing Shortfall

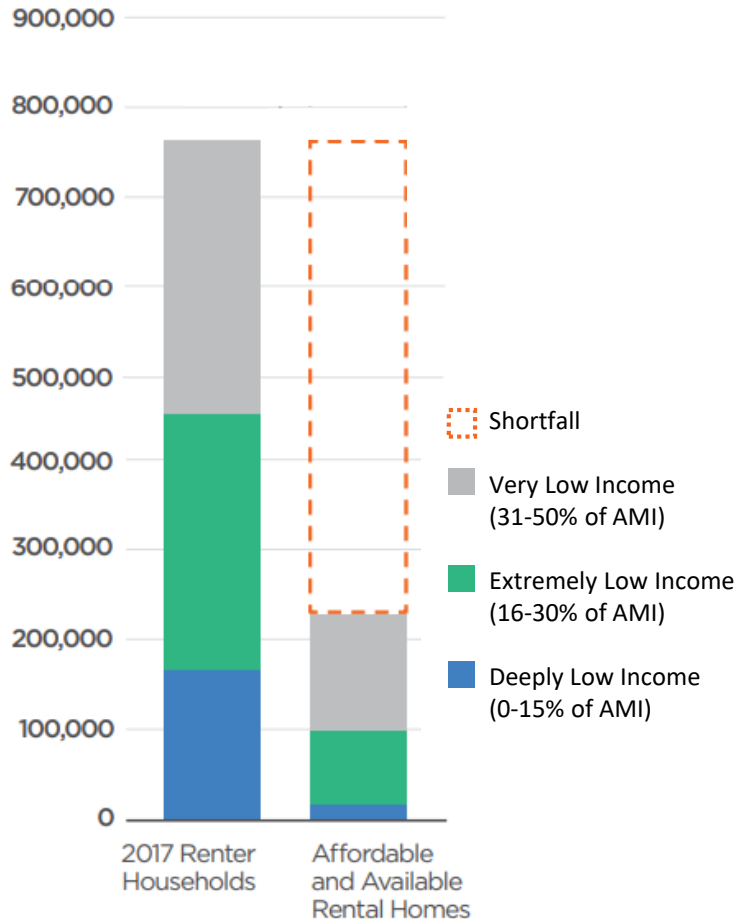

Los Angeles County Households Cost Burden

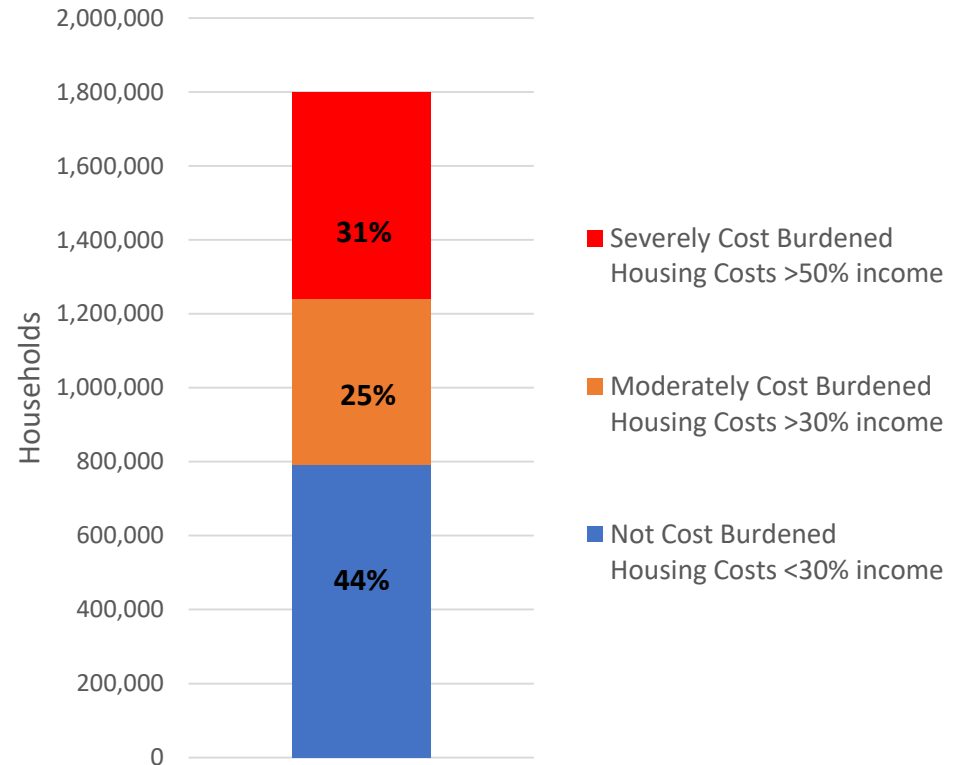

Current Joint Development Policy



- **Policy Update Adopted by Board in February 2016**
- **Establish a portfolio-wide goal of 35% affordable housing units.**
 - “Affordable” defined as 60% AMI or below.
 - Current portfolio is 34% affordable (36% including pipeline)
- **Allow for proportional discounting to projects on Metro-owned land.**
 - Maximum discount is 30%

Metro Affordable Housing Portfolio



COMPLETED / IN PROGRESS JOINT DEVELOPMENT PROJECTS

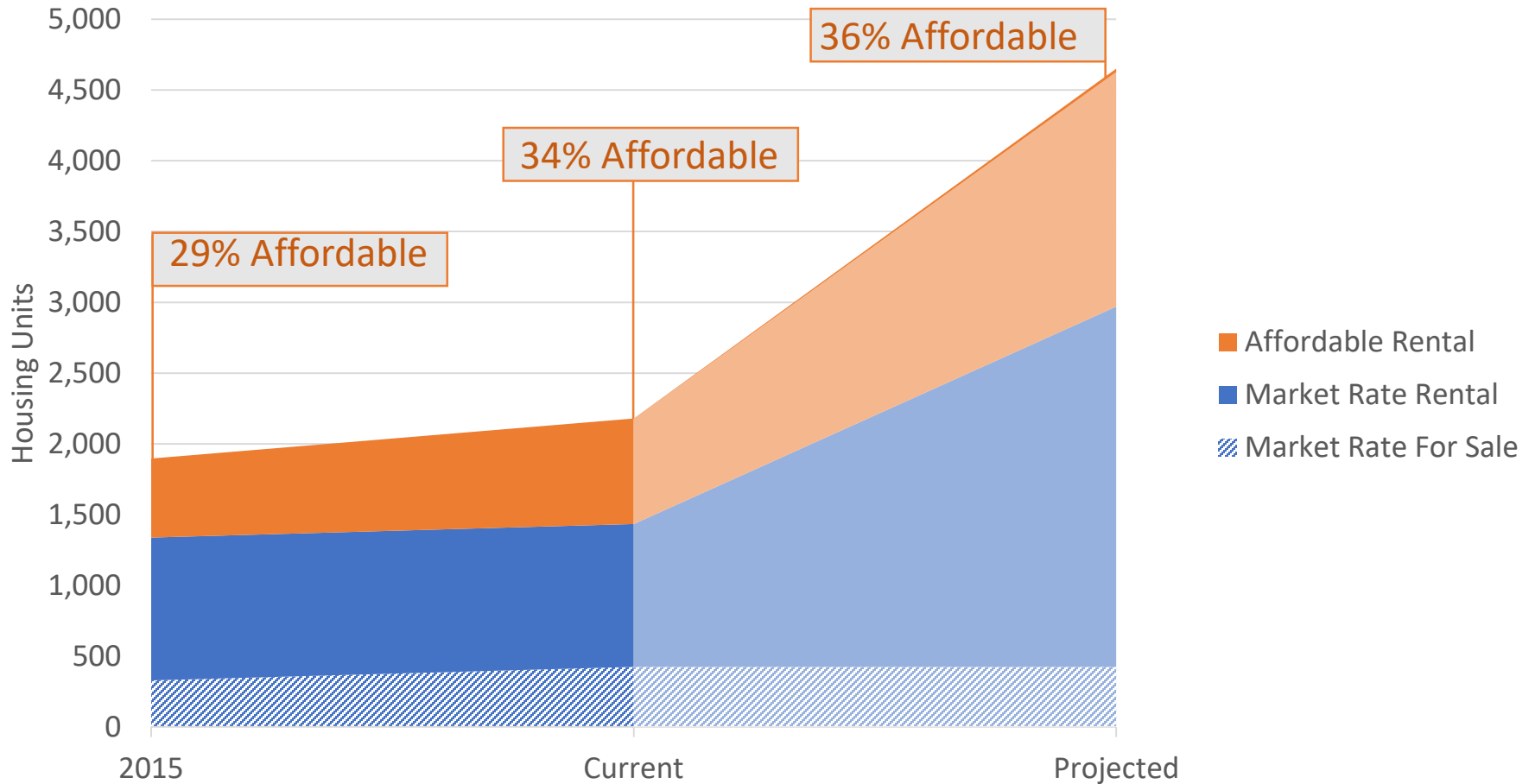

Affordable Housing Policy Next Steps



- Case Studies and Research
- Policy Brainstorm
- Feasibility Testing
- Roundtable Discussions
- Report Back to the Board

Amendment to 2020 Legislative Agenda



NEW GOAL #10.16: ADVOCATE FOR POLICIES AND FUNDING THAT INCREASE THE SUPPLY AND AFFORDABILITY OF HOUSING IN LOS ANGELES COUNTY.

Support legislation, initiatives, and programs that

- Reduce the costs and time to deliver affordable housing;
- Stabilize and enhance housing affordability in existing communities;
- Support planning for equitable transit-oriented communities;
- Incentivize and support the development of affordable and transit-adjacent housing; and
- Preserves and increases the ability of the Joint Development Program to deliver on its portfolio approach to achieving housing goals.



Board Report

File #: 2019-0807, File Type: Program

Agenda Number: 9.

PLANNING AND PROGRAMMING COMMITTEE JANUARY 15, 2020

**SUBJECT: FUNDING AWARD RECOMMENDATION FOR FEDERAL TRANSIT
ADMINISTRATION SECTION 5310 GRANT PROGRAM FUNDS**

ACTION: APPROVE RECOMMENDATIONS

RECOMMENDATION

CONSIDER:

- A. APPROVING the federal Section 5310 Enhanced Mobility for Seniors and Individuals with Disabilities Program (“Program”) recommended funding awards totaling up to \$9,926,791 for Traditional Capital and Other Capital Projects, as shown in Attachments A and B;
- B. AUTHORIZING the Chief Executive Officer (CEO) or his designee to (1) negotiate and execute pass-through agreements with the agencies approved for funding, and (2) apply \$194,400 of unused funds from past awards to the recommended funding awards;
- C. DELEGATING to the CEO or his designee the authority to administratively approve minor changes to the scope of previously-approved Section 5310 funding awards;
- D. CERTIFYING that the Section 5310 funds are fairly and equitably allocated to eligible sub-recipients and, where feasible, projects are coordinated with transportation services assisted by other federal agencies; and
- E. CERTIFYING that the projects proposed for Section 5310 funding are included in the locally-developed 2016-2019 Coordinated Public Transit-Human Services Transportation Plan for Los Angeles County (“Coordinated Plan”) that was developed and approved through a process that included participation by seniors and individuals with disabilities, as well as by representatives of public, private and nonprofit transportation and human service providers and other members of the public.

ISSUE

In April 2019, the Board approved the competitive FY 2019 solicitation process and allocation of funds for Federal Fiscal Years (FFY) 2018, 2019, and 2020 Section 5310. Applications were due on July 31, 2019. This report presents the resulting funding recommendations for Board review and approval and summarizes the evaluation process in response to this solicitation.

BACKGROUND

The Los Angeles County Metropolitan Transportation Authority (Metro) is the Designated Recipient of Federal Transit Administration (FTA) Section 5310 Program funds in urbanized areas of Los Angeles County. As such, Metro is responsible for fund planning, programming, distribution, management and sub-recipient oversight.

DISCUSSION

Program Description

The Section 5310 Program provides operating and capital assistance for public transportation projects that i) are planned, designed and carried out to meet the special needs of seniors and individuals with disabilities when public transportation is insufficient, inappropriate, or unavailable; ii) exceed the requirements of the Americans with Disabilities Act (ADA) of 1990; iii) improve access to fixed-route service and decrease reliance on complementary paratransit, and/or iv) provide alternatives to public transportation projects that assist seniors and individuals with disabilities.

Funding Availability

A total of \$10,396,358 in Section 5310 funds were made available through the solicitation process, with specific amounts allocated to the following Urbanized Areas (UZAs): \$9,843,284 for Los Angeles -Long Beach, \$232,964 for Santa Clarita, and \$320,110 for Lancaster- Palmdale. These available Section 5310 funds include FTA funds apportioned for FFY 2018, 2019 and 2020 as authorized under the Fixing America's Surface Transportation (FAST) Act.

Application Process

On April 30, 2019, a notice of funding availability with a link to the Board-approved application package was transmitted by Metro Community Relations to nearly 4,000 interested parties and potential applicants. The solicitation information was also posted on the Metro website. Metro hosted two informational workshops attended by more than 70 agencies to review program requirements, the application package, project evaluation and the selection process. Forty-three responsive applications requesting over \$13.5 million in federal grants were received by the July 31, 2019 deadline.

Evaluation and Ranking

Two evaluation panels were convened to evaluate the applications. The panels were comprised of

Metro staff and volunteers representing public transit agencies, the Bus Operations Subcommittee, the Southern California Association of Governments and a private non-profit organization (Aging and Disability Transportation Network). The average score of each evaluation panel and corresponding ranking for each project is shown in Attachments A and B. Funding was allocated to the applications ranked highest until the funds were depleted. Attachment C contains the Board-approved evaluation criteria applied by panel members in scoring the proposals.

Consistent with Board-approved guidelines, funding awards are limited to proposals with a final competitive score of 70-100. However, due to the competitive nature of this solicitation, a number of projects scoring above 70 were not recommended for funding. Preliminary funding recommendations were distributed to proposing agencies on October 17, 2019. A total of 28 projects were recommended for funding, including one that was partially funded, and 15 projects were not recommended for funding.

Technical Advisory Committee (TAC) Appeals

On November 6, 2019, TAC heard applicant appeals from five agencies supporting their preliminary fund award. After hearing the presentations, TAC approved a motion supporting the preliminary funding recommendation and recommended further that the City of Manhattan Beach receive full funding for their project, and that the City of Whittier be offered a partial award with the remaining unallocated Section 5310 balance for the LA-Long Beach UZA.

Administrative Scope Changes

Grant sub-recipients may request to re-scope their project(s) from what was approved by the Board. The proposed recommendation will delegate to the CEO or his designee the authority to administratively approve minor changes to the scope of work. Minor changes include those which meet all the following criteria: 1) The scope change is consistent with the defined project limits as approved by the Board; 2) the scope of work, as modified, continues to meet the original intent of the approved project scope; 3) to the extent that the scope change results in a reduced total project cost, the new total project cost shall be within 20% of the original total project cost; and 4) the parties shall maintain the original grant to grantee funding commitment ratio (for example, if the grantee originally committed 20% of the total project cost, with the remaining 80% comprised of Section 5310 funds, those percentages shall apply to the new total project cost).

Equity Platform

Consistent with Metro's Equity Platform, projects eligible under Section 5310 program guidelines are inherently intended to improve equity by increasing access to opportunity. Transportation is an essential lever to enable access to jobs, housing, education, health and safety. Eligible projects include those that are planned, designed, and carried out to meet the specific needs of seniors and individuals with disabilities when public transportation is insufficient, unavailable, or inappropriate. Further, the solicitation process and workshops create a forum to engage the community.

DETERMINATION OF SAFETY IMPACT

Approval of the recommendation will have no impact on safety.

FINANCIAL IMPACT

The FY20 budget includes a total of \$4,685,270 for the federal Section 5310 Program in Cost Center 0441, Subsidies to Others, under Project 500005 (Seniors and Disabilities - S5310).

Since these are multi-year projects, the cost center manager and the Chief Planning Officer will be responsible for budgeting project expenses in future years.

Impact to Budget

The sources of funds for this Program is Federal Section 5310, which is not eligible for Metro's bus and rail operating and capital budgets.

IMPLEMENTATION OF STRATEGIC PLAN GOALS

Recommendation supports the following goals of the Strategic Plan:

Goal 1: Provide high-quality mobility options that enable people to spend less time traveling; and
Goal 3: Enhance communities and lives through mobility and access to opportunity.

ALTERNATIVES CONSIDERED

The Board may choose not to approve all or some of the recommended actions. Staff does not recommend this alternative because, without Board approval, Metro cannot fulfill its responsibilities as the Designated Recipient of Section 5310 Program funds and the projects recommended for funding awards in Attachments A and B would not be implemented. Without Board approval, Metro could risk losing about \$7.4 million in Section 5310 Program funds that will lapse, if not obligated through the FTA approval process by September 30, 2020.

NEXT STEPS

With Board approval, staff will send a notification of final funding award to each project sponsor and will submit the Section 5310 grant applications to the FTA on their behalf. Once the FTA awards the grants, staff will develop and execute grant pass-through agreements with those agencies as sub-recipients. As the Designated Recipient for these funds, staff will work to ensure that sub-recipients comply with all federal rules, regulations and requirements. At the conclusion of this programming cycle, there will be remaining balances in Section 5310 fund apportionments for the Lancaster-Palmdale UZA (approx. \$236,603) and Santa Clarita UZA (approx. \$232,964). Appropriate steps to further program these balances will be pursued and reported to the Board.

ATTACHMENTS

Attachment A - Los Angeles-Long Beach-Anaheim Urbanized Areas

Attachment B - Lancaster-Palmdale Urbanized Areas

Attachment C - Evaluation Criteria

Prepared by: Anne Flores, Senior Manager, Transportation Planning, (213) 922-4894
Fanny Pan, DEO, Countywide Planning & Development, (213) 418-3433
Shawn Atlow, Executive Officer, Countywide Planning & Development, (213) 418-3327
Laurie Lombardi, SEO, Countywide Planning & Development, (213) 418-3251

Reviewed by: James de la Loza, Chief Planning Officer, (213) 922-2920

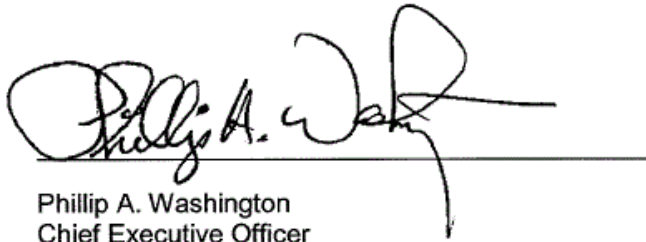

Phillip A. Washington
Chief Executive Officer

AGENCY	PROJECTS <u>RECOMMENDED</u> FOR FUNDING AWARD	SCORE	TOTAL PROJECT COST (\$)	LOCAL MATCH (\$)	VEHICLE QTY	FUNDING AWARD (\$)
1 City of Santa Monica's Big Blue Bus	Mobility is Freedom: Operating assistance to operate "Mobility on Demand Everyday" (MODE) demand response service for seniors and persons with disabilities for three (3) years.	97.00	\$2,400,000	\$1,800,000		\$600,000
2 City of Los Angeles Department of Transportation (LADOT)	2019 Cityride Replacement Vehicles: Traditional Capital assistance to procure four (4) Battery Electric Cut-Aways, and charging equipment for replacement.	96.67	\$1,656,000	\$1,056,000	4	\$600,000
3 City of Glendora	Glendora Dial-A-Ride Modernization - Replacement Vehicles and Dispatching Software: Traditional Capital assistance to procure four (4) Class V vans, and upgraded dispatching software for replacement.	96.33	\$338,121	\$33,812	4	\$304,309
4 Los Angeles Jewish Home	Services for Frail Seniors in the San Fernando Valley: Traditional Capital assistance to procure two (2) Class A buses, scheduling and dispatch system, and equipment for expansion.	95.75	\$320,697	\$32,070	2	\$288,627
5 Arts and Services for Disabled, Inc.	ASD Transportation Expansion Program: Operating assistance to continue and expand transportation program for three (3) years.	95.75	\$388,764	\$97,191		\$291,573
6 City of West Hollywood	West Hollywood Dial-A-Ride "TLC" Door-to-Door Program Extension: Operating assistance to continue "TLC" door-to-door transportation program for twenty-seven (27) months.	95.75	\$444,326	\$111,082		\$333,244
7 Pomona Valley Transportation Authority	Mobility Manager Project: Traditional Capital assistance to support the continuation and expansion of the current mobility management program.	95.17	\$480,000	\$75,000		\$405,000
8 Pomona Valley Transportation Authority ¹	Get About Minivan Replacement: Traditional Capital Assistance to procure six (6) Class D minivans for replacement.	94.67	\$216,000	\$21,600	6	\$194,400
9 Los Angeles County Metropolitan Transportation Authority (LACMTA)	On the Move Riders Program: Operating assistance to continue and expand "On the Move Riders" older adult travel training program for three (3) years.	93.75	\$510,000	\$127,500		\$382,500
10 PathPoint	Expanding Our Options - Operating: Operating assistance to operate ADA vehicles for "Expand Our Options" transportation program for two and a half (2.5) years.	93.33	\$38,647	\$9,662		\$28,985
11 PathPoint	Expanding Our Options: Traditional Capital assistance to procure one (1) Class V van with extended wheelbase for replacement, and two (2) Class V vans with extended wheelbases for expansion.	91.33	\$187,425	\$18,743	3	\$168,682
12 City of South El Monte	Dial-A-Ride Modernization Project: Traditional Capital assistance to procure one (1) Class C bus, one (1) Class D minivan, and equipment for replacement.	90.59	\$224,893	\$22,490	2	\$202,403
13 City of South El Monte	Dial-A-Ride Modernization Project: Operating assistance to operate ADA vehicles and equipment for Dial-A-Ride transportation program for three (3) years.	90.59	\$92,915	\$23,229		\$69,686
14 Valley Village	Safer Vans: Traditional Capital assistance to procure four (4) Class V vans with extended wheelbases for replacement.	89.59	\$248,000	\$24,800	4	\$223,200
15 United Cerebral Palsy/Spastic Children's Foundation of Los Angeles, Ventura and Santa Barbara Counties (UCPLA)	Replacement Vans: Traditional Capital assistance to procure ten (10) Class V vans with extended wheelbases for replacement.	89.33	\$607,500	\$60,750	10	\$546,750
16 Workforce Development, Aging and Community Services (WDACS)	Section 5310, Enhanced Mobility of Seniors and Individuals with Disabilities: Operating assistance to continue on-demand transportation program for three (3) years.	89.25	\$800,000	\$200,000		\$600,000

AGENCY	PROJECTS <u>RECOMMENDED</u> FOR FUNDING AWARD	SCORE	TOTAL PROJECT COST (\$)	LOCAL MATCH (\$)	VEHICLE QTY	FUNDING AWARD (\$)
17 The Adult Skills Center (TASC)	Adding Accessibility: Traditional Capital assistance to procure eleven (11) Class D minivans for replacement.	89.00	\$607,750	\$60,775	11	\$546,975
18 City of Pasadena	Continuation of Enhanced Accessible Mobility for Pasadena Dial-A-Ride: Operating assistance to continue and expand Dial-A-Ride transportation program for three (3) years.	88.81	\$725,082	\$181,270		\$543,812
19 The Adult Skills Center (TASC)	Adding Accessibility - Operating: Operating assistance to operate ADA vehicles for "Adding Accessibility" transportation program for two and a half (2.5) years.	88.67	\$193,001	\$48,250		\$144,751
20 City of Pasadena	Pasadena Dial-A-Ride Aging Vehicle Replacement and Expansion for Enhanced Accessibility Mobility: Traditional Capital assistance to procure two (2) Class D minivans for replacement, and one (1) Class D minivan for expansion.	88.50	\$162,000	\$16,200	3	\$145,800
21 Pearl Transit Corp	Pearl Transit: Operating assistance to implement a new 24 hour transportation and trip planning service for seniors and individuals with disabilities.	87.67	\$859,770	\$429,885		\$429,885
22 Workforce Development, Aging and Community Services (WDACS)	Section 5310, Enhanced Mobility of Seniors and Individuals with Disabilities: Traditional Capital assistance for the acquisition of transportation services under a contract.	87.00	\$666,667	\$66,667		\$600,000
23 City of Manhattan Beach	Aviation Boulevard Missing Sidewalk Project: Operating assistance to improve accessibility to the fixed-route system by installing a missing segment of sidewalk and five ADA compliant curb ramps.	87.00	\$600,000	\$60,000		\$540,000
24 Institute for the Redesign of Learning	Institute for the Redesign of Learning: Traditional Capital assistance to procure three (3) Class A buses, and two (2) Class B buses for replacement.	84.33	\$384,000	\$38,400	5	\$345,600
25 Therapeutic Living Centers for the Blind	TLC Vehicle Replacement Project: Traditional Capital assistance to procure three (3) Class V vans for replacement.	83.17	\$176,400	\$17,640	3	\$158,760
26 City of Monrovia	Monrovia Seniors and Individuals with Disabilities Service Expansion and Enhancement Projects: Operating assistance to expand and enhance senior transportation and on-demand rideshare program for three (3) years.	83.13	\$800,000	\$200,000		\$600,000
27 City of Manhattan Beach	City of Manhattan Beach Dial-a-Ride Program: Traditional Capital assistance to procure two (2) Class B buses, and two (2) Class F low floor buses for replacement.	82.33	\$514,000	\$51,400	4	\$462,600
28 City of Whittier ²	City of Whittier Dial-A-Ride Replacement Vehicles: Traditional Capital assistance to procure three (3) Class B buses, and three (3) Class D Minivans for replacement.	81.67	\$95,269	\$9,527	1	\$85,742
TOTALS			\$14,737,227	\$4,893,943	62	\$9,843,284

¹ Project funded through prior year Section 5310 funding.

² Recommended for partial funding due to funds being depleted.

AGENCY	PROJECTS <u>NOT RECOMMENDED</u> FOR FUNDING AWARD	SCORE	TOTAL PROJECT COST (\$)	LOCAL MATCH (\$)	VEHICLE QTY	FUNDING REQUEST (\$)
28 City of Whittier ³	City of Whittier Dial-A-Ride Replacement Vehicles: Traditional Capital assistance to procure three (3) Class B buses, and three (3) Class D Minivans for replacement.	81.67	\$300,731	\$30,073	5	\$270,658
29 Villa Esperanza Services ³	Transportation for Adults with Intellectual/Developmental Disabilities: Traditional Capital assistance to procure two (2) Class A buses, and two (2) Class D minivans for replacement.	77.66	\$260,000	\$52,000	4	\$208,000
30 East Los Angeles Remarkable Citizens' Association (El ARCA) ³	East Los Angeles Remarkable Citizens' Association, Inc.: Traditional Capital assistance to procure seven (7) Class B buses for replacement.	76.85	\$546,000	\$54,600	7	\$491,400
31 Independent Living Center of Southern California ^{3,4}	ILCS Ready Set Go TAP: Traditional Capital assistance to develop new travel training program.	76.10	\$177,387	\$17,739		\$159,648
32 AltaMed Health Services Corporation ^{3,4}	AltaMed's Senior Transportation Program: Traditional Capital assistance to procure a dispatch system, and equipment for Senior Transportation Program.	76.00	\$115,108	\$11,511		\$103,597
33 City of Glendale ³	Glendale Dial-A-Ride Service Expansion Vehicles: Traditional Capital assistance to procure three (3) Class V vans for expansion.	75.45	\$168,000	\$16,800	3	\$151,200
34 Westside Pacific Villages ³	Enhancements to WPV Volunteer Driving Program: Operating assistance to continue and expand WPV's volunteer driving and transportation program for three (3) years.	74.69	\$416,005	\$104,001		\$312,004
35 Westside Pacific Villages ³	2 Vehicles to Enhance SPV Transportation Services: Traditional Capital assistance to procure two (2) Class V vans for expansion.	72.25	\$118,400	\$11,840	2	\$106,560
36 White Memorial Medical Center (WMMC) ³	AHWM Transportation Service: Traditional Capital assistance to procure one (1) Class A bus for replacement.	71.13	\$78,000	\$7,800	1	\$70,200
37 White Memorial Medical Center (WMMC) ^{3,4}	White Memorial Medical Center Operations Funding: Operating assistance to operate ADA vehicles for WMMC transportation program for three (3) years.	70.13	\$298,640	\$29,864		\$268,776
38 New Horizons ³	Green Light to Mobility continuation of services: Operating assistance to continue travel training program for two (2) years.	70.00	\$587,500	\$146,875		\$440,625
39 City of Pico Rivera	Pico Rivera Transportation: Traditional Capital assistance to procure three (3) Class D minivans, and equipment for expansion.	68.33	\$317,324	\$31,732	3	\$285,592
40 City of Pico Rivera	Pico Rivera Transportation: Operating assistance to operate ADA vehicles for Dial-A-Ride transportation program for two (2) years.	67.33	\$65,600	\$16,400		\$49,200
41 City of Paramount	Dial-A-Ride Expansion: Operating assistance to expand Dial-A-Ride transportation program for three (3) years.	57.67	\$287,564	\$71,891		\$215,673
42 Pomona Valley Community Services	Community Connections Mileage Reimbursement Program: Operating assistance to continue "Community Connections" travel reimbursement program for three (3) years.	48.67	\$795,189	\$198,797		\$596,392
TOTALS			\$4,531,448	\$801,923	25	\$3,729,525

³ Although the project proposal score was within the competitive funding range, funds have been depleted.

⁴ Funding requests were adjusted to remove non-reimbursable costs.

AGENCY	PROJECTS <u>RECOMMENDED</u> FOR FUNDING AWARD	SCORE	TOTAL PROJECT COST (\$)	LOCAL MATCH (\$)	VEHICLE QTY	FUNDING AWARD (\$)
1 Antelope Valley Transit Authority (AVTA)	Enhanced Mobility for Seniors and Individuals with Disabilities: Operating assistance to implement Microtransit Services for seniors and individuals with disabilities.	70.00	\$112,800	\$29,293		\$83,507
TOTALS			\$112,800	\$29,293	0	\$83,507

FY 2019 Section 5310 Solicitation for Proposals & Application**EVALUATION CRITERIA**

The following summarizes general project narrative application requirements and the corresponding maximum points possible for each segment (100 points maximum)

A. Scope of Work, Need, Objectives, Coordination and Outreach (Up to 40 points)

- Existing services and target populations served; detail proposed scope of work including: need, objectives, changes, improvements, and how it is aligned with program goals; present project readiness/schedule; explain how program funds requested will apply to meet project requirements (20 points).
- Project goals aligned with goals and strategies of the 2016-2019 Coordinated Public Transit – Human Services Transportation Plan for Los Angeles County (10 points).
- Specific details demonstrating project development and/or implementation coordination with others (5 points).
- Marketing, promotion, public awareness plans (5 points).

B. Project Implementation, Operating and Management Plans (Up to 20 points)

- Project management plan, project milestones and deliverables, and role and experience of key personnel (8 points).
- Contingency plan details: service, staffing, mechanical, and technical (8 points).
- Prior experience and performance providing similar/same transportation related services and managing federal pass through grants. Where none, prior experience and performance in non-transit services to target populations (4 points).

C. Performance Indicators and Project Effectiveness (Up to 20 points)

- Quantitative and applicable qualitative project performance measures over the life of project showing methodology to develop estimates (10 points).
- Evaluation of project effectiveness and strategies to mitigate poor performance (4 points).
- Tools & procedures to collect, track, and report project performance (6 points).

D. Project Financial Plan / Project Readiness (Up to 10 points)

- Completion of project financial plan table with expenditure amounts by quarter.
- Description of how schedule is realistic to enable project completion.

E. Budget Justification (Up to 10 points)

- Assumptions used to prepare project budget.
- Identification of all sources and amounts of revenue and/or grants to support project
- Identification & eligibility of federal fund program requested.
- Local Match Commitment Letter with amount and source of non-USDOT local match funds committed to project, or In-Kind Match Commitment Letter with detailed description and value of eligible in-kind item or service.



Board Report

File #: 2019-0834, File Type: Program

Agenda Number: 10.

PLANNING AND PROGRAMMING COMMITTEE
JANUARY 15, 2020

SUBJECT: METRO ACTIVE TRANSPORT, TRANSIT AND FIRST/LAST MILE (MAT) PROGRAM
CYCLE 1

ACTION: APPROVE RECOMMENDATIONS

RECOMMENDATION

CONSIDER:

- A. APPROVING the Metro Active Transport, Transit, and First/Last Mile (MAT) Program Cycle 1 Solicitation; and
- B. AUTHORIZING the Chief Executive Officer (CEO) or designee to release the Program Solicitation and initiate a project selection process as described therein.

ISSUE

The approval of the MAT Program Cycle 1 Solicitation (Attachment A) is a critical step in programming funding for a discretionary program established by Measure M and prompts strategic investment toward Metro’s adopted Active Transportation Strategic Plan (ATSP). Cycle 1 of the program, as proposed, was shaped through extensive consultation with the Metro Policy Advisory Council (PAC) along with other process and input as described in this report.

BACKGROUND

The passage of Measure M created the MAT Program as a line item in the expenditure plan for \$857 million (2015 \$). The Administrative Procedures (Attachment B) for the program establish a permanent structure and process for allocating funding through periodic cycles as approved by the CEO. Of note, the procedures establish the applicable policies for the program, specify program cycles of 2-5 years in length, and delineate the steps for each program cycle to be executed.

Pursuant to the Administrative Procedures, staff, in consultation with the PAC, has developed this proposal for the first funding cycle. Cycle 1 will commit and program \$75 million in funding for five fiscal years (FYs 21-25).

The Program Solicitation establishes all the necessary program elements for this funding cycle. This includes the following, among other components:

- Identification of current program priorities;
- Detailed project and proposer eligibility definitions specific to this program cycle;
- Detailed project selection process and criteria;
- Timely use of funds provisions; and
- Public participation requirements.

DISCUSSION

The development of the approach for Cycle 1 was guided through extensive process and discussion with the PAC and its Active Transportation Working Group. In total, the PAC process consisted of seven meetings, workshop discussions, and conference calls between October 2018 and December 2019.

Key concepts informing the development of the proposed program structure include:

- **Reinforcing existing Board policies on active transportation and equity**
The MAT Program is an opportunity to align investment with existing policies such as the ATSP, Equity Platform, Vision 2028, and First/Last Mile directives, rather than create a new policy framework unique to this funding source.
- **Targeting to high-need locations**
Given a limited number of projects and limited funding, and interest in piloting funding approaches under the Equity Platform, it was determined that the program should strongly emphasize safety and equity need in prioritizing and directing funding.
- **Streamlined competitive process**
A broad competitive process similar to the Metro Call for Projects was not pursued given the relatively small number of projects that will be funded. Discussions favored a limited, invitation-to-apply model based on a potential project list consistent with established active transportation policy and an empirical analysis of need.

Description of Cycle 1 Proposal

Cycle 1 will allocate \$75 million to two program categories:

- Active Transportation Corridors
- First/Last Mile (FLM) Priority Network

As described in the Program Solicitation (Attachment A), \$37.5 million (50%) is available for each program category. Highlights of the program categories are as follows:

Active Transportation Corridors

It is anticipated that up to eight projects will be selected. Eligible projects originate from corridors identified in the ATSP (186 in total) and were screened for those that are greater than 3 miles in length. This screening yielded 160 total corridors which are considered eligible and subject to consideration for Cycle 1. Cycle 1 will fund selected corridor projects through preliminary design, environmental review and/or construction. In general, Metro anticipates leading and administering work through environmental, including procuring and managing consultants. Project sponsors would lead through subsequent phases. Jurisdictions are expected to have staff participate in project teams

as an in-kind contribution to the project. Project roles may vary from this model and may be considered on a case-by-case basis. At the conclusion of the work funded by Cycle 1, projects will be well positioned to seek other funding for final design and construction and may be considered for future cycles of the MAT program.

FLM Priority Network

It is anticipated that up to 10 projects will be selected. Eligible projects are a subset of the 661 existing transit stations and stops identified as the FLM Priority Network in the ATSP, reduced to the 269 stations for which the Board directed FLM planning activities pursuant to Motion 14.1 (Attachment C), and further screened to 138 based on a ranking of safety and equity need-based factors. Cycle 1 will fund project development through implementation of FLM improvements. For this cycle, Metro encourages FLM projects at a concentrated scale, typically up to 2 blocks, around transit stations, however, improvements up to ½ mile from stations are eligible and will be evaluated based on clear benefit and deliverability. The program as proposed is intended to test implementation approaches and partnerships, to promote early deployment of highly visible safety and user-experience improvements for the transit rider, and to position projects to pursue larger scale build-out in the future. Roles for project delivery are flexible and will be determined on a case-by-case basis. It is Metro's intention to test different partnership and delivery models in different contexts, and as such, ensuring projects in multiple jurisdictions across a diverse geography will be an additional consideration in recommending awards.

Selection Process

As shaped by PAC deliberations, the Program Solicitation follows a streamlined selection process. As noted, the program proposes, and has developed, a list of eligible project corridors and locations and a ranking methodology (included within the Program Solicitation Attachment A as sub-attachment A) based on equity, safety, and mobility/connectivity factors. As described in detail in the Program Solicitation, jurisdictions associated with highly ranked project corridors and locations will be invited to submit a Letter of Interest (LOI). Active Transportation Corridor and FLM Priority Network projects will be selected with points awarded for need-based rank order and additional points for a qualitative evaluation with criteria including, but not limited to, the following:

- Clarity of project description,
- Project support and partnerships,
- Process assurance and reasonableness of schedule,
- Leverage of other funding sources, and
- Other factors contributing to a valuable, compelling project.

A detailed description of the selection and evaluation process for Active Transportation Corridor projects and FLM Priority Network projects is included in the Program Solicitation (Attachment A) on pages 8-9 and pages 13-14, respectively.

Equity Platform

The program, as proposed, is substantially shaped by the Equity Platform. Specifically, the program integrates the four Equity Platform pillars as follows:

- I. Define and Measure: The need-based screening and prioritization methodologies

applied to projects considered a range of established equity metrics as described in (Attachment A, sub-attachment A). Per the Board's recent action adopting Equity Focused Communities (EFCs), staff assessed the screening and prioritization methodologies and determined substantial consistency with EFCs.

- II. Listen and Learn: Program development was informed by a fully participatory process with the PAC as described in this report. Further, the program requires each selected project to pursue robust community engagement and will provide guidance to project recipients to that end.
- III. Focus and Deliver: The projects selected for Cycle 1 are intended to result in visible and impactful implementation as efficiently as possible. They are further intended to inform partnership and project delivery models for future efforts.
- IV. Train and Grow: The MAT Administrative Procedures and Cycle One Program emphasize both program and project evaluation in order to inform future cycles and to incorporate lessons learned related to partnership and project delivery.

DETERMINATION OF SAFETY IMPACT

There is no direct safety impact associated with the recommended action. Note that the implementation of projects subsequent to this action is intended to improve safety conditions for pedestrians, people using bicycles and other rolling modes, and transit riders. Subsequent action related to specific projects will prompt further assessment of any potential safety impacts.

FINANCIAL IMPACT

As described in this report, the recommended action is a precursor to selecting projects with the intent of programming funding for up to \$75 million in Measure M funding for FYs 21-25. Further note that staff will seek additional Board action to formally program funds when projects have been selected.

Impact to Budget

There is no impact to the adopted budget associated with the recommended action. Funds programmed subsequent to this action are for future fiscal years. The Chief Planning Officer is responsible for ensuring that future budgets include funding for project commitments associated with this program.

Staff activities related to program development are included in the current fiscal year budget under Project 100058, Task 01.01.

IMPLEMENTATION OF STRATEGIC PLAN GOALS

The program advances several Strategic Plan Goals including:

- *Goal #1*: High-quality mobility options - advances new active transportation corridors and a full suite of first/last mile interventions at selected stations.

- *Goal #2:* Outstanding trip experiences for all - will develop and advance key station access improvements including traveler/transfer information, improved signage and wayfinding among others.
- *Goal #3:* Enhancing communities and lives - includes a clear focus on targeting investment to places that need it most due to safety, socio-economic and other factors.
- *Goal #4:* Transform LA County through collaboration and leadership - prompts new partnership models with agencies to deliver projects.

ALTERNATIVES CONSIDERED

The Board may choose to not approve the Program Solicitation at this time. This option is not recommended as it would depart from recommendations and considerations developed through substantial stakeholder process led by the PAC and would result in delay in allocating and expending Measure M funding.

NEXT STEPS

Pending approval by the Board, staff will initiate a solicitation process as described in detail, including specific schedule and milestones, in the proposed Program Solicitation. Subsequent to selection, staff will seek further action from the Board to approve a list of selected projects and to authorize actions to initiate those projects including entering into agreements. Staff anticipates returning to the Board in July 2020.

ATTACHMENTS

Attachment A - MAT Program Cycle One Solicitation
Attachment B - MAT Program Administrative Procedures
Attachment C - Metro Board Motion 14.1, May 2016

Prepared by: Jacob Lieb, Sr. Director, Countywide Planning & Development, (213) 922-4132
Cory Zelmer, DEO, Countywide Planning & Development, (213) 922-1079
Nick Saponara, DEO, Countywide Planning and Development, (213) 922-4313
David Mieger, Interim SEO, Countywide Planning & Development, (213) 418-3157
Holly Rockwell, SEO, Countywide Planning & Development, (213) 922-5585

Reviewed by: James de la Loza, Chief Planning Officer, (213) 922-2920

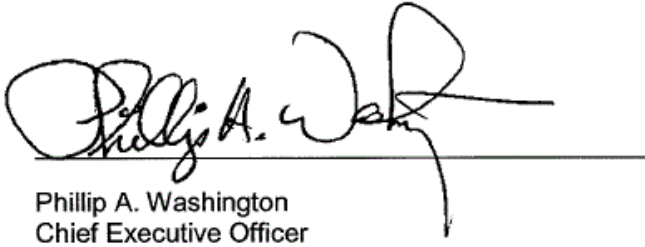

Phillip A. Washington
Chief Executive Officer

Attachment A

http://libraryarchives.metro.net/DB_Attachments/191230_MAT_Program_Cycle_One_Solicitation.pdf



Metro®



**METRO ACTIVE TRANSPORT, TRANSIT FIRST/LAST MILE PROGRAM
MEASURE M ADMINISTRATIVE PROCEDURES
SEPTEMBER 2019**

INTRODUCTION

Measure M establishes a regional Metro Active Transport, Transit First/Last Mile (MAT) Program which creates new opportunities to fulfill active transportation policies and objectives. This discretionary funding program exists with other new and on-going funding opportunities that can be used for active transportation-related purposes. These include:

- Measure M Local Return
- Measure M Multi-year Subregional Programs (MSP) geared toward active transportation and related efforts (e.g., Complete Streets);
- California's Active Transportation Program grants, as augmented in 2017 by SB1 and Cap-and-Trade; and
- Other Measure M funding, including the unallocated portion of the 2% Active Transportation Program that is part of Measure M Expenditure Plan, as well as funding committed to specific projects.

The **objectives** of the MAT Program are improving and growing the active transportation network, expanding the reach of transit, and developing a regional active transportation network to increase travel options as established in the Active Transportation Strategic Plan (ATSP, 2016). Metro policy and programs establish active transportation as an integral element to Metro's countywide transportation system and aim to foster greater active transportation usage and safety.

The adopted Measure M Guidelines establish a foundation for the MAT Program by:

- Requiring the development of these Administrative Procedures;
- Providing high level definitions of eligible activities that are further elaborated in these Administrative Procedures;
- Stipulating that the program is to be competitive; and
- Elevating safety by stipulating that projects funded through Measure M should support the protection of pedestrian and bicycle safety in parallel with Vision Zero or equivalent policies.

The MAT Program is intended to be a need-based program, with specific criteria to be determined for each funding cycle. The program will prioritize and emphasize need as demonstrated through socio-economic factors, safety for active mode users, health, and existing conditions of physical infrastructure for active modes.

These procedures apply to the MAT Program (Measure M Expenditure Plan Line 47). The Expenditure Plan identifies \$857 million (2015 dollars) for this program over 40 years.

**METRO ACTIVE TRANSPORT, TRANSIT FIRST/LAST MILE PROGRAM
MEASURE M ADMINISTRATIVE PROCEDURES
SEPTEMBER 2019**

The MAT Program will be implemented in cycles of 2-5 years. All considerations specific to each program cycle, including dissemination of a cycle-specific schedule, application process, evaluation criteria, and others are described further below. Cycles will delineate specific focus areas or priorities at the time of development. Metro may further consider areas of focus such as project scale and lead agency, noting that projects that involve partnerships between local agencies and Metro (or other regional agencies) to achieve multiple benefits are anticipated to be an on-going priority.

APPLICABLE POLICY AND USAGE

The following overarching policies are applicable to the MAT Program:

- i. Active Transportation Strategic Plan (ATSP), May 2016
Defines the Regional Active Transportation Network and establishes framework for Metro investment in active transportation. As delineated in the ATSP, the MAT Program will focus investment jointly in: 1) first/last mile networks intended to facilitate transit access; and 2) regional active transportation corridors intended to form a network for active mode travel throughout the County. The ATSP further estimates funding need in implementing a countywide vision, inclusive of first/last mile and corridors. This funding need can be used to inform priorities for each program cycle.
- ii. Equity Platform Framework, February 2018
Establishes equity as an agency priority and defines concepts and approaches for integrating equity considerations into Metro functions. The MAT program places a high emphasis on directing investments to projects prioritized using the need-based project prioritization/selection process developed with each program cycle. Further, the MAT Program will operationalize the "Focus and Deliver" equity policy pillar by placing a strong emphasis on developing and rewarding efficient and innovative delivery of needed improvements.

Supportive Policies/Strategies (listed chronologically):

- i. Countywide Sustainability Planning Policy (CSPP), December 2012
Defines sustainability principles and priorities, key concepts, planning framework, and evaluation metrics.
- ii. First/Last Mile Strategic Plan, April 2014
Defines rationale for first/last mile improvements and provides an approach to plan and design improvements surrounding any transit station.

METRO ACTIVE TRANSPORT, TRANSIT FIRST/LAST MILE PROGRAM
MEASURE M ADMINISTRATIVE PROCEDURES
SEPTEMBER 2019

- iii. Complete Streets Policy, October 2014
Creates and establishes complete streets commitments and planning process. Of note: requires that local agencies applying for Metro discretionary competitive programs have a complete streets policy in compliance with state law.
- iv. First/Last Mile Motion 14.1, May 2016
Designates 661 station areas from the ATSP as the Countywide First/Last Mile Network and directs several first/last mile planning and implementation activities. Furthermore, requires inclusion of first/last mile implementation as part of new Metro transit projects.
- v. First/Last Mile Motion 14.2, June 2016
Allows locally funded first/last mile improvements to be counted toward the 3% local match requirement for rail transit projects. Policy has been further refined by local match provisions in the adopted Measure M Guidelines and is pending additional provisions in First/Last Mile Guidelines for transit capital projects (to be developed in 2019).
- vi. Design for Safety/Vision Zero
Established by language in Measure M Guidelines (adopted June 2017): "Projects funded through Measure M should support the protection of pedestrian and bicycle safety in parallel with Vision Zero or equivalent policies." Note that this provision does not require adopted vision zero or equivalent policies of fund recipients, but does specify that Measure M funded projects should be designed for safety benefits for active mode users.
- vii. Procurement Policies (various)
Note that any project/procurement led by Metro is subject to Metro's Small Business Enterprise/Disabled Veterans Business Enterprise (SBE/DVBE) and Disadvantaged Business Enterprise (DBE) goals. Non-Metro funding recipients are subject to their own procurement policies, and are strongly encouraged to provide consideration for small, disadvantaged, and veteran-owned firms.
- viii. Other/Future Policies
Any policy adopted by the Metro Board may be applicable to this program by Board action.

**METRO ACTIVE TRANSPORT, TRANSIT FIRST/LAST MILE PROGRAM
MEASURE M ADMINISTRATIVE PROCEDURES
SEPTEMBER 2019**

PROGRAM REQUIREMENTS

1. Eligible Uses

As defined in the Measure M Ordinance, Active Transportation consists of “non-motorized transportation via walking, bicycling, or rolling modes”. Eligible projects are comprised of capital expenditures that achieve these program goals. Projects selected through the MAT Program may be funded for work preceding the environmental phase, but such expenditures are limited to .5% of overall program funding within each cycle. Projects receiving funding from the MAT Program need not be funded by the MAT Program for all phases (e.g. may use MAT funds for design/environmental phases and seek other funds for construction). Project readiness provisions established in adopted Measure M Guidelines apply (pages 14, 26, and 28).

Any project funded through the MAT Program will deliver core active transportation infrastructure, such as: sidewalks, crosswalks, bicycle lanes/paths, pedestrian/bike signal improvements, lighting, and transit amenities. Projects which provide active transportation infrastructure, but for which the primary purpose is an unrelated benefit (e.g. utility relocation) are considered ineligible. Other eligible project components may include: shade structures, landscaping, signage, and other improvements that support the aid and comfort of active transportation users. Each program cycle may establish further requirements or limitations regarding permissible project component expenditures.

2. Eligible Recipients

Cities, County of Los Angeles, Caltrans, and transit agencies are eligible to receive funding through this program. Other transportation-related public joint powers authorities (JPAs) must be sponsored by one of the above public agencies.

3. Program Cycles

Program cycles will occur every 2-5 years, with each cycle initiated by the dissemination of a detailed schedule. The “Process” section below further delineates the steps, required components, and considerations for each program cycle.

4. Performance Evaluation/Metrics

Metro will evaluate the effectiveness of the MAT Program through the application of performance metrics. Metro will develop performance metrics within the first program cycle, and subject to revision in future cycles. Metrics developed for the MAT Program will be informed by Measure M goals, applicable policies as listed herein, subsequent policies (such as the Long Range Transportation Plan), and those identified for other Measure M programs, notably MSP (refer to Measure M Administrative Procedures, page 11). Metro will provide retrospective evaluation of each program cycle. Metro may require recipients of MAT Program funds to submit project performance information to contribute to the program cycle evaluation.

**METRO ACTIVE TRANSPORT, TRANSIT FIRST/LAST MILE PROGRAM
MEASURE M ADMINISTRATIVE PROCEDURES
SEPTEMBER 2019**

5. Public Participation Plan

Each MAT Program cycle will be informed by a public engagement process subject to requirements determined by the Measure M Public Participation Plan.

6. Readiness

All Measure M programs strongly emphasize efficient project delivery and timely use of funds. As such, projects or programs will obligate Measure M funds at the time they are ready to use them. It is important that project sponsors provide accurate information for evaluating project readiness. Each program cycle will delineate requirements to demonstrate project readiness and expend funds in a timely manner. Requirements may include:

- Narrative description establishing reasonableness of the project schedule;
- Right-of-way acquisition details (if any);
- Utility relocation details (if any);
- Warranty of permit(s) approval;
- Commitment of local agency and community support for the project;
- Identification of all other agencies or organizations that are active participants in the project. Indicate how and when their involvement is required in order to implement the project.
- Demonstrated support of project sponsor's governing body; and
- Certification that all complementary fund sources are committed to the project. Funding is considered committed if it is included specifically in a programming document adopted by the governing board or council responsible for the administration of the funding and recognized by Metro as available for the phase at the time the funds are needed.
- For projects where phases are programmed separately, phase-specific readiness criteria will apply, and will be further delineated in the program cycle, as applicable.

PROCESS

1. Schedule

To initiate each program cycle, Metro will provide potential applicants/recipients with notification and information regarding the program, including a schedule. This information shall be disseminated no less than 3 months in advance of Board adoption of the program cycle (Step 4).

**METRO ACTIVE TRANSPORT, TRANSIT FIRST/LAST MILE PROGRAM
MEASURE M ADMINISTRATIVE PROCEDURES
SEPTEMBER 2019**

2. Fund Estimate

Metro will provide an estimate of available funding for the program cycle as a subset of the five-year cashflow forecast.

3. Program Development

Metro will develop a program cycle document, subject to Board adoption, that shall include the following elements:

- a. Schedule;
- b. Priorities;
- c. Criteria for project selection;
- d. Criteria for matching grant program, as applicable;
- e. Program sub-categories, as applicable;
- f. Project requirements (e.g. required project elements, design consideration, minimum/maximum size, etc.);
- g. Application requirements;
- h. Program Evaluation Metrics; and
- i. Public Participation Plan

4. Program Cycle Adoption

The Metro Board shall adopt a program for each cycle inclusive of all elements in (3) above, based on recommendations from Metro staff. The program cycle recommendation for adoption may include authorization to conduct a solicitation process to identify and award project funds, along with authorization to enter into funding agreements with selected project sponsors.

5. Solicitation Process (for competitive/match for local projects):

The adopted program cycle shall establish criteria and a process for awarding projects funds through a competitive solicitation. Note that the competitive process described for the program cycle may be a limited competition open to projects/project locations screened and prioritized according to need-based and other criteria. The competitive solicitation process shall be geared to implementing Metro policies/programs and in consideration of other criteria such as leverage, community support, and benefit to disadvantaged communities. The program cycle may further describe criteria for a matching grant program intended to provide matching funds for projects seeking state or federal grant funds. The priorities, process, and requirements for any matching grant effort shall be delineated in the program cycle.

Following project selection, Metro will publish a final project list using criteria based on MAT Program priorities. The project list will include, at a minimum, the following information:

- Project Sponsor;
- Project Description;

**METRO ACTIVE TRANSPORT, TRANSIT FIRST/LAST MILE PROGRAM
MEASURE M ADMINISTRATIVE PROCEDURES
SEPTEMBER 2019**

- Cycle Funding Forecast (by year); and
- Other Measure M Funding Forecast (as applicable).

6. Annual Update/Lapsing

Metro staff may propose updates of the project list on an annual basis. Updates are intended to accommodate changes in the project list and/or funding assumptions, including timelines. Projects are expected to expend project phase funds within three years from the date the funding agreement was fully executed. Failure to expend funds as programmed may result in lapsing and Metro may rescind awards. Any project programmed that does not request allocation of funds in the year of programming may, at the discretion of Metro, have its funding deobligated and reprogrammed to other projects either by award to the highest ranked previously unfunded project or through new competitive solicitation. Sponsors may have the opportunity to reapply for funds through these solicitations, but will not be guaranteed any priority if other eligible, ready-to-go project applications are received. Lapsing may also be triggered by additional specific project milestones identified in project funding agreements.

7. Funding Agreement

Metro will enter into funding agreements with awarded agencies. Funding agreements will be authorized as part of the program cycle Board adoption described in (4) above.

APPROVED:

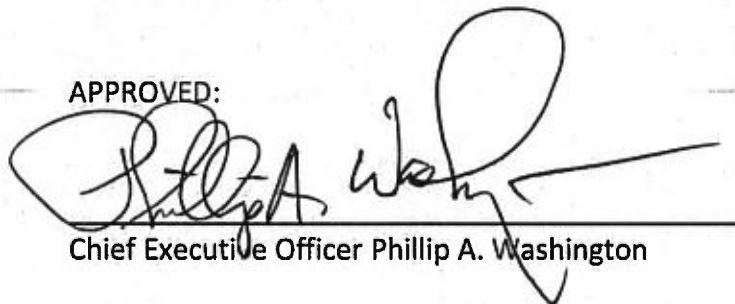

Chief Executive Officer Phillip A. Washington

9/10/2019
Date



Metro

Board Report

File #:2016-0442, **File Type:**Motion / Motion Response

Agenda Number:14.1

PLANNING AND PROGRAMMING COMMITTEE MAY 18, 2016

Motion by:

Directors Garcetti, Bonin, Kuehl, Solis, DuBois and Najarian

May 18, 2016

Item 14, File ID 2016-0108; First-Last Mile

According to MTA data, 76 percent of Metro Rail customers and 88 percent of Metro Bus customers arrive at their station or stop by walking, biking, or rolling. To support these customers, MTA staff prepared an Active Transportation Strategic Plan which contains many First-Last Mile improvements that will connect people to MTA's transit network and maximize the benefits from transit investments being made across Los Angeles County.

First-Last Mile elements include, but are not limited to, ADA-compliant curb ramps, crosswalk upgrades, traffic signals, bus stops, carshare, bikeshare, bike parking, context-sensitive bike infrastructure, and signage/wayfinding. The Federal Transit Administration considers First-Last Mile infrastructure to be essential to providing safe, convenient, and practical access to public transportation.

So far, MTA has taken important preliminary steps to implement First-Last Mile projects, including the award-winning 2014 Complete Streets Policy, the Wayfinding Signage Grant Pilot Program, providing carshare vehicles at Metro Rail stations, and pilot First-Last Mile infrastructure at Arcadia, Duarte, Expo/Bundy, and 17th Street/SMC stations.

However, more can be done to support First-Last Mile facilities across all of Los Angeles County.

MTA's award-winning Complete Streets Policy stated that MTA would approach every project as an opportunity to improve the transportation network for all users. However, in practice, there is a needlessly narrow approach to major transit projects that has resulted in many missed opportunities to deliver First-Last Mile elements.

Outside of major transit projects, it will typically not be MTA's role to deliver First-Last Mile projects that are the purview of local jurisdictions. However, MTA can take steps to meaningfully facilitate and help local jurisdictions deliver First-Last Mile projects through a variety of means.

File #:2016-0442, **File Type:**Motion / Motion
Response

Agenda Number:14.1

To support regional and local transit ridership across Los Angeles County, it is time for MTA to reaffirm its dedication to the delivery of First-Last Mile facilities across all of Los Angeles County.

APPROVE Motion by Garcetti, Bonin, Kuehl, Solis, DuBois and Najarian that the Board adopt the Active Transportation Strategic Plan (Item 14); and,

WE FURTHER MOVE that the Board direct the CEO to:

- A. Designate streets within the Active Transportation Strategic Plan's 661 transit station areas as the Countywide First-Last Mile Priority Network;
- B. To support regional and local transit ridership and facilitate build-out of the Countywide First-Last Mile Priority Network, including, but not limited to, ADA-compliant curb ramps, crosswalk upgrades, traffic signals, bus stops, carshare, bikeshare, bike parking, context-sensitive bike infrastructure (including Class IV and access points for Class I bike infrastructure), and signage/wayfinding:
 1. Provide technical and grant writing support for local jurisdictions wishing to deliver First-Last Mile projects on the Countywide First-Last Mile Priority Network, including providing technical assistance and leadership to jurisdictions to help and encourage the implementation of subregional networks that serve the priority network;
 2. Prioritize funding for the Countywide First-Last Mile Priority Network in MTA grant programs, including, but not limited to, the creation of a dedicated First-Last Mile category in the Call for Projects;
 3. Create, and identify funding for, a Countywide First-Last Mile Priority Network Funding Match Program, separate from existing MTA funding and grant programs, for local jurisdictions wishing to deliver First-Last Mile projects on the Countywide First-Last Mile Priority Network;
 4. To support the Active Transportation Strategic Plan, dedicate funding for the Countywide First-Last Mile Priority Network in the ongoing Long-Range Transportation Plan update, including a review of First-Last Mile project eligibility for all Prop A, Prop C, and Measure R capital funding categories;
 5. Building on MTA's underway effort to conduct First-Last Mile studies for Blue Line stations, conduct First-Last Mile studies and preliminary design for First-Last Mile facilities for all MTA Metro Rail stations (existing, under construction, and planned), all busway stations, the top 100 ridership Los Angeles County bus stops, and all regional rail stations;
 6. Incorporate Countywide First-Last Mile Priority Network project delivery into the planning, design, and construction of all MTA transit projects ~~starting with the Purple Line Extension~~

File #:2016-0442, **File Type:**Motion / Motion
Response

Agenda Number:14.1

Section 2 project. These Countywide First-Last Mile Priority Network elements shall not be value engineered out of any project; and staff to report back at the June Planning and Programming Committee on the Purple Line Extension Section 2 Project.

C. Report on all the above during the October 2016 MTA Board cycle.

AMENDMENT by Solis to include Foothill Gold Line Phase 2B Extension to Claremont.



Next stop: access to opportunity.

Metro Active Transport (MAT) Program
Planning and Programming Committee
Legistar 2019-0834
January 15, 2020



Recommendation

1. Approve

- Metro Active Transport, Transit and First/Last Mile (MAT) Program Cycle 1

2. Authorize

- CEO or designee to initiate a project selection process

Active Transportation Funding

Measure M established a 2% Active Transportation Fund

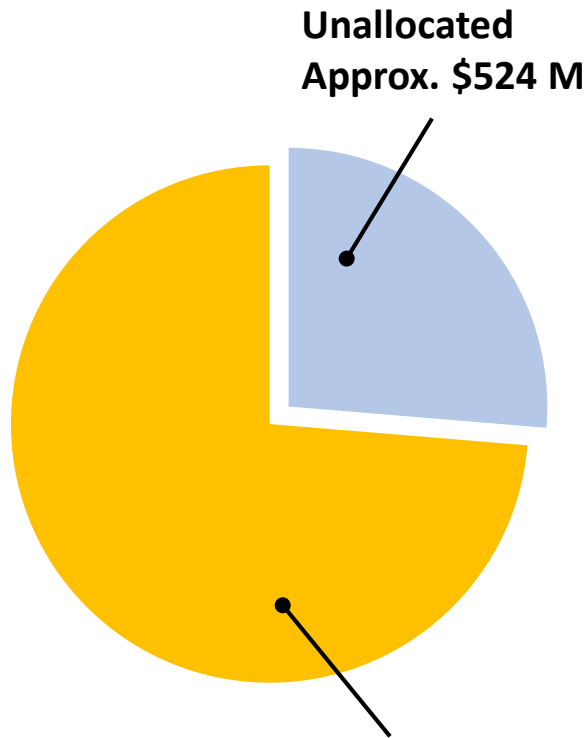

Specified/Allocated:

- MAT Program Approx. \$1.68 B*
- LA River Path Approx. \$58 M**

Metro Active Transport (MAT) Program

- \$1.68 billion Measure M funding (*adjusted for inflation*)
- Multi-year, competitive program
- Regular cashflow (Cycle 1 - \$75 M through FY25)
- Administrative Procedures (approved Sept. 10)

PAC Guidance

- Streamline process
- Implement existing policies
- Target to need

Cycle 1 Overview: Categories

Active Transportation Corridors

Objectives/Benefits

- Move Active Transportation Strategic Plan (ATSP) regional network vision into action
- Create partnerships for regional scale corridors
- Target high need; prompt complex projects
- Create pipeline for future investment

Cycle 1 Funding

- Up to 8 Projects
- \$4 - 8 M each
- Conceptual development through construction

FLM Priority Network

Objectives/Benefits

- Move ATSP vision for station areas into action
- Test FLM Toolkit/Pilot streamlined delivery
- Target high need
- Create highly visible “transit zones”
- Create pipeline for future investment

Cycle 1 Funding

- Up to 10 projects
- \$500 K - 5 M each
- Conceptual development through construction

Cycle 1 Eligible Project List Development

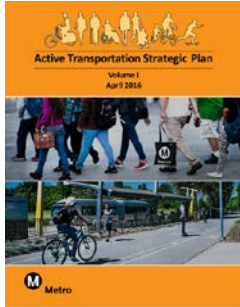

Eligible Projects Originated from ATSP (adopted 2016):

- 186 Active Transportation Corridors
- 661 stations and stops

Active Transportation Corridors

Screening Criteria

- Greater than 3 miles in length
- Identified 160 total corridors
- Ranked by safety, equity, connectivity factors

Eligible Project List

- Top 25 invited to apply

FLM Priority Network

Screening Criteria

- FLM Policy (Board Motion 14.1) identified 269 stations
- Ranked by safety, equity, connectivity factors

Eligible Project List

- Top 138 locations invited to apply

Cycle 1 Timeline

PROGRAM DEVELOPMENT

- **Oct 2018- Jun 2019:** Policy Advisory Council/Working Group (4 meetings)
- **August 26, 2019:** Notice of Cycle Initiation
- **Sept 10, 2019:** Approval of Administrative Procedures
- **Sept 10, 2019:** Program Workshop

UPCOMING

- **Feb 2020:** Solicitation Opens
- **Apr 2020:** Letters of Interest Due
- **May 2020:** Project Selection
- **July 2020:** Board Consideration of Selected Projects
- **Sep 2020:** Agreements / Project Initiation



Board Report

File #: 2019-0838, **File Type:** Program

Agenda Number: 11.

**PLANNING AND PROGRAMMING COMMITTEE
JANUARY 15, 2020**

SUBJECT: MEASURE R HIGHWAY SUBREGIONAL PROGRAM SEMI-ANNUAL UPDATE

ACTION: APPROVE RECOMMENDATIONS

RECOMMENDATION

CONSIDER:

- A. APPROVING \$109,537,000 of additional programming within the capacity of the Measure R Highway Subregional Programs and funding changes via the updated project list as shown in Attachment A for:
- Highway Operational Improvements in Arroyo Verdugo
 - Highway Operational Improvement in Las Virgenes Malibu
 - I-405, I-110, I-105 and SR-91 Ramp and Interchange Improvements (South Bay)
 - I-605 Corridor “Hot Spots” Interchange Improvements in Gateway Cities
 - I-710 South and/or Early Action Projects in Gateway Cities
- B. APPROVING deobligation of \$1,390,000 dollars of previously approved Measure R Highway Subregional Program funds for re-allocation at the request of project sponsors;
- C. AUTHORIZING the CEO or his designee to negotiate and execute all necessary agreements for the approved projects.

ISSUE

The Measure R Highway Subregional Program update approves additional eligible projects for funding and allows the Metro Highway Program and each subregion or lead agency to revise scopes and schedules and amend project budgets. This update includes projects which have received prior Board approval, changes related to schedules, scope, funding allocation for addition or removal of projects. The Board’s approval is required as the updated project lists serve as the basis for Metro to enter into agreements with the respective implementing agencies.

BACKGROUND

Line 31,32,33,35,37,38 and the 2008 Measure R Expenditure Plan addresses the Highway Operational Improvement Subfunds. As part of its responsibility, Metro Highway Department manages the development and implementation of subregional highway projects.

To be eligible for funding, subregional highway projects must improve traffic flow in an existing State Highway corridor by reducing congestion and operational deficiencies. Updates on progress in development and implementation of the subregional highway programs are presented to the Board twice a year.

DISCUSSION

The Measure R Expenditure Plan included the following Highway Capital Projects Subfunds:

- Highway Operational Improvements in Arroyo Verdugo
- Highway Operational Improvements in Las Virgenes Malibu
- I-405, I-110, I-105 and SR-91 Ramp and Interchange Imp. (South Bay)
- I-605 Corridor “Hot Spots” Interchange Imp. in Gateway Cities
- State Route 138 Capacity Enhancements in North County

The Subregional Highway capital projects are not fully defined in the Measure R Expenditure Plan. Eligible projects are identified by project sponsors and validated/and recommended for Board approval by Metro Highway Program staff for funding.

The changes in this update include \$109,537,000 in additional programming for 12 new and 15 existing projects in Arroyo Verdugo, Las Virgenes Malibu, Gateway Cities and South Bay subregions- as detailed in Attachment A.

A nexus determination has been completed for each new project. All projects on the attached project list provide highway operational benefits and meet the Highway Operational and Ramp/Interchange improvement definition approved by the Board.

Highway Operational Improvements in Arroyo Verdugo

The subregional list has 60 projects to be funded by Measure R Highway Subregional Funds. Of those, 16 projects have been completed. The subregion has invested \$39 million of Measure R subregional highway funds in projects. The 28 active projects are in planning, design, or construction phases. This update includes 6 new projects and funding adjustments to 4 approved projects as follows:

Burbank

- Program \$200,000 in FY21 and \$1,200,000 in FY22 for the MR310.55 - I-5 Corridor Arterial Signal Improvements Phase 3. The funds will be used for the design and construction of traffic signal system improvements at three intersections: Victory Blvd at Elmwood Dr, Magnolia Blvd

at Mariposa St, and Magnolia Blvd at Reese Pl.

Measure R NEXUS to Highway Operational Definition: The project is an eligible Highway Operational Improvement Project which will upgrade traffic signals/surveillance/detection. The three traffic signals are on two major corridors that are within one mile of the I-5 Freeway. Upon completion, the project will enable real time traffic signal changes and responsive operations will reduce vehicle hours of delay and improve traffic flow and public transit efficiency.

- Program \$250,000 in FY21 for MR310.56 - Victory Blvd and Buena Vista St Signal Synchronization. The funds will be used for the design and implementation of signal synchronization for 24 traffic signals on Victory Blvd between Buena Vista St and Alameda Ave and Buena Vista St between Glenoaks Blvd and I-5 freeway. The project will improve traffic operations on major arterials along Interstate 5.

Measure R NEXUS to Highway Operational Definition: Victory Blvd and Buena Vista St are within one mile of the I-5 freeway. Victory Blvd is used as an alternate route when the I-5 freeway is heavily congested. Buena Vista St provides direct on ramp access to the I-5 freeway. The project is an eligible Highway Operational Improvement Project. Upon completion, the project will enable signal timing changes that will reduce vehicle hours of delay; and improve traffic flow and public transit efficiency.

- Program \$350,000 in FY22 for MR310.57 - Olive Avenue and Glenoaks Boulevard Signal Synchronization Project. The funds will be used for design and implementation of signal synchronization for 39 traffic signals on Olive Avenue between Glenoaks Boulevard and Lakeside Drive and Glenoaks Boulevard between Buena Vista Street and Alameda Avenue. The project will improve traffic operations on major arterials along the State Route 134 and Interstate 5 corridors.

Measure R NEXUS to Highway Operational Definition: Olive Ave and Glenoaks Blvd are within one mile of the I-5 and SR- 134 Freeways. Glenoaks Blvd runs parallel to the I-5 Freeway and is used as an alternate route when the I-5 freeway and is heavily congested. Olive Ave provides an adjacent connection between SR-134 and the I-5. The project is an eligible Highway Operational Improvement Project. Upon completion, the project will enable signal timing changes that will reduce vehicle hours of delay; and improve traffic flow and public transit efficiency.

- Program \$250,000 in FY23 for MR310.58 - Downtown Burbank Signal Synchronization. The funds will be used for design and implementation of signal synchronization for 30 traffic signals on San Fernando Boulevard between Grismer Avenue and First Street, First Street between San Fernando Boulevard and Verdugo Avenue, San Fernando Boulevard between Magnolia Boulevard and Elmwood, Third Street between Burbank Boulevard and Verdugo Avenue. The project will improve traffic operations on three arterials parallel to Interstate 5.

Measure R NEXUS to Highway Operational Definition: All three corridors run parallel to the I-5 Freeway. The project is an eligible Highway Operational Improvement Project. Upon completion, the project will reduce vehicle hours of delay and improve traffic flow and public transit efficiency.

- Program \$500,000 in FY20 and \$1,500,000 in FY21 for MR310.59 - Burbank Los Angeles River Bicycle Bridge. The total project budget is \$2,000,000. The funds will be used for the design and construction of a bicycle and pedestrian bridge across the Los Angeles River in Burbank and Los Angeles. The project will include approximately 340 feet of Class III bike lanes on a portion of Bob Hope Drive, a new bridge structure spanning the Los Angeles River, and a short Class I bike path connecting the bridge to Forest Lawn Drive.

Measure R NEXUS to Highway Operational Definition: This is a bike path / bridge project located parallel to and within one mile of State Route 134 and is within the 20 percent share of Arroyo Verdugo Highway Operational Improvement funding eligible for bike routes and sound walls.

Glendale

- Reprogram \$100,000 from FY19 to FY 22 and \$500,000 from FY20 to FY23 for MR310.36 - Signalization at SR-2 Freeway Ramps at Holly Drive. The total programmed budget remains unchanged at \$600,000. The City has delayed implementation of the project as they need to conduct additional studies and hold stakeholder meetings.
- Program an additional \$350,000 in FY20 for MR310.37 - Verdugo Blvd Traffic Signal Modification at Valihi Way and SR-2. The total revised project budget is \$1,450,000. The city advertised the project and bids came higher than expected. The additional funds will fully fund the construction phase of the project.
- Reprogram \$150,000 from FY19 to FY 22 and \$1,050,000 from FY20 to FY23 for MR310.39 - Widening of SR-2 Freeway Ramps at Mountain Street. The total programmed budget remains unchanged at \$1,200,000. The City has delayed implementation of the project as they need to conduct additional studies and hold stakeholder meetings.
- Reprogram \$585,000 from FY20 to FY 21 and \$1,065,000 from FY21 to FY22 for MR310.43 - Verdugo Rd Street Improvements Project (Traffic Signal Modification). The total programmed budget remains unchanged at \$1,650,000. The City has delayed implementation of the project as they need to conduct additional studies and hold stakeholder meetings
- Program \$1,100,000 in FY21 for N. Verdugo Rd Traffic Signal Modifications Project. The funds will be used for the design and construction of signal systems at five intersections on Verdugo Rd: Glorietta Ave, Fern Ln, Wabasso Wy, Cresmont Ct, and Verdugo Loma Dr.

Measure R NEXUS to Highway Operational Definition: The project will enhance traffic flow, reduce delays and improve vehicular access to and from the I-210, SR-2, and SR-134 freeways from Verdugo Rd, a principal arterial roadway that carries high traffic volumes to and from the freeway on and off ramps at Mountain St to the east, Glendale Ave to the south, and Verdugo Blvd to the north. The project is an eligible Highway Operational Improvement Project. Upon completion, this project will enable real time traffic signal timing change and responsive operations which will reduce vehicle hours of delay and improve traffic flow and public transit efficiency.

Highway Operational Improvements in Las Virgenes Malibu Subregion

The subregion had listed 26 projects to be funded by Measure R Highway Subregional Funds. Of those, 11 projects have been completed. The subregion has invested \$117 million of Measure R subregional highway funds in projects. The 11 active projects are in planning, design, or construction phases. This update includes funding adjustments to 3 existing projects as follows:

Agoura Hills

- Deobligate \$550,000 from MR311.03 - Palo Comado Interchange Project. The revised project budget is \$10,450,000. This project is fully funded and currently is in construction. Funds are being deobligated to develop other Measure R projects.
- Program an additional \$350,000 in FY20 for MR311.04 - Kanan/Agoura Road Intersection. The total revised project budget is \$1,150,000. The funds will be used to complete the design phase of the project.
- Program an additional \$200,000 in FY20 for MR311.05 - Agoura Road Widening. The total revised project budget is \$36,700,000. The funds will be used to complete the construction phase of the project by providing additional funds for the oak tree mitigation for the project.

I-405, I-110, I-105 and SR-91 Ramp and Interchange Improvements (South Bay)

The subregion had listed 80 projects to be funded by Measure R Highway Subregional Funds. Of those, 19 projects have been completed. The subregion has invested \$90 million of Measure R subregional highway funds in projects. The 60 active projects are in planning, design, or construction phases. This update includes funding adjustments to 4 existing projects as follows:

Carson

- Metro will manage and complete the design for MR312.41 - Traffic Signal Upgrades at 10 intersections and MR312.46 - Upgrade Traffic Control Signals at the Intersection of Figueroa St and 234th St. and Figueroa and 228th St. Metro will be added as a co-lead agency for

project development, as requested by the City of Carson.

Caltrans

- Program an additional \$70,000 in FY20 for MR312.78 - I-405 IQA Review for PSR (Main St. to Wilmington). The revised project budget is \$150,000. The additional funds are required for Caltrans IQA reviews of the I-405 PSR.

Hawthorne

- Program \$600,000 in FY20 for MR312.81 - 120th St Improvements - Crenshaw Blvd to Felton Ave. The funds will be used to complete the Project Approval & Environmental Document (PA&ED), Plans Specification, and Estimates (PS&E) and Right of Way phases of the project.

Measure R NEXUS to Highway Operational Definition: This is an eligible Highway Operational Improvement which would create new turning movements on 120th Street reducing delays and enhancing traffic flow on this local collector street. The project includes turning lanes at 120th Street at Hawthorne Blvd, 120th Street at Prairie, 120th Street at I-105 Ramps, and 120th Street and Crenshaw Blvd.

Inglewood

- Deobligate \$384,000 from MR312.50 - ITS: Phase V Communication Gap Closure on Various Locations, ITS Upgrade and Arterial Detection. The City will use Prop C local return funds as the 20% matching funds requirement.

Lomita

- Program an additional \$79,000 in FY20 for MR312.43 - Intersection Improvements at PCH/Walnut St. & Western Ave/PV Drive North. The revised project budget is \$1,585,000. The additional funds are required due to redesign to accommodate additional Caltrans requirements that were requested during construction.

I-605 Corridor “Hot Spots” Interchanges

The Gateway Cities subregion had listed 42 projects to be funded by Measure R Highway Subregional Funds. Of those, 3 projects have been completed. The subregion has invested \$126 million of Measure R subregional highway funds. The 39 active projects are in planning, design, or construction phases. The update includes 4 new projects and funding adjustments to 7 existing projects as follows:

Metro

- Program an additional \$4,899,000 in FY21 for AE5204200 - I-605/SR-60 PAED. The revised

project budget is 38,899,000. The funds are being programmed to match the Board-approved contract amount.

- Program an additional \$8,026,000 in FY20 for AE33341001375 - I-605/I-5 PAED. The revised project budget is \$28,724,000. The funds are being programmed to match the Board-approved contract amount.
- Program \$20,000,000 over three fiscal years FY21, FY22, FY23 for MR315.02 - I-605 South St Improvements (Construction). The total construction budget is \$20,000,000. Plans, Specifications and Estimates are complete and funds are being programmed to commence the construction phase of the project.
- Program an additional \$4,506,000 in FY20 for MR315.37 - SR-91 Central to Acacia Improvements Project. The revised project budget is \$5,006,000. The funds are being programmed to match the Board-approved contract amount for the project.
- Program an additional \$150,000 in FY20 for MR315.63 - SR-60 at 7th Avenue Interchange Improvements. The revised project budget is \$2,250,000. The funds are being programmed to match the Board-approved contract amount for the project.
- Program an additional \$150,000 in FY20 for MR315.73 - I-605 Valley Blvd Interchange Improvements. The revised project budget is \$2,209,900. The funds are being programmed to match the Board-approved contract amount for the project.
- Program \$11,475,000 in FY20 for MR315.74 - WB SR-91 Alondra Blvd. to Shoemaker Ave. Improvement Project. The funds will be used to complete the Plans, Specifications, and Estimates and Right of Way phase of the project.
Measure R NEXUS to Highway Operational Definition: This project proposes modifications to SR-91 which will reduce congestion and improve freeway and local interchange operations. The improvements are eligible under Measure R Highway Operational Improvements.

Los Angeles County

- Program \$700,000 in FY21 for MR306.01 - Whittier Boulevard (Indiana Street to Paramount Boulevard) Corridor Project (Call Match - CFP F9304). The funds will be used to complete the Plans, Specifications, and Estimates (PS&E) and Construction phases of the Project. The project is located within the I-710 and SR-91/I-605/I-405 corridors, therefore the Measure R Local Match funds have been programmed to equally cost share expenditures between the I-710 and I-605 Hot Spots programs. This project had previously received Metro Board approval in January 2015 and was inadvertently removed from the project list.

Measure R NEXUS to Highway Operational Definition: The Project will provide operational improvements along the Whittier Boulevard Corridor between Indiana Street and Paramount Boulevard and will be implemented on 6.2 miles in the Cities of Pico Rivera, Montebello,

Commerce, and unincorporated areas of Los Angeles County. Proposed improvements include TSS, ITS improvements, equipment upgrades to detection systems and CCTV cameras, expansion to the ATMS, and communications to the IEN, all of which will reduce congestion and enhance traffic circulation. This project is eligible under Measure R Highway Operational Improvements.

Lakewood

- Program \$300,000 in FY20 for MR315.01 - Lakewood Boulevard at Hardwick Street Traffic Signal Improvements. The funds will be used to complete the Plans, Specifications, and Estimates (PS&E) and Construction phases of the Project.

Measure R NEXUS to Highway Operational Definition: The Project will provide traffic signal improvements at Lakewood Boulevard at Hardwick Street. Proposed improvements include a second northbound left turn lane at Lakewood Boulevard and Hardwick Street and traffic signal improvements. This project is an eligible Measure R Highway Operational Improvements.

Pico Rivera

- Deobligate \$456,250 from MR315.05 - Rosemead Blvd. & Beverly Blvd Interchange Improvements Project. The revised project budget is \$13,479,000. The project estimates for ROW have been reduced. Funds are being deobligated to match current project estimates.

I-710 South and/or Early Action Projects

The Gateway Cities subregion had listed 20 projects to be funded by Measure R Highway Subregional Funds. Of those, 4 projects have been completed. The subregion has invested \$125 million of Measure R subregional highway funds. The 13 active projects are in planning, design, or construction phases. The update includes 2 new projects and funding adjustments to 2 existing projects as follows:

Metro

- Program an additional \$7,975,000 in Prior Years for PS4340-1939 - I-710 Corridor Project (PA/ED). The revised project budget is \$40,495,931. The funds are being programmed to match the Metro board approved contract amount.
- Program an additional \$500,000 in FY 19-20 for MR306.02 - I-710 Soundwall Package 2, North of SR-91 to the SR-60. The total revised project budget is \$4,948,400. The funds will be used to complete the Right of Way (ROW) and Construction phase of the project. The ROW includes acquiring Temporary Construction Easements (TCE's) prior to the construction phase of the project. Including
- Program \$45,000,000 in FY 19-20, FY 20-21 and FY 21-22 for MR306.04 - I-710 Soundwall

Package 3, South of SR-91. The funds will be used to complete the Right of Way and Construction phase of the Project. The ROW includes acquiring Temporary Construction Easements (TCE's) prior to the construction phase of the project.

Measure R NEXUS to Highway Operational Definition: This is a soundwall project, an eligible highway operational improvement.

Los Angeles County

- Program \$300,000 in FY20 and \$400,000 in FY21 for MR306.01 - Whittier Boulevard (Indiana Street to Paramount Boulevard) Corridor Project (2015 Call Match - CFP F9304). The funds will be used to complete the Plans, Specifications, and Estimates (PS&E) and Construction phases of the Project. The project is located within both the I-710 and SR-91/I-605/I-405 corridors, therefore the Measure R Local Match funds have been programmed to equally cost share expenditures between the I-710 and I-605 Hot Spots programs. This project had previously received Metro board approval in January 2015 and was inadvertently removed from the project list.

Measure R NEXUS to Highway Operational Definition: The Project will provide operational improvements along the Whittier Boulevard Corridor between Indiana Street and Paramount Boulevard and will be implemented on 6.2 miles in the Cities of Pico Rivera, Montebello, Commerce, and unincorporated areas of Los Angeles County. Proposed improvements include TSS, ITS improvements, equipment upgrades to detection systems and CCTV cameras, expansion to the ATMS, and communications to the IEN, all of which will reduce congestion and enhance traffic circulation. This project is eligible under Measure R Highway Operational Improvements.

State Route 138 Capacity Enhancements

The North Los Angeles County subregion had listed 11 projects to be funded by Measure R Highway Subregional Funds. Of those, 1 project has been completed. The subregion has invested \$40 million of Measure R subregional highway funds. The 10 active projects are in planning, design, or construction phases. Metro Highway Program staff will work with the North County jurisdictions to fully fund their existing projects.

DETERMINATION OF SAFETY IMPACT

The recertification of the project list and funding allocations will have no adverse impact on the safety of Metro's patrons and employees and the users of the reference transportation facilities.

FINANCIAL IMPACT

Approval of Recommendation A will not require an FY20 Budget amendment at this time. Highway project management staff will monitor the respective projects and adjust funding as required to meet

project needs within the Adopted FY20 Highway budget. Funding for the projects is from the Measure R 20% Highway Capital Subfund earmarked for the subregions. FY20 funds are allocated for Arroyo Verdugo (Project No.460310), Las Virgenes Malibu (Project No. 460311), and South Bay (Project No. 460312) subregions in FY 20 budget. These three programs are budgeted under Cost Center 0042 in Account 54001 (Subsidies to Others).

The remaining funds are distributed from the Measure R 20% Highway Capital Subfund via funding agreements to Caltrans, and the cities of Palmdale and Lancaster under Cost Center 0442 in Project No. 460330, Account 54001 (Subsidies to Others).

Funding for the I-605 Corridor “Hot Spots” Projects, is allocated to Project No. 460314, Cost Centers 4720, 4730 & 0442, Account 54001 (Subsidies to Others) and account 50316 (Professional Services); 461314, Task 5.2.100; 462314, Task 5.2.100; 463314, Task 5.2.100; 460345, Task 5.2.100; 460346, Task 5.2.100; and for I-710 Early Action Projects, in Project No. 460316 in Cost Center 0442, Account 54001 (Subsidies to Others) and also under 462316, Task 5.2.100; 463316, Task 5.3.100; 463416, Task 5.3.100; and 463516, Task 5.3.100 in Account 50316 (Professional Services) in Cost Center 4720, are all included in the FY20 budget.

Moreover, programmed funds are based on estimated revenues. Since each MRHSP is a multi-year program with various projects, the Project Managers, the Cost Center Manager and the Senior Executive Officer, Program Management, Highway Program will be responsible for budgeting the costs in current and future years.

Impact to Budget

Upon Approval of recommendations, staff will rebalance the approved FY20 budgets to fund the identified priorities. Should additional funds be required for FY20 period, staff will revisit the budgetary needs using the quarterly and mid-year adjustment processes.

The source of funds for these projects is Measure R 20% Highway Funds. This fund source is not eligible for Bus and rail Operations or Capital expenses.

IMPLEMENTATION OF STRATEGIC PLAN GOALS

All projects listed in this update are consistent with the following goals of the Metro Vision 2028 Strategic Plan:

Goal 1: Provide high-quality mobility options that enable people to spend less time traveling by alleviating the current operational deficiencies and improving mobility along the highways.

Goal 4: Transform LA county through regional collaboration by partnering with the various Subregions to identify the needed improvements and take the lead in development and implementation of their projects.

ALTERNATIVES CONSIDERED

The Board may choose to not approve the revised project lists and funding allocation. However, this option is not recommended as all projects are consistent with the Board's policies and Measure R Guidelines supporting improved mobility in Los Angeles County.

NEXT STEPS

Metro Highway Program Staff will continue to work with the subregions to identify and deliver projects. Program/ Project updates will be provided to the Board on a semi-annual and as-needed basis.

ATTACHMENT

Attachment A - Projects Receiving Measure R Funds

Prepared by: Isidro Panuco, Sr. Mgr. Transportation Planning, (213) 418-3208
Abdollah Ansari, Sr. Executive Officer, (213) 922-4781

Reviewed by: Richard F. Clarke, Chief Program Management Officer, (213) 922-7557

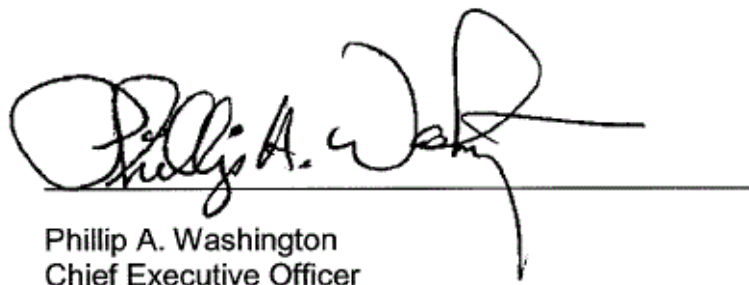

Phillip A. Washington
Chief Executive Officer

ATTACHMENT A

Measure R Highway Operational Improvements Projects											
<i>(Dollars in Thousands)</i>											
HIGHWAY OPS IMP GRAND TOTAL				1,085,319	109,537	1,184,855	949,419	139,269	44,307	1,695	6,800
Lead Agency	Fund Agr (FA) No.	PROJECT/LOCATION	Notes	Prior Alloc	Alloc Change	Current Alloc	Prior Yr Program	FY20	FY21	FY22	FY23
Arroyo Verdugo Operational Improvements				85,338.4	5,700.0	91,038.4	61,624.4	10,750.0	13,999.0	2,865.0	1,800.0
Burbank	MR310.06	San Fernando Blvd. / Burbank Blvd. Intersection		2,325.0	0.0	2,325.0	2,325.0				
Burbank	MR310.07	Widen Magnolia Blvd / I-5 Bridge for center-turn lane		3,967.0	0.0	3,967.0	250.0		3,717.0		
Burbank	MR310.08	I-5 Corridor Arterial Signal Improvements (Completed)		2,600.0	0.0	2,600.0	2,600.0				
Burbank	MR310.09	SR-134 Corridor Arterial Signal Improvements (Completed)		2,975.0	0.0	2,975.0	2,975.0				
Burbank	MR310.10	Widen Olive Ave / I-5 Bridge for center-turn lane		3,897.0	0.0	3,897.0	250		3,647.0		
Burbank	MR310.11	Olive Ave. / Verdugo Ave. Intersection Improvement		3,600.0	0.0	3,600.0	1,600.0	2,000.0			
Burbank	MR310.23	Chandler Bikeway Extension (call match) F7506		659.8	(0.0)	659.8	659.8				
Burbank	MR310.31	SR-134 Corridor Arterial Signal Improvements - Phase 2		2,000.0	0.0	2,000.0	2,000.0				
Burbank	MR310.33	Media District Traffic Signal Improvments		1,400.0	0.0	1,400.0	1,400.0				
Burbank	MR310.38	I-5 Corridor Arterial Signal Improvements - Phase 2		1,150.0	0.0	1,150.0	1,150.0				
Burbank	MR310.46	Glenoaks Blvd Arterial and First St Signal Improvements		3,200.0	0.0	3,200.0	1,900.0	1,300.0			
Burbank	MR310.50	I-5 Downtown Soundwall Project - Orange Grove Ave to Magnolia		1,000.0	0.0	1,000.0	1,000.0				
Burbank	MR310.51	Alameda Ave Signal Synchronization Glenoaks Blvd to Riverside Dr.		250.0	0.0	250.0		250.0			
Burbank	MR310.55	I-5 Corridor Arterial Signal Improvements - Phase 3	Add	0.0	1,400.0	1,400.0			200.0	1,200.0	
Burbank	MR310.56	Victory Blvd and Buena Vista St Signal Synchronization	Add	0.0	250.0	250.0			250.0		
Burbank	MR310.57	Olive Ave and Glenoaks Blvd Signal Synchronization	Add	0.0	350.0	350.0				350.0	
Burbank	MR310.58	Downtown Burbank Signal Synchronization	Add	0.0	250.0	250.0					250.0
Burbank	MR310.59	Burbank LA River Bicycle Bridge at Bob Hope Drive	Add	0.0	2,000.0	2,000.0		500.0	1,500.0		
TOTAL BURBANK				29,023.8	4,250.0	33,273.8	18,109.8	4,050.0	9,314.0	1,550.0	250.0

ATTACHMENT A

Lead Agency	Fund Agr (FA) No.	PROJECT/LOCATION	Notes	Prior Alloc	Alloc Change	Current Alloc	Prior Yr Program	FY20	FY21	FY22	FY23
Glendale	MR310.01	Fairmont Ave. Grade Separation at San Fernando Rd. (Construction) (Completed)		1,658.7	0.0	1,658.7	1,658.7				
Glendale	MR310.02	Fairmont Ave. Grade Sep. at San Fernando -- Design (FA canceled and funds previously moved to MR310.01)		0.0	0.0	0.0	0.0				
Glendale	MR310.04	San Fernando/Grandview At-Grade Rail Crossing Imp. (Completed)		1,850.0	0.0	1,850.0	1,850.0				
Glendale	MR310.05	Central Ave Improvements / Broadway to SR-134 EB Offramp (Completed)		3,250.0	0.0	3,250.0	3,250.0				
Glendale	MR310.13	Glendale Narrows Bikeway Culvert		1,246.5	0.0	1,246.5	1,246.5				
Glendale	MR310.14	Verdugo Road Signal Upgrades (Completed)		557.0	0.0	557.0	557.0				
Glendale	MR310.16	SR-134 / Glendale Ave. Interchange Modification (Completed)		1,585.5	0.0	1,585.5	1,585.5				
Glendale	MR310.17	Ocean View Blvd. Traffic Signals Installation and Modification (Completed)		1,000.0	0.0	1,000.0	1,000.0				
Glendale	MR310.18	Sonora Avenue At-Grade Rail Crossing Safety Upgrade (Completed)		2,700.0	0.0	2,700.0	2,700.0				
Glendale	MR310.19	Traffic Signal Sync Brand / Colorado-San Fernando / Glendale-Verdugo (Completed)		340.9	0.0	340.9	340.9				
Glendale	MR310.20	Verdugo Rd / Honolulu Ave / Verdugo Blvd Intersection Modification (Completed)		397.3	0.0	397.3	397.3				
Glendale	MR310.21	Colorado St. Widening between Brand Blvd. and East of Brand Blvd. (Completed)		350.0	0.0	350.0	350.0				
Glendale	MR310.22	Glendale Narrows Riverwalk Bridge		600.0	0.0	600.0	600.0				

ATTACHMENT A

Lead Agency	Fund Agr (FA) No.	PROJECT/LOCATION	Notes	Prior Alloc	Alloc Change	Current Alloc	Prior Yr Program	FY20	FY21	FY22	FY23
Glendale	MR310.24	Construction of Bicycle Facilities		244.3	0.0	244.3	244.3				
Glendale	MR310.25	210 Soundwalls Project		4,520.0	0.0	4,520.0	1,520.0		3,000.0		
Glendale	MR310.26	Bicycle Facilities, Phase 2 (Class III Bike Routes)		225.0	0.0	225.0	225.0				
Glendale	MR310.28	Pennsylvania Ave Signal at I-210 On/Off-Ramps		500.0	0.0	500.0	500.0				
Glendale	MR310.32	Regional Arterial Performance Measures (Call Match) F7321		100.0	0.0	100.0	100.0				
Glendale	MR310.34	Regional Bike Stations (Call Match) F7709		332.2	0.0	332.2	332.2				
Glendale	MR310.36	Signalizations of SR-2 Fwy Ramps @ Holly	Chg	600.0	0.0	600.0	0.0			100.0	500.0
Glendale	MR310.35	Signal Installations at Various Locations (Completed)		1,500.0	0.0	1,500.0	1,500.0				
Glendale	MR310.37	Verdugo Boulevard Traffic Signal Modification at Vahili Way and SR-2	Chg	1,100.0	350.0	1,450.0	1,100.0	350.0			
Glendale	MR310.39	Widening of SR-2 Fwy Ramps @ Mountain	Chg	1,200.0	0.0	1,200.0	0.0			150.0	1,050.0
Glendale	MR310.40	Pacific Ave: Colorado to Glenoaks & Burchett St: Pacific To Central Street Improvements (Completed)		3,315.0	0.0	3,315.0	3,315.0				
Glendale	MR310.41	Doran St. (From Brand Blvd. to Adams St.)		1,450.0	0.0	1,450.0	1,450.0				
Glendale	MR310.42	Arden Ave. (From Highland Ave. to Kenilworth St.) (Completed)		623.2	0.0	623.2	623.2				
Glendale	MR310.43	Verdugo Rd. Street Improvements Project (Traffic Signal Modification)	Chg	1,650.0	0.0	1,650.0	0.0		585.0	1,065.0	
Glendale	MR310.47	Traffic Signals on Glenwood Rd. and Modificaitons on La Crescenta and Central Ave.		2,025.0	0.0	2,025.0	2,025.0				
Glendale	MR310.48	San Frenando Rd and Los Angeles Street Traffic Signal Installation & Intersection Modification		400.0	0.0	400.0	400.0				
Glendale	MR310.49	Traffic Signal Modification & Upgrades on Honolulu Ave		3,000.0	0.0	3,000.0	1,800.0	1,200.0			
Glendale	MR310.52	Traffic Signal Improvements at Chevy Chase Dr/California Ave/		2,500.0	0.0	2,500.0	1,000.0	1,500.0			
Glendale	MR310.54	Traffic Signal Modification on La Crescenta Ave and San Fernando Rd		1,650.0	0.0	1,650.0		1,650.0			
Glendale	MR310.60	N. Verdugo Rd Traffic Signal Modifications (from Glendale Community College to Menlo Dr at Canada Blvd)	Add	0.0	1,100.0	1,100.0			1,100.0		
		TOTAL GLENDALE		42,470.6	1,450.0	43,920.6	31,670.6	4,700.0	4,685.0	1,315.0	1,550.0

ATTACHMENT A

Lead Agency	Fund Agr (FA) No.	PROJECT/LOCATION	Notes	Prior Alloc	Alloc Change	Current Alloc	Prior Yr Program	FY20	FY21	FY22	FY23
La Canada Flintridge	MR310.03	Soundwalls on Interstate I-210 (Completed)		4,588.0	0.0	4,588.0	4,588.0				
La Canada Flintridge	MR310.45	Soundwalls on Interstate I-210 in La Canada-Flintridge (phase 2)		1,800.0	0.0	1,800.0	1,800.0				
La Canada Flintridge	MR310.53	Soundwall on I-210 (Phase 3)		3,712.0	0.0	3,712.0	1,712.0	2,000.0			
		TOTAL LA CANADA FLINTRIDGE		10,100.0	0.0	10,100.0	8,100.0	2,000.0	0.0	0.0	0.0
LA County	MR310.44	Soudwalls on Interstate I-210 in LA Crescenta-Montrose		3,044.0	0.0	3,044.0	3,044.0				
		TOTAL LA COUNTY		3,044.0	0.0	3,044.0	3,044.0	0.0	0.0	0.0	0.0
Metro/Caltrans	MR310.29	NBSSR on I-210 frm Pennsylvania Ave. to West of SR-2		700.0	0.0	700.0	700.0				
		TOTAL METRO		700.0	0.0	700.0	700.0	0.0	0.0	0.0	0.0
		TOTAL ARROYO VERDUGO OPS IMPS		85,338.4	5,700.0	91,038.4	61,624.4	10,750.0	13,999.0	2,865.0	1,800.0

ATTACHMENT A

Lead Agency	Fund Agr (FA) No.	PROJECT/LOCATION	Notes	Prior Alloc	Alloc Change	Current Alloc	Prior Yr Program	FY20	FY21	FY22	FY23
Las Virgenes/Malibu Operational Improvements				156,651.0	0.0	156,651.0	154,901.0	1,750.0	0.0	0.0	0.0
Westlake Village	MR311.01	Lindero Canyon Road Interchange, Phase 3A Design		443.7	0.0	443.7	443.7				
Westlake Village	MR311.02	Highway 101 Park and Ride Lot (Design Completed)		243.7	0.0	243.7	243.7				
Westlake Village	MR311.10	Rte 101/ Lindero Cyn. Rd. Interchange Improvements, Phase 3B,4B Construction (Completed)		3,251.0	0.0	3,251.0	3,251.0				
Westlake Village	MR311.18	Rte 101/ Lindero Cyn. Rd. Interchange Improvements, Phase 3A Construction		9,419.0	0.0	9,419.0	9,419.0				
Westlake Village	MR311.19	Highway 101 Park and Ride Lot (Completed)		4,943.6	0.0	4,943.6	4,943.6				
TOTAL WESTLAKE VILLAGE				18,301.0	0.0	18,301.0	18,301.0	0.0	0.0	0.0	0.0
Agoura Hills	MR311.03	Palo Comado Interchange	Deob	11,000.0	(550.0)	10,450.0	10,450.0				
Agoura Hills	MR311.04	Aguora Road/Kanan Road Intersection Improvements	Chg	800.0	350.0	1,150.0	800.0	350.0			
Agoura Hills	MR311.05	Agoura Road Widening	Chg	36,500.0	200.0	36,700.0	36,500.0	200.0			
Agoura Hills	MR311.14	Kanan Road Corridor from Thousand Oaks Blvd to Cornell Road PSR		700.0	0.0	700.0	700.0				
Agoura Hills	MR311.15	Agoura Hills Multi-Modal Center		100.0	0.0	100.0	100.0				
TOTAL AGOURA HILLS				49,100.0	0.0	49,100.0	48,550.0	550.0	0.0	0.0	0.0
Calabasas	MR311.06	Lost Hills Overpass and Interchange		35,500.0	0.0	35,500.0	35,500.0				
Calabasas	MR311.07	Mulholland Highway Scenic Corridor Completion (Completed)		4,389.8	0.0	4,389.8	4,389.8				
Calabasas	MR311.08	Las Virgenes Scenic Corridor Widening (Completed)		5,746.2	0.0	5,746.2	5,746.2				
Calabasas	MR311.09	Parkway Calabasas/US 101 SB Offramp (Completed)		214.0	0.0	214.0	214.0				
Calabasas	MR311.20	Off-Ramp for US 101 at Las Virgenes Road (Cancelled)		0.0	0.0	0.0	0.0				
Calabasas	MR311.33	Park and Ride Lot on or about 23577 Calabasas Road (near Route 101) (Completed)		3,700.0	0.0	3,700.0	3,700.0				
TOTAL CALABASAS				49,550.0	0.0	49,550.0	49,550.0	0.0	0.0	0.0	0.0

ATTACHMENT A

Lead Agency	Fund Agr (FA) No.	PROJECT/LOCATION	Notes	Prior Alloc	Alloc Change	Current Alloc	Prior Yr Program	FY20	FY21	FY22	FY23
Malibu	MR311.24	Malibu/Civic Center Way Widening		5,200.0	0.0	5,200.0	4,000.0	1,200.0			
Malibu	MR311.26	PCH-Raised Median and Channelization from Webb Way to Corral Canyon Road		6,950.0	0.0	6,950.0	6,950.0				
Malibu	MR311.27	PCH Intersections Improvements		1,000.0	0.0	1,000.0	1,000.0				
Malibu	MR311.28	Kanan Dume Road Arrestor Bed Improvements and Intersection with PCH Construction (Completed)		900.0	0.0	900.0	900.0				
Malibu	MR311.29	PCH Regional Traffic Message System (CMS)		1,300.0	0.0	1,300.0	1,300.0				
Malibu	MR311.30	PCH Roadway and Bike Route Improvements fr. Busch Dr. to Western City Limits (Completed)		500.0	0.0	500.0	500.0				
Malibu	MR311.32	PCH and Big Rock Dr. Intersection and at La Costa Area Pedestrian Improvements		950.0	0.0	950.0	950.0				
Malibu	MR311.35	Park and Ride Lot on Civic Center Way and/or PCH		3,500.0	0.0	3,500.0	3,500.0				
Malibu	MR311.11	PCH Signal System Improvements from John Tyler Drive to Topanga Canyon Blvd		13,700.0	0.0	13,700.0	13,700.0				
		TOTAL MALIBU		34,000.0	0.0	34,000.0	32,800.0	1,200.0	0.0	0.0	0.0
Hidden Hills	MR311.34	Long Valley Road/Valley Circle/US-101 On-Ramp Improvements		5,700.0	0.0	5,700.0	5,700.0				
		TOTAL HIDDEN HILLS		5,700.0	0.0	5,700.0	5,700.0	0.0	0.0	0.0	0.0
		TOTAL LAS VIRGENES/MALIBU OPS IMPS		156,651.0	0.0	156,651.0	154,901.0	1,750.0	0.0	0.0	0.0

ATTACHMENT A

Lead Agency	Fund Agr (FA) No.	PROJECT/LOCATION	Notes	Prior Alloc	Alloc Change	Current Alloc	Prior Yr Program	FY20	FY21	FY22	FY23
South Bay I-405, I-110, I-105, & SR-91 Ramp / Interchange Imps				236,605.9	1,602.0	238,207.9	208,308.9	23,440.0	4,764.0	1,695.0	0.0
SBCCOG	MR312.01	South Bay Cities CCGT Program Development & Oversight and Program Administration (Project Development Budget Included)		13,375.0	0.0	13,375.0	12,758.0	617.0			
		TOTAL SBCCOG		13,375.0	0.0	13,375.0	12,758.0	617.0	0.0	0.0	0.0
Caltrans	MR312.11	ITS: I-405, I-110, I-105, SR-91 at Freeway Ramp/Arterial Signalized Intersections		5,357.0	(0.0)	5,357.0	5,357.0				
Caltrans	MR312.24	I-110 Aux lane from SR-91 to Torrance Blvd Aux lane & I-405/I-110 Connector (Completed)		8,120.0	0.0	8,120.0	8,120.0				
Caltrans	MR312.25	I-405 at 182nd St. / Crenshaw Blvd Improvements		24,400.0	0.0	24,400.0	17,800.0	6,600.0			
Caltrans	MR312.29	ITS: Pacific Coast Highway and Parallel Arterials From I-105 to I-110		9,000.0	0.0	9,000.0	9,000.0				
Caltrans	MR312.45	PAED Integrated Corridor Management System (ICMS) on I-110 from Artesia Blvd and I-405		1,000.0	0.0	1,000.0	1,000.0				
Caltrans	MR312.77	I-405 IQA Review for PSR (El Segundo to Artesia Blvd) (Completed)		150.0	0.0	150.0	150.0				
Caltrans	MR312.78	I-405 IQA Review for PSR (Main St to Wilmington)	Chg	80.0	70.0	150.0	80.0	70.0			
		TOTAL CALTRANS		48,107.0	70.0	48,177.0	41,507.0	6,670.0	0.0	0.0	0.0
Carson/Metro	MR312.46	Upgrade Traffic Control Signals at the Intersection of Figueroa St and 234th St. and Figueroa and 228th st.		150.0	0.0	150.0	150.0				
Carson/Metro	MR312.41	Traffic Signal Upgrades at 10 Intersections		1,400.0	0.0	1,400.0	1,400.0				
Carson	MR312.80	223rd st Widening		1,000.0	0.0	1,000.0		1,000.0			
		TOTAL CARSON		2,550.0	0.0	2,550.0	1,550.0	1,000.0	0.0	0.0	0.0
El Segundo	MR312.22	Maple Ave Improvements from Sepulveda Blvd to Parkview Ave. (Completed)		2,500.0	0.0	2,500.0	2,500.0				
El Segundo	MR312.27	PCH Improvements from Imperial Highway to El Segundo Boulevard		400.0	0.0	400.0	400.0				
El Segundo	MR312.57	Park Place Roadway Extension and Railroad Grade Separation Project		350.0	0.0	350.0	350.0				
		TOTAL EL SEGUNDO		3,250.0	0.0	3,250.0	3,250.0	0.0	0.0	0.0	0.0

ATTACHMENT A

Lead Agency	Fund Agr (FA) No.	PROJECT/LOCATION	Notes	Prior Alloc	Alloc Change	Current Alloc	Prior Yr Program	FY20	FY21	FY22	FY23
Gardena	MR312.17	Rosecrans Ave Improvements from Vermont Ave to Crenshaw Blvd (Completed)		4,967.0	0.0	4,967.0	4,967.0				
Gardena	MR312.19	Artesia Blvd at Western Ave Intersection Improvements (Westbound left turn lanes) (Completed)		393.0	0.0	393.0	393.0				
Gardena	MR312.21	Vermont Ave Improvements from Rosecrans Ave to 182nd Street (Completed)		2,090.3	0.0	2,090.3	2,090.3				
Gardena	MR312.02	Traffic Signal Reconstruction on Vermont at Redondo Beach Blvd and at Rosecrans Ave.		1,500.0	0.0	1,500.0	1,500.0				
Gardena	MR312.09	Artesia Blvd Arterial Improvements from Western Ave to Vermont Ave		2,523.0	0.0	2,523.0	2,523.0				
Gardena	MR312.79	Traffic Signal Install at Vermont Ave. and Magnolia Ave		144.0	0.0	144.0		144.0			
		TOTAL GARDENA		11,617.3	0.0	11,617.3	11,473.3	144.0	0.0	0.0	0.0
Hawthorne	MR312.03	Rosecrans Ave Widening from I-405 SB off ramp to Isis Ave (Completed)		2,100.0	0.0	2,100.0	2,100.0				
Hawthorne	MR312.33	Aviation Blvd at Marine Ave Intersection Improvements (Westbound right turn lane) (Completed)		3,600.0	0.0	3,600.0	3,600.0				
Hawthorne	MR312.44	Hawthorne Blvd Improvements from El Segundo Blvd to Rosecrans Ave (Completed)		7,551.0	0.0	7,551.0	7,551.0				
Hawthorne	MR312.47	Signal Improvements on Prairie Ave from 118th St. to Marine Ave.		1,237.0	0.0	1,237.0	1,237.0				
Hawthorne	MR312.54	Intersection widening & Traffic Signal modifications on Inglewood Ave at El Segundo Blvd; on Crenshaw Blvd At Becket Road on Crenshaw at Jack Nathan and on 120th St		2,000.0	0.0	2,000.0	2,000.0				
Hawthorne	MR312.61	Hawthorne Blvd Arterial Improvements, from 126th St to 111th St.		4,400.0	1,237.0	5,637.0	5,637.0				
Hawthorne	MR312.66	Imperial Ave Signal Improvements and Intersection Capacity Project		1,995.0	0.0	1,995.0	200.0	700.0	600.0	495.0	
Hawthorne	MR312.67	Rosecrans Ave Signal Improvements and Intersection Capacity Enhancements.		3,200.0	0.0	3,200.0	500.0	1,000.0	1,200.0	500.0	
Hawthorne	MR312.68	El Segundo Blvd Improvements Project Phase I		2,000.0	0.0	2,000.0	400.0	400.0	500.0	700.0	
Hawthorne	MR312.69	El Segundo Blvd Improvements Project Phase II		600.0	0.0	600.0	100.0	300.0	200.0		
Hawthorne	MR312.81	120th St Improvements -- Crenshaw Blvd to Felton Ave	Add	0.0	600.0	600.0	0.0	600.0			
		TOTAL HAWTHORNE		28,683.0	1,837.0	30,520.0	23,325.0	3,000.0	2,500.0	0.0	0.0

ATTACHMENT A

Lead Agency	Fund Agr (FA) No.	PROJECT/LOCATION	Notes	Prior Alloc	Alloc Change	Current Alloc	Prior Yr Program	FY20	FY21	FY22	FY23
Hermosa Beach	MR312.05	PCH (SR-1/PCH) Improvements between Anita St. and Artesia Boulevard		574.7	0.0	574.7	574.7				
		TOTAL HERMOSA BEACH		574.7	0.0	574.7	574.7	0.0	0.0	0.0	0.0
Inglewood	MR312.12	Intelligent Transportation System (ITS) Phase IV		3,500.0	0.0	3,500.0	3,500.0				
Inglewood	MR312.50	ITS: Phase V - Communication Gap Closure on Various Locations, ITS Upgrade and Arterial Detection	Deob	384.0	(384.0)	0.0					
Inglewood	MR312.70	Prairie Ave Signal Synchronization Project		205.0	0.0	205.0	205.0				
Inglewood	MR312.71	La Cienega Blvd Synchronization Project		80.0	0.0	80.0	80.0				
Inglewood	MR312.72	Arbor Vitae Synchronization Project		130.0	0.0	130.0	130.0				
Inglewood	MR312.73	Florence Ave Synchronization Project		255.0	0.0	255.0	255.0				
		TOTAL INGLEWOOD		4,554.0	(384.0)	4,170.0	4,170.0	0.0	0.0	0.0	0.0
LA City	MR312.56	Del Amo Blvd Improvements from Western Ave to Vermont Ave Project Oversight		100.0	0.0	100.0	100.0				
LA City	MR312.51	Improve Anaheim St. from Farragut Ave. to Dominguez Channel (Call Match) F7207		1,313.0	(0.0)	1,313.0	1,313.0				
LA City	MR312.48	Alameda St. (South) Widening frm. Anaheim St. to Harry Bridges Blvd		2,875.0	0.0	2,875.0	2,875.0				
LA City	MR312.74	Alameda St. (East) Widening Project		3,580.0	0.0	3,580.0	1,000.0	1,000.0	1,580.0		
		TOTAL LA CITY		7,868.0	(0.0)	7,868.0	5,288.0	1,000.0	1,580.0	0.0	0.0
LA County	MR312.16	Del Amo Blvd improvements from Western Ave to Vermont Ave (Completed)		307.0	0.0	307.0	307.0				
LA County	MR312.52	ITS: Improvements on South Bay Arterials (Call Match) F7310		1,021.0	0.0	1,021.0	1,021.0				
LA County	MR312.64	South Bay Arterial System Detection Project		2,000.0	0.0	2,000.0	2,000.0				
		TOTAL LA COUNTY		3,328.0	0.0	3,328.0	3,328.0	0.0	0.0	0.0	0.0
Lawndale	MR312.15	Inglewood Ave Widening from 156th Street to I-405 Southbound on-ramp (Completed)		43.0	0.0	43.0	43.0				
Lawndale	MR312.36	ITS: City of Lawndale Citywide Improvements (Completed)		878.3	0.0	878.3	878.3				
Lawndale	MR312.49	Redondo Beach Blvd Mobility Improvements from Prairie to Artesia (Call Match) F9101		1,039.3	0.0	1,039.3	1,039.3				
Lawndale	MR312.31	Manhattan Bch Blvd at Hawthorne Blvd Left Turn Signal Improvements		508.0	0.0	508.0	508.0				
		TOTAL LAWDALE		2,468.6	0.0	2,468.6	2,468.6	0.0	0.0	0.0	0.0

ATTACHMENT A

Lead Agency	Fund Agr (FA) No.	PROJECT/LOCATION	Notes	Prior Alloc	Alloc Change	Current Alloc	Prior Yr Program	FY20	FY21	FY22	FY23
Lomita	MR312.43	Intersection Improvements at Western/Palos Verdes Dr and PCH/Walnut	chg	1,506.0	79.0	1,585.0	1,506.0	79.0			
		TOTAL LOMITA		1,506.0	79.0	1,585.0	1,506.0	79.0	0.0	0.0	0.0
Manhattan Beach	MR312.04	Sepulveda Blvd at Marine Ave Intersection Improvements (West Bound left turn lanes) (Completed)		346.5	0.0	346.5	346.5				
Manhattan Beach	MR312.28	Seismic retrofit of widened Bridge 53-62 from Sepulveda Blvd from 33rd Street to south of Rosecrans Ave		9,100.0	0.0	9,100.0	9,100.0				
Manhattan Beach	MR312.34	Aviation Blvd at Artesia Blvd Intersection Improvements (Southbound right turn lane)		1,500.0	0.0	1,500.0	1,500.0				
Manhattan Beach	MR312.35	Sepulveda Blvd at Manhattan Beach Blvd Intersection Improvements (NB, WB, EB left turn lanes and SB right turn lane)		980.0	0.0	980.0	980.0				
Manhattan Beach	MR312.62	Sepulveda Blvd Operational Improvements at Rosecrans Ave, 33rd St, Cedar Ave, 14th St and 2nd St.		900.0	0.0	900.0	900.0				
		TOTAL MANHATTAN BEACH		12,826.5	0.0	12,826.5	12,826.5	0.0	0.0	0.0	0.0
Metro	MR312.55	I-405 Improvements from I-110 to Wilmington (Completed)		4,200.0	0.0	4,200.0	600.0	3,600.0			
Metro	MR312.30	I-405 Improvements from I-105 to Artesia Blvd		4,181.0	0.0	4,181.0	881.0	3,300.0			
Metro	0000020337-4010-2540-01-40	South Bay Arterial Baseline Conditions Analysis (Completed)		250.0	0.0	250.0	250.0				
Metro	TBD	Inglewood Transit Center at Florence/La Brea		1,500.0	0.0	1,500.0	1,500.0				
		TOTAL METRO		10,131.0	0.0	10,131.0	3,231.0	6,900.0	0.0	0.0	0.0
Rancho Palos Verdes	MR312.39	Western Ave. (SR-213) from Palos Verdes Drive North to 25th street -- PSR		90.0	0.0	90.0	90.0				
		TOTAL RANCHO PALOS VERDES		90.0	0.0	90.0	90.0	0.0	0.0	0.0	0.0
POLA	MR312.32	SR-47/Vincent Thomas Bridge on/off ramp Improvements at Harbor Blvd		3,830.0	0.0	3,830.0	1,600.0	2,230.0			
		PORT OF LOS ANGELES		3,830.0	0.0	3,830.0	1,600.0	2,230.0	0.0	0.0	0.0

ATTACHMENT A

Lead Agency	Fund Agr (FA) No.	PROJECT/LOCATION	Notes	Prior Alloc	Alloc Change	Current Alloc	Prior Yr Program	FY20	FY21	FY22	FY23
Redondo Beach	MR312.06	Pacific Coast Highway improvements from Anita Street to Palos Verdes Blvd		1,400.0	0.0	1,400.0	1,400.0				
Redondo Beach	MR312.07	Pacific Coast Highway at Torrance Blvd intersection improvements (Northbound right turn lane)		936.0	0.0	936.0	936.0				
Redondo Beach	MR312.08	Pacific Coast Highway at Palos Verdes Blvd intersection improvements (WB right turn lane) (Completed)		389.0	0.0	389.0	389.0				
Redondo Beach	MR312.13	Aviation Blvd at Artesia Blvd intersection improvements (Completed) (Eastbound right turn lane)		22.0	0.0	22.0	22.0				
Redondo Beach	MR312.14	Inglewood Ave at Manhattan Beach Blvd intersection improvements (Eastbound right turn lane) (Completed)		30.0	0.0	30.0	30.0				
Redondo Beach	MR312.20	Aviation Blvd at Artesia Blvd intersection improvements (Northbound right turn lane)		847.0	0.0	847.0	847.0				
Redondo Beach	MR312.42	Inglewood Ave at Manhattan Beach Blvd intersection improvements (Southbound right turn lane)		5,175.0	0.0	5,175.0	5,175.0				
Redondo Beach	MR312.75	Kingsdale Ave at Artesia Blvd Intersection Improvements		992.0	0.0	992.0	992.0				
Redondo Beach	MR312.38	PCH at Anita St Improv (left and right turn lane)		300.0	0.0	300.0		300.0			
		TOTAL REDONDO BEACH		10,091.0	0.0	10,091.0	9,791.0	300.0	0.0	0.0	0.0
Torrance	MR312.10	Pacific Coast Highway at Hawthorne Blvd intersection improvements		19,600.0	0.0	19,600.0	19,600.0				
Torrance	MR312.18	Maple Ave at Sepulveda Blvd Intersection Improvements (Completed) (Southbound right turn lane)		319.9	0.0	319.9	319.9				
Torrance	MR312.23	Torrance Transit Park and Ride Regional Terminal Project 465 Crenshaw Blvd		25,700.0	0.0	25,700.0	25,700.0				
Torrance	MR312.26	I-405 at 182nd St. / Crenshaw Blvd Operational Improvements		15,300.0	0.0	15,300.0	15,300.0				
Torrance	MR312.40	Pacific Coast Highway at Vista Montana/Anza Ave Intersection Improvements		2,900.0	0.0	2,900.0	2,900.0				
Torrance	MR312.58	Pacific Coast Highway from Calle Mayor to Janet Lane Safety Improvements		852.0	0.0	852.0	852.0				
Torrance	MR312.59	Pacific Coast Highway at Madison Ave Signal upgrades to provide left-turn phasing (Completed)		500.0	0.0	500.0	500.0				
Torrance	MR312.60	Crenshaw from Del Amo to Dominguez - 3 SB turn lanes at Del Amo Blvd, 208th St., Transit Center Entrance, Signal improvements at 2 new signal at Transit Center		3,300.0	0.0	3,300.0	3,300.0				
Torrance	MR312.76	Plaza Del Amo at Western Ave (SR-213) Improvements		2,784.0	0.0	2,784.0	1,100.0	1,000.0	684.0		
Torrance	MR312.63	PCH at Crenshaw Blvd Intersection Imp		500.0	0.0	500.0		500.0			
		TOTAL TORRANCE		71,755.9	0.0	71,755.9	69,571.9	1,500.0	684.0	0.0	0.0
		TOTAL SOUTH BAY		236,605.9	1,602.0	238,207.9	208,308.9	23,440.0	4,764.0	1,695.0	0.0

ATTACHMENT A

Lead Agency	Fund Agr (FA) No.	PROJECT/LOCATION	Notes	Prior Alloc	Alloc Change	Current Alloc	Prior Yr Program	FY20	FY21	FY22	FY23
Gateway Cities: I-605/SR-91/I-405 Corridors "Hot Spots"				213,708.4	48,059.7	261,768.2	198,373.2	36,881.9	11,513.1	10,000.0	5,000.0
GCCOG	MOU.306.03	GCCOG Engineering Support Services		1,550.0	0.0	1,550.0	1,100.0	450.0			
GCCOG	MR315.29	Gateway Cities Third Party Support		100.0	0.0	100.0	100.0				
TOTAL GCCOG				1,650.0	0.0	1,650.0	1,200.0	450.0	0.0	0.0	0.0
Metro	PS4720-3334	Program/Project Management Support of Measure R Funds		200.0	0.0	200.0	200.0				
Metro	PS4720-3252	I-605 Arterial Hot Spots in the City of Whittier: PAED for Santa Fe Springs/ Whittier, Painter/Whittier, & Colima Whittier Intersection Improvements (Completed)		680.0	0.0	680.0	680.0				
Metro	PS4720-3250	Arterial Hot Spots in the Cities of Long Beach, Bellflower, and Paramount: PAED for Lakewood/Alondra, Lakewood/Spring, and Bellflower Spring Intersection & PS&E for Lakewood/Alondra Intersection Improvements Improvements (Completed)		572.7	0.0	572.7	572.7				
Metro	PS4720-3251	Arterial Hot Spots in the Cities of Cerritos, La Mirada, and Santa Fe Springs: PAED for Valley View/Rosecrans, Valley View/Alondra, Carmenita/South, and Bloomfield/Artesia Intersection Improvements (Completed)		560.7	0.0	560.7	560.7				
Metro	AE25081	Arterial Hot Spots in the Cities of Cerritos: PS&E for Carmenita/South and Bloomfield/Artesia Intersection Improvements (Completed)		100.0	0.0	100.0	100.0				
Metro	AE25083	Arterial Hot Spots in the Cities of La Mirada and Santa Fe Springs: PS&E for Valley View/Rosecrans and Valley View/Alondra Intersection Improvements (Completed)		100.0	0.0	100.0	100.0				
Metro	PS4603-2582	Professional Services for I-605 Feasibility Study (Completed)		6,170.0	0.0	6,170.0	6,170.0				
Metro	PS4603-2582	Professional Services for PSR/PDS: I-5/I-605 and I-605/SR-91 (Completed)		3,121.0	0.0	3,121.0	3,121.0				
Metro	PS4720-3235	Professional Services for 605/60 PSR/PDS		3,040.0	0.0	3,040.0	3,040.0				

ATTACHMENT A

Lead Agency	Fund Agr (FA) No.	PROJECT/LOCATION	Notes	Prior Alloc	Alloc Change	Current Alloc	Prior Yr Program	FY20	FY21	FY22	FY23
Metro	AE5204200	Professional Services for 605/60 PA/ED	Chg	34,000.0	4,899.0	38,899.0	26,000.0	8,000.0	4,899.0		
Metro	PS47203004	Professional Services for the Gateway Cities Strategic Transportation Plan		10,429.5	(0.0)	10,429.5	10,429.5				
Metro	AE333410011375	Professional Services for the I-605/I-5 PA/ED	Chg	20,698.0	8,026.0	28,724.0	20,698.0	8,026.0			
Metro	AE476110012334	Professional Services for WB SR-91 Improvements PA/ED (Completed)		7,763.0	0.0	7,763.0	7,763.0				
Metro	AE322940011372	Professional Services for 710/91 PSR/PDS (Completed)		2,340.0	0.0	2,340.0	2,340.0				
Metro	MR315.49	Third Party Support for the 605 Corridor Hot Spots Interchanges Program Development (Gateway Cities, SCE, LA County)		300.0	0.0	300.0	300.0				
Metro	MR315.50	Freeway Early Action Projects (PA/ED & PS&E)		0.0	0.0	0.0	0.0				
Metro	AE39064000	I-605 Beverly Interchange Improvements (PR & PS&E)		3,229.3	0.0	3,229.3	3,229.3				
Metro	AE38849000	I-605 off-ramp at South Street Improvements Project (PR & PS&E)		4,452.3	0.0	4,452.3	4,452.3				
Metro	MR315.02	I-605 South St Improvements Construction	Add	0.0	20,000.0	20,000.0	0.0		5,000.0	10,000.0	5,000.0
Metro	MR315.35	SR-91 Atlantic to Cherry EB Aux Lane (PAED/PS&E)		7,500.0	0.0	7,500.0	7,500.0				
Metro	MR315.37	SR-91 Central to Acacia Improvements PAED	Chg	500.0	4,506.0	5,006.0	500.0	4,506.0			
Metro	MR315.63	SR-60 at 7th St Interch (PAED, PSE, ROW)	Chg	2,100.0	150.0	2,250.0	2,100.0	150.0			
Metro	MR315.73	I-605 at Valley Blvd Interch (PAED, PSE, ROW)	Chg	2,059.9	150.0	2,209.9	2,059.9	150.0			
Metro	MR315.72	Whittier Intersection Improvements (PSE, ROW)		2,308.1	0.0	2,308.1		2,308.1			
Metro	MR315.74	WB SR-91 Alondra Blvd to Shoemaker Ave (PSE,ROW)	Add	0.0	11,475.0	11,475.0		11,475.0			
		TOTAL METRO		112,224.5	49,206.0	161,430.5	101,916.4	34,615.1	9,899.0	10,000.0	5,000.0

ATTACHMENT A

Lead Agency	Fund Agr (FA) No.	PROJECT/LOCATION	Notes	Prior Alloc	Alloc Change	Current Alloc	Prior Yr Program	FY20	FY21	FY22	FY23
Caltrans	MR315.28	Third Party Support for the I-605 Corridor "Hot Spots" Interchanges Program Development, I-605/SR-60 PSR-PDS (Completed)		260.0	0.0	260.0	260.0				
Caltrans	MR315.47	Third Party Support for the I-605 Corridor "Hot Spots" Interchanges Program Development, I-605/SR-60 PA/ED		3,650.0	(800.0)	2,850.0	2,050.0	800.0			
Caltrans	MR315.24	Third Party Support for the I-605 Corridor "Hot Spots" Interchanges Program Development, I-605/I-5 PA/ED		2,069.8	(769.8)	1,300.0	1,300.0				
Caltrans	MR315.08	Third Party Support for the I-605 Corridor "Hot Spots" Interchanges Program Development, I-605/SR-91 PA/ED		776.3	(120.0)	656.3	656.3				
Caltrans	MR315.48	Third Party Support for the I-605 Corridor "Hot Spots" Interchanges Program Development, I-605 Intersection Improvements		60.0	0.0	60.0	60.0				
Caltrans	MR315.13	Third Party Support for the I-605 Corridor "Hot Spots" Interchanges Program Development, I-710/SR-91 PSR-PDS		234.0	0.0	234.0	234.0				
Caltrans	MR315.30	I-605 Beverly Interchange Improvements (Env. Doc.)		500.0	0.0	500.0	500.0				
Caltrans	MR315.31	I-605 from SR-91 to South Street Improvements Project (Env. Doc.)		500.0	0.0	500.0	500.0				
		TOTAL CALTRANS		8,050.1	(1,689.8)	6,360.3	5,560.3	800.0	0.0	0.0	0.0
Bellflower	MR315.16	Bellflower Blvd- Artesia Blvd Intersection Improvement Project		8,442.8	0.0	8,442.8	8,442.8				
Bellflower	MR315.33	Lakewood - Alondra Intersection Improvements: Construction		1,002.0	0.0	1,002.0	1,002.0				
		TOTAL BELLFLOWER		9,444.8	0.0	9,444.8	9,444.8	0.0	0.0	0.0	0.0
Cerritos	MR315.38	Carmenita - South Intersection Improvements, Construction		414.2	(0.2)	414.0	414.0				
Cerritos	MR315.39	Bloomfield - Artesia Intersection Improvements, ROW & Construction		1,544.2	0.0	1,544.2	1,544.2				
		TOTAL CERRITOS		1,958.4	(0.2)	1,958.2	1,958.2	0.0	0.0	0.0	0.0
Downey	MR315.03	Lakewood - Telegraph Intersection Improvements (Completed)		2,120.0	0.0	2,120.0	2,120.0				
Downey	MR315.14	Lakewood - Imperial Intersection Improvements		4,060.0	0.0	4,060.0	4,060.0				
Downey	MR315.27	Lakewood - Florence Intersection Improvements		4,925.0	0.0	4,925.0	4,925.0				
Downey	MR315.18	Bellflower - Imperial Highway Intersection Improvements (Completed)		2,740.4	0.0	2,740.4	2,740.4				
Downey	MR315.66	Lakewood Blvd at Firestone Blvd Intersection Improvm.		1,300.0	0.0	1,300.0	1,300.0				
		TOTAL DOWNEY		15,145.4	0.0	15,145.4	15,145.4	0.0	0.0	0.0	0.0

ATTACHMENT A

Lead Agency	Fund Agr (FA) No.	PROJECT/LOCATION	Notes	Prior Alloc	Alloc Change	Current Alloc	Prior Yr Program	FY20	FY21	FY22	FY23
LA County	MR315.07	Painter - Mulberry Intersection Improvements		2,410.0	0.0	2,410.0	2,410.0				
LA County	MR315.11	Valley View - Imperial Intersection Improvements		1,640.0	0.0	1,640.0	1,640.0				
LA County	MR315.15	Norwalk-Whittier Intersection Improvements		2,830.0	0.0	2,830.0	2,830.0				
LA County	MR315.23	Carmenita - Telegraph Intersection Improvements		1,400.0	0.0	1,400.0	1,400.0				
LA County	MR315.22	Norwalk-Washington Intersection Improvements (Completed)		550.0	0.0	550.0	550.0				
LA County	MR315.64	South Whittier Bikeway Access Improvements (Call Match) F9511		800.0	0.0	800.0	155.0	645.0			
LA County	MR306.01	Whittier Blvd (Indiana Street to Paramount Blvd) Corridor Project (Call Match) F9304	Add	0.0	700.0	700.0			700.0		
		TOTAL LA COUNTY		9,630.0	700.0	10,330.0	8,985.0	645.0	700.0	0.0	0.0
Lakewood	MR315.36	Lakewood Blvd Regional Capacity Enhancement		3,600.0	0.0	3,600.0	3,600.0				
Lakewood	MR315.04	Lakewood - Del Amo Intersection Improvements		5,504.3	0.0	5,504.3	5,504.3				
Lakewood	MR315.01	Lakewood Boulevard at Hardwick Street Traffic Signal Improvements	Add	0.0	300.0	300.0		300.0			
		TOTAL LAKEWOOD		9,104.3	300.0	9,404.3	9,104.3	300.0	0.0	0.0	0.0
Long Beach	MR315.67	2015 CFP - Artesia Complete Blvd (Call Match) F9130		900.0	0.0	900.0	0.0		900.0		
Long Beach	MR315.68	2015 CFP - Atherton Bridge & Campus Connection (Call Match) F9532		0.0	0.0	0.0	0.0				
Long Beach	MR315.69	Park or Ride (Call Match) F9808		212.6	(0.0)	212.6	126.7	71.8	14.1		
Long Beach	MR315.60	Soundwall on I-605 near Spring Street, PAED and PSE		350.0	0.0	350.0	350.0				
Long Beach	MR315.61	Lakewood - Spring Intersection Improvements, PSE and Construction		454.3	0.0	454.3	454.3				
Long Beach	MR315.62	Bellflower - Spring Intersection Improvements, PSE and Construction		492.8	0.0	492.8	492.8				
Long Beach	MR315.70	Artesia Boulevard Improvements		1,450.0	0.0	1,450.0	1,450.0				
		TOTAL LONG BEACH		3,859.7	(0.0)	3,859.7	2,873.8	71.8	914.1	0.0	0.0

ATTACHMENT A

Lead Agency	Fund Agr (FA) No.	PROJECT/LOCATION	Notes	Prior Alloc	Alloc Change	Current Alloc	Prior Yr Program	FY20	FY21	FY22	FY23
Norwalk	MR315.06	Studebaker - Rosecrans Intersection Improvements		1,670.0	0.0	1,670.0	1,670.0				
Norwalk	MR315.10	Bloomfield - Imperial Intersection Improvements		920.0	0.0	920.0	920.0				
Norwalk	MR315.17	Pioneer - Imperial Intersection Improvements		1,509.0	0.0	1,509.0	1,509.0				
Norwalk	MR315.26	Studebaker - Alondra Intersection Improvements		480.0	0.0	480.0	480.0				
Norwalk	MR315.43	Imperial Highway ITS Project, from San Gabriel River to Shoemaker Rd. (PAED, PS&E, CON)		3,380.4	0.0	3,380.4	3,380.4				
Norwalk	MR315.71	Firestone Blvd Widening Project		2,000.0	0.0	2,000.0	2,000.0				
		TOTAL NORWALK		9,959.4	0.0	9,959.4	9,959.4	0.0	0.0	0.0	0.0
Pico Rivera	MR315.05	Rosemead - Beverly Intersection Improvements	Deob	13,935.2	(456.2)	13,479.0	13,479.0				
Pico Rivera	MR315.09	Rosemead - Whittier Intersection Improvements		1,821.5	0.0	1,821.5	1,821.5				
Pico Rivera	MR315.19	Rosemead - Slauson Intersection Improvements		2,901.0	0.0	2,901.0	2,901.0				
Pico Rivera	MR315.21	Rosemead - Washington Intersection Improvements		53.0	0.0	53.0	53.0				
		TOTAL PICO RIVERA		18,710.7	(456.2)	18,254.5	18,254.5	0.0	0.0	0.0	0.0
Santa Fe Springs	MR315.40	Valley View - Rosecrans Intersection Improvements, Construction		824.0	0.0	824.0	824.0				
Santa Fe Springs	MR315.41	Valley View - Alondra Intersection Improvements, ROW & Construction		2,667.0	0.0	2,667.0	2,667.0				
Santa Fe Springs	MR315.42	Florence Avenue Widening Project, from Orr & Day to Pioneer Blvd (PAED, PSE, ROW)		3,800.0	0.0	3,800.0	3,800.0				
		TOTAL SANTA FE SPRINGS		7,291.0	0.0	7,291.0	7,291.0	0.0	0.0	0.0	0.0
Whittier	MR315.44	Santa Fe Springs Whittier Intersection Improvements: PSE, ROW, Construction		1,585.9	0.0	1,585.9	1,585.9				
Whittier	MR315.45	Painter Ave - Whittier Intersection Improvements: PSE, ROW, Construction		2,750.0	0.0	2,750.0	2,750.0				
Whittier	MR315.46	Colima Ave - Whittier Intersection Improvements: PSE, ROW, Construction		2,344.1	0.0	2,344.1	2,344.1				
		TOTAL WHITTIER		6,680.0	0.0	6,680.0	6,680.0	0.0	0.0	0.0	0.0
		TOTAL I-605/SR-91/I-405 "HOT SPOTS"		213,708.4	48,059.7	261,768.2	198,373.2	36,881.9	11,513.1	10,000.0	5,000.0

ATTACHMENT A

Lead Agency	Fund Agr (FA) No.	PROJECT/LOCATION	Notes	Prior Alloc	Alloc Change	Current Alloc	Prior Yr Program	FY20	FY21	FY22	FY23
Gateway Cities: INTERSTATE 710 SOUTH EARLY ACTION PROJECT				193,014.9	54,175.0	237,189.9	171,411.9	21,247.0	14,031.0	0.0	0.0
GCCOG	MOU.306.03	GCCOG Engineering Support Services		1,550.0	0.0	1,550.0	1,100.0	450.0			
		TOTAL GCCOG		1,550.0	0.0	1,550.0	1,100.0	450.0	0.0	0.0	0.0
Metro	PS4720-3334	Program/Project Management Support of Measure R Funds		200.0	0.0	200.0	200.0				
Metro	PS-4010-2540-02-17	I-710/I-5 Interchange Project Development		600.0	0.0	600.0	600.0				
Metro	various	Professional Services contracts for I-710 Utility Studies (North, Central, South)		25,046.0	0.0	25,046.0	25,046.0				
Metro	PS4340-1939	I-710 Corridor Project (PA/ED) EIR/EIS	Chg	32,520.9	7,975.0	40,495.9	40,495.9				
Metro	PS-4710-2744	I-710 Soundwall Feasibility & Project Development		3,509.0	0.0	3,509.0	3,509.0				
Metro	AE3722900	I-710 Soundwall Design Package 1		2,161.9	0.0	2,161.9	2,161.9				
Metro	PS4720-3330	I-710 Soundwall Design Package 3		5,271.6	0.0	5,271.6	5,271.6				
Metro	PS2198100	I-710 Soundwall Package 2		2,551.6	0.0	2,551.6	1,000.0	1,551.6			
Metro	MR306.02	I-710 Soundwall Package 2 ROW & Construction	Chg	4,448.0	500.0	4,948.0		1,000.0	3,448.0	500.0	
Metro	MR306.04	I-710 Soundwall Package 3 ROW & Construction	Add	0.0	45,000.0	45,000.0		5,000.0	10,000.0	30,000.0	
Metro	MOU.Calstart2010	Professional Services contract for development of zero emission technology report		150.0	0.0	150.0	150.0				
Metro	Bucket	I-710 ITS/Air Quality Early Action (Grant Match)		8,760.0	0.0	8,760.0	8,760.0				
Metro	MR306.41	FRATIS Modernization (Grant Match)		3,000.0	0.0	3,000.0	3,000.0				
Metro	MR306.38	Sustainable Transportation Planning Grant (Grant Match)		64.8	0.0	64.8	64.8				
Metro	MR306.59	Imperial Hwy Capacity Enhancements Project		865.0	0.0	865.0		865.0			
		TOTAL METRO		89,148.9	53,475.0	142,623.9	90,259.3	8,416.6	13,448.0	30,500.0	0.0
POLA	MR306.40	I-710 Eco-FRATIS Drayage Truck Efficiency Project (Grant Match)		240.0	0.0	240.0	240.0				
		TOTAL POLA		240.0	0.0	240.0	240.0	0.0	0.0	0.0	0.0

ATTACHMENT A

Lead Agency	Fund Agr (FA) No.	PROJECT/LOCATION	Notes	Prior Alloc	Alloc Change	Current Alloc	Prior Yr Program	FY20	FY21	FY22	FY23
Metro	13.01/USACE	Third Party Support Services for I-710 Corridor Project (US Army Corp of Eng)		100.0	0.0	100.0	100.0				
		TOTAL USACE		100.0	0.0	100.0	100.0	0.0	0.0	0.0	0.0
Metro	MR306.5B	Third Party Support Services for I-710 Corridor Project (So Cal Edison)		1,623.0	0.0	1,623.0	1,623.0				
Metro	MR306.39	I-710 Soundwall Project - SCE Utility Relocation Engineering Advance		75.0	0.0	75.0	75.0				
Metro	MR306.48	SCE design support I-710 Soundwall Package 3		400.0	0.0	400.0	400.0				
		TOTAL SCE		2,098.0	0.0	2,098.0	2,098.0	0.0	0.0	0.0	0.0
Caltrans	MR306.24	Reconfiguration of Firestone Blvd On-Ramp to I-710 S/B Freeway		1,450.0	0.0	1,450.0	1,450.0				
Caltrans	MR306.27	Third Party Support for I-710 Corridor Project EIR/EIS Enhanced IQA		3,500.0	0.0	3,500.0	3,500.0				
Caltrans	MR306.29	I-710 Early Action Project - Soundwall PA/ED Phase - Noise Study Only		100.0	0.0	100.0	100.0				
		TOTAL CALTRANS		5,050.0	0.0	5,050.0	5,050.0	0.0	0.0	0.0	0.0
LA County	MR306.16	Staff Support for the Review of the Draft I-710 South EIR/EIS		157.0	0.0	157.0	157.0				
LA County	MR306.01	Whittier Blvd (Indiana Street to Paramount Blvd) Corridor Project (Call Match) F9304		0.0	700.0	700.0		300.0	400.0		
		TOTAL LA COUNTY		157.0	700.0	857.0	157.0	300.0	400.0	0.0	0.0
Bell	MR306.37	Eastern at Bandini Rickenbacker Project (Call Match) F9200		178.6	(0.0)	178.6	178.6				
Bell	MR306.07	Staff Support for the Review of the Draft I-710 South EIR/EIS		136.0	0.0	136.0	136.0				
Bell	MR306.44	Gage Ave Bridge Replacement Project		66.8	0.0	66.8	66.8				
		TOTAL BELL		381.4	0.0	381.4	381.4	0.0	0.0	0.0	0.0

ATTACHMENT A

Lead Agency	Fund Agr (FA) No.	PROJECT/LOCATION	Notes	Prior Alloc	Alloc Change	Current Alloc	Prior Yr Program	FY20	FY21	FY22	FY23
Bell Gardens	MR306.08	Staff Support for the Review of the Draft I-710 South EIR/EIS		152.3	0.0	152.3	152.3				
Bell Gardens	MR306.35	Florence/Jaboneria Intersection Project (Call Match) F9111		283.4	0.0	283.4	0.0	100.4	183.0		
Bell Gardens	MR306.30	Florence Ave/Eastern Ave Intersection Widening (Call Match) F7120		1,184.7	0.0	1,184.7	1,184.7				
Bell Gardens	MR306.52	Garfield Ave & Eastern Ave Intersection Improvements		4,635.0	0.0	4,635.0	4,635.0				
		TOTAL BELL GARDENS		6,255.4	0.0	6,255.4	5,972.0	100.4	183.0	0.0	0.0
Commerce	MR306.23	Washington Blvd Widening and Reconstruction Project		13,500.0	0.0	13,500.0	13,500.0				
Commerce	MR306.09	Staff Support for the Review of the Draft I-710 South EIR/EIS		75.0	0.0	75.0	75.0				
Commerce	MR306.45	Atlantic Blvd. Improvements Project		1,500.0	0.0	1,500.0	1,500.0				
		TOTAL COMMERCE		15,075.0	0.0	15,075.0	15,075.0	0.0	0.0	0.0	0.0
Compton	MR306.10	Staff Support for the Review of the Draft I-710 South EIR/EIS		35.3	0.0	35.3	35.3				
		TOTAL COMPTON		35.3	0.0	35.3	35.3	0.0	0.0	0.0	0.0
Downey	MR306.18	Staff Support for the Review of the Draft I-710 South EIR/EIS		120.0	0.0	120.0	120.0				
Downey	MR306.20	Paramount Blvd/Firestone Intersection Improvements (Complete)		3,069.0	0.0	3,069.0	3,069.0				
Downey	MR306.42	Firestone Blvd Improvement Project (Old River Rd. to West City Limits)		323.0	0.0	323.0	323.0				
Downey	MR306.31	Lakewood Blvd Improvement Project		6,000.0	0.0	6,000.0	6,000.0				
Downey	MR306.49	Paramount Blvd at Imperial Highway Intersection Improvement Project		3,185.0	0.0	3,185.0	1,185.0	2,000.0			
		TOTAL DOWNEY		12,697.0	0.0	12,697.0	10,697.0	2,000.0	0.0	0.0	0.0

ATTACHMENT A

Lead Agency	Fund Agr (FA) No.	PROJECT/LOCATION	Notes	Prior Alloc	Alloc Change	Current Alloc	Prior Yr Program	FY20	FY21	FY22	FY23
Huntington Park	MR306.36	Staff Support for the Review of the Draft I-710 South EIR/EIS		15.0	0.0	15.0	15.0				
Huntington Park	MR306.53	Slauson Ave Congestion Relief Improvements		700.0	0.0	700.0	700.0				
		TOTAL HUNTINGTON PARK		715.0	0.0	715.0	715.0	0.0	0.0	0.0	0.0
Long Beach	MR306.19	Shoemaker Bridge Replacement Project		11,000.0	0.0	11,000.0	7,500.0	3,500.0			
Long Beach	MR306.11	Staff Support for the Review of the Draft I-710 South EIR/EIS		146.0	0.0	146.0	146.0				
Long Beach	MR306.22	Atlantic Ave/Willow St Intersection Improvements		300.0	0.0	300.0	300.0				
Long Beach	MR306.60	Shoreline Drive Realignment Project		2,800.0	0.0	2,800.0	520.0	2,280.0			
		TOTAL LONG BEACH		14,246.0	0.0	14,246.0	8,466.0	5,780.0	0.0	0.0	0.0
Lynwood	MR306.51	Staff Support for the Review of the Draft I-710 South EIR/EIS		20.0	0.0	20.0	20.0				
Lynwood	MR306.54	Imperial Highway Corridor Congestion Relief Improvements		0.0	0.0	0.0					
		TOTAL LYNWOOD		20.0	0.0	20.0	20.0	0.0	0.0	0.0	0.0
Maywood	MR306.12	Staff Support for the Review of the Draft I-710 South EIR/EIS		65.0	0.0	65.0	65.0				
Maywood	MR306.56	Slauson Ave and Atlantic Congestion Relief Improvements		445.0	0.0	445.0	445.0				
		TOTAL MAYWOOD		510.0	0.0	510.0	510.0	0.0	0.0	0.0	0.0
Paramount	MR306.13	Staff Support for the Review of the Draft I-710 South EIR/EIS		130.0	0.0	130.0	130.0				
Paramount	MR306.32	Garfield Ave Improvements		2,825.0	0.0	2,825.0	2,825.0				
		TOTAL PARAMOUNT		2,955.0	0.0	2,955.0	2,955.0	0.0	0.0	0.0	0.0
POLB	MR306.55	Pier B Street Freight Corridor Reconstructon		10,000.0	0.0	10,000.0	10,000.0				

ATTACHMENT A

Lead Agency	Fund Agr (FA) No.	PROJECT/LOCATION	Notes	Prior Alloc	Alloc Change	Current Alloc	Prior Yr Program	FY20	FY21	FY22	FY23
		TOTAL PORT OF LONG BEACH		10,000.0	0.0	10,000.0	10,000.0	0.0	0.0	0.0	
South Gate	MR306.14	Staff Support for the Review of the Draft I-710 South EIR/EIS		184.5	0.0	184.5	184.5				
South Gate	MR306.17	Atlantic Ave/Firestone Blvd Intersection Improvements (Complete)		12,400.0	0.0	12,400.0	12,400.0				
South Gate	MR306.33	Firestone Blvd Regional Corridor Capacity Enhancement Project		6,000.0	0.0	6,000.0	6,000.0				
South Gate	MR306.50	I-710 Soundwall Project - Package 1 Construction Phase		8,900.0	0.0	8,900.0	4,700.0	4,200.0			
South Gate	MR306.57	Imperial Highway Improvements Project		1,456.2	0.0	1,456.2	1,456.2				
South Gate	MR306.58	Fireston Blvd at Otis St Improvements		700.0	0.0	700.0	700.0				
		TOTAL SOUTH GATE		29,640.7	0.0	29,640.7	25,440.7	4,200.0	0.0	0.0	0.0
Vernon	MR306.15	Staff Support for the Review of the Draft I-710 South EIR/EIS		70.2	0.0	70.2	70.2				
Vernon	MR306.25	Atlantic Blvd Bridge Widening and Rehabilitation		2,070.0	0.0	2,070.0	2,070.0				
		TOTAL VERNON		2,140.2	0.0	2,140.2	2,140.2	0.0	0.0	0.0	0.0
		TOTAL I-710 SOUTH & EARLY ACTION PROJ		193,014.9	54,175.0	237,189.9	171,411.9	21,247.0	14,031.0	30,500.0	0.0

ATTACHMENT A

Lead Agency	Fund Agr (FA) No.	PROJECT/LOCATION	Notes	Prior Alloc	Alloc Change	Current Alloc	Prior Yr Program	FY20	FY21	FY22	FY23
North County: SR-138 Capacity Enhancements				200,000.0		200,000.0	154,800.0	45,200.0		0.0	0.0
Metro	MR330.01	SR-138 (AvenueD) PAVED (I-5 to SR-14)		19,400.0	0.0	19,400.0	19,400.0				
Metro/ Caltrans	MR330.12	SR 138 Segment 6 Construction		5,600.0	0.0	5,600.0	5,600.0				
TOTAL METRO				25,000.0	0.0	25,000.0	25,000.0	0.0	0.0	0.0	0.0
Lancaster	MR330.02	SR-138 (SR-14) Avenue K Interchange		15,000.0	0.0	15,000.0	15,000.0				
Lancaster	MR330.03	SR-138 (SR-14) Avenue G Interchange		15,000.0	0.0	15,000.0	3,100.0	11,900.0			
Lancaster	MR330.04	SR-138 (SR-14) Avenue J Interchange		10,000.0	0.0	10,000.0	3,300.0	6,700.0			
Lancaster	MR330.05	SR-138 (SR-14) Avenue L Interchange		5,000.0	0.0	5,000.0	1,200.0	3,800.0			
Lancaster	MR330.06	SR-138 (SR-14) Avenue M Interchange		20,000.0	0.0	20,000.0	20,000.0				
TOTAL LANCASTER				65,000.0	0.0	65,000.0	42,600.0	22,400.0	0.0	0.0	0.0
Palmdale	MR330.07	SR-138 Palmdale Blvd. (SR-138) 5th to 10th St. East		25,000.0	0.0	25,000.0	25,000.0				
Palmdale	MR330.08	SR-138 Palmdale Blvd. SB 14 Ramps		25,000.0	0.0	25,000.0	13,400.0	11,600.0			
Palmdale	MR330.09	SR-138 10th St. West Interchange		15,000.0	0.0	15,000.0	15,000.0				
Palmdale	MR330.10	SR-138 (SR-14) Widening Rancho Vista Blvd. to Palmdale Blvd		25,000.0	0.0	25,000.0	25,000.0				
Palmdale	MR330.11	SR-138 Avenue N Overcrossing		20,000.0	0.0	20,000.0	8,800.0	11,200.0			
TOTAL PALMDALE				110,000.0	0.0	110,000.0	87,200.0	22,800.0	0.0	0.0	0.0
TOTAL SR-138 CAPACITY ENH				200,000.0		200,000.0	154,800.0	45,200.0	0.0	0.0	0.0
Total Measure R Spent Inception to Date				1,085,319	109,537	1,184,855	949,419	139,269	44,307	1,695	6,800

Definitions:

Lead Agency is the primary project manager for the administration of scope and use of funds

Funding Agreement (FA): references the agreement number on file with Metro

Project Location: Describes the general scope and parameters of the project

Project Phase identifies which lifecycle phase the project is in at the time of reporting noted as follows:

PI - Project Initiation / PE - Preliminary Engineering / EA - Environmental Analysis / FD - Final Design / ROW - Right of Way Acq / CON - Construction

Notes: Provide a quick reference to reported change for the period such as:

Add - Addition of a new project / REP - Reprogram of funds / SCAD - Scope Addition / BAD - Budget Adjustment / DEL - Deletion

Prior Allocation identifies the reported project allocation reported in the previous report

Alloc Change denotes the amount of change occurring in the current reporting period.

**Board Report**

File #: 2019-0823, **File Type:** Contract**Agenda Number:** 13.

**PLANNING AND PROGRAMMING COMMITTEE
JANUARY 15, 2020****SUBJECT: GREEN LINE EXTENSION TO TORRANCE****ACTION: APPROVE RECOMMENDATIONS****RECOMMENDATION**

AUTHORIZE the Chief Executive Officer (CEO) to award and execute a 42-month, firm fixed price Contract No. AE63445000 with STV Incorporated (STV), in the amount of \$32,555,439 to provide environmental, advanced conceptual engineering (ACE) design, and optional preliminary engineering (PE) services on the Green Line Extension to Torrance Project for work in support of the environmental clearance study and design services, subject to resolution of protest(s), if any.

ISSUE

Measure M and Measure R allocate \$619 million and \$272 million respectively to the Green Line Extension to Torrance Project (Project). The project has been selected as one of the four Pillar Projects. In September 2018, the Metro Board received the Supplemental Alternatives Analysis Study and approved carrying two alternatives forward into environmental clearance. An environmental study is needed to identify and environmentally clear a Locally Preferred Alternative (LPA) pursuant to the California Environmental Quality Act (CEQA).

Board approval is needed for Contract No. AE63445000 to initiate the environmental study, select the LPA, and initiate PE design services. Completing these tasks now will support early project delivery strategies to potentially move the project into construction prior to the Measure M groundbreaking date of Fiscal Year (FY) 2026.

BACKGROUND**Measure M Project Description**

The project is identified in Measure M as an extension of the existing Metro Green Line light rail transit (LRT) to Crenshaw Boulevard in Torrance. The exact project description of all projects set forth in the Measure M ordinance are to be defined by the environmental process, which includes features such as termini, alignment, and stations. Per Measure M and Metro's 2009 Long Range Transportation Plan, the project has an \$891 million (2015 dollars) allocation based on the cost estimate that was current at the time that the Measure M Expenditure Plan was approved.

History

Metro completed an Alternatives Analysis (AA) Study in 2009, which studied transit alternatives along the Metro right-of-way (ROW) between downtown Los Angeles, Los Angeles International Airport (LAX) and the Ports of Los Angeles and Long Beach. The AA identified the Green Line Extension from Redondo Beach to Torrance, utilizing the Metro ROW, as the highest priority project in the AA. The Draft Environmental Impact Statement/Environmental Impact Report (EIS/EIR) studied No Build, Transportation Systems Management, and LRT Alternative along the ROW. After the failure of Measure J in 2012, this Draft EIS/EIR was put on hold due to funding concerns.

After the passage of Measure M, Metro reinitiated the planning studies for the project in spring 2017 with the Supplemental Alternative Analysis (SAA) which was completed in September 2018.

DISCUSSION

At the September 2018 meeting (Legistar File 2018-0317), the Board received the findings of the Green Line Extension to Torrance SAA and approved carrying forward two (2) Build Alternatives for environmental review (Attachment C):

- Metro Green Line Marine/Redondo Station to 190th Street (Metro ROW overcrossing, Manhattan/Inglewood); and
- Hawthorne Blvd. to 190th Street (Hawthorne/166th Street).

Each alternative would share the same alignment approximately south of 190th Street and terminate at the Torrance Transit Center.

Equity Platform

The project is consistent with the adopted Metro Equity Platform Framework and will provide new benefits of enhanced mobility and regional access to minority and/or low-income populations within the project area. The project would run primarily through Environmental Justice (EJ) communities, which the completed SAA defines as populations of over 50% minority, low-income, or limited-English proficiency. These communities are burdened by existing land use and transportation issues within the project area. Further, the South Bay as a whole is not well connected to the regional transit system. According to the 2016 Southern California Association of Governments Regional Transportation Plan/ Sustainable Communities Strategy, population and employment within the project area are projected to grow by 8% and 21%, respectively, by 2040.

The project will improve access to these jobs, as well as to major activity centers, including educational and medical institutions, and recreational opportunities within the project area and across the Los Angeles region. All of the aforementioned project benefits will collectively expand access to opportunities for residents of the project area.

DETERMINATION OF SAFETY IMPACT

These actions will not have any impact on the safety of our customers and/or employees because this project is at the beginning of the environmental study and design phase.

FINANCIAL IMPACT

The FY 2020 budget includes \$1,500,000 for Professional Services in Cost Center 4350, Project 460304 (Green Line Extension). Since this is a multi-year program, the Cost Center Manager and Chief Planning Officer will be responsible for budgeting in future years.

Impact to Budget

The sources of funds are Measure R and Measure M 35% Transit Construction funds. These funds are not eligible for bus and/or rail operating expenses.

IMPLEMENTATION OF STRATEGIC PLAN GOALS

The recommendation supports strategic plan goal 1: provide high quality mobility options that enable people to spend less time traveling. The project area currently faces a number of interrelated land use and transportation issues. Major arterial roadways are congested throughout much of the day. Consequently, bus routes in the South Bay experience slow travel speeds and a high variation in travel times. There are numerous transit operators in the project area but poor connections between local and regional systems. Additionally, there is a lack of high quality, frequent transit services that connect to key destinations and employment centers locally and outside the project area.

A more convenient and reliable connection between the Metro rail system and South Bay communities would reduce transit travel times and provide a viable alternative to driving. The project aims at providing a reliable, high-frequency transit service and improving mobility in southwestern Los Angeles County by enhancing the regional transit network in the South Bay.

ALTERNATIVES CONSIDERED

The Board could choose not approve any or all of the recommendations. This is not recommended as this work is necessary in order to select the locally preferred alternative and implement the project.

NEXT STEPS

Upon Board approval, staff will execute Contract No. AE63445000 with STV to complete the environmental study, ACE, and optional PE design services.

ATTACHMENTS

Attachment A - Procurement Summary
Attachment B - DEOD Summary
Attachment C - Project Study Area Map

Prepared by: Dolores Roybal Saltarelli, Senior Director, Countywide Planning & Development, (213) 922-3024
David Mieger, Acting SEO, Countywide Planning & Development, (213) 922-3040

Reviewed by: James de la Loza, Chief Planning Officer, (213) 922-2920
Debra Avila, Chief Vendor/Contract Management Officer, (213) 418-3051

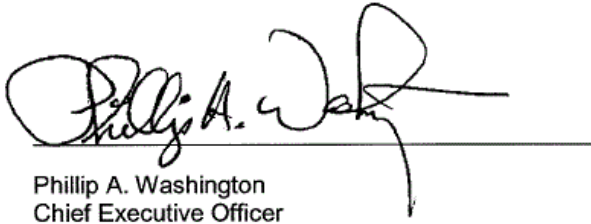

Phillip A. Washington
Chief Executive Officer

PROCUREMENT SUMMARY

GREEN LINE EXTENSION TO TORRANCE/AE63445000

1.	Contract Number: AE63445000	
2.	Recommended Vendor: STV Incorporated	
3.	Type of Procurement (check one): <input type="checkbox"/> IFB <input type="checkbox"/> RFP <input checked="" type="checkbox"/> RFP-A&E <input type="checkbox"/> Non-Competitive <input type="checkbox"/> Modification <input type="checkbox"/> Task Order	
4.	Procurement Dates:	
	A. Issued: June 17, 2019	
	B. Advertised/Publicized: June 17, 2019	
	C. Pre-Proposal Conference: June 25, 2019	
	D. Proposals Due: July 31, 2019	
	E. Pre-Qualification Completed: September 25, 2019	
	F. Conflict of Interest Form Submitted to Ethics: August 1, 2019	
	G. Protest Period End Date: January 23, 2020	
5.	Solicitations Picked up/Downloaded: 113	Proposals Received: 3
6.	Contract Administrator: Lily Lopez	Telephone Number: (213) 922-4639
7.	Project Manager: Dolores Roybal Saltarelli	Telephone Number: (213) 922-3024

A. Procurement Background

This Board Action is to approve Contract No. AE63445000 issued in support of the Green Line Extension to Torrance Project. The intent of the project is to provide environmental, advanced conceptual engineering (ACE) design, and optional preliminary engineering (PE) services on the Green Line Extension to Torrance Project for work in support of the environmental clearance study and design services. Board approval of contract award is subject to resolution of all properly submitted protest(s).

The Request for Proposal (RFP) was issued in accordance with Metro's Acquisition Policy and the contract type is firm fixed price. The RFP was issued with an SBE goal of 25% and a 3% DVBE goal.

Three amendments were issued during the solicitation phase of this RFP:

- Amendment No. 1, issued on June 28, 2019, provided revisions related to the submittal requirements and evaluation criteria.
- Amendment No. 2, issued on July 3, 2019, provided revisions clarifying some tasks of the Scope of Services.
- Amendment No. 3, issued on July 18, 2019, provided additional clarification to the Scope of Services.

A pre-proposal conference was held on June 25, 2019, attended by 63 participants representing 49 firms. There were 18 questions asked and responded to during the solicitation phase.

A total of 113 firms downloaded the RFP and were included in the planholders list. A total of three proposals were received on July 31, 2019 from the following firms:

- Dewberry Engineers Inc. (Dewberry)
- Stantec Consulting Services Inc. (Stantec)
- STV Incorporated (STV)

B. Evaluation of Proposal

A Proposal Evaluation Team (PET) consisting of staff from Metro's Countywide Planning, Transit Project Delivery (Program Management) and Environmental Compliance was convened and conducted a comprehensive technical evaluation of the proposals received.

The proposals were evaluated based on the following evaluation criteria and weights:

- | | |
|--|-----|
| • Degree of Skills and Experience of Team (includes Prime Contractor and Subcontractors) | 15% |
| • Experience and Capabilities of Personnel of the Team | 25% |
| • Effectiveness of Team Management Plan | 15% |
| • Understanding of Work and Approach for Implementation | 35% |
| • Innovation | 10% |

The evaluation criteria are appropriate and consistent with criteria developed for other, similar Architect and Engineers (A&E) environmental procurements. Several factors were considered when developing these weights, giving the greatest importance to understanding of work and approach for implementation. The PET evaluated the proposals according to the pre-established evaluation criteria. This is an A&E, qualifications based procurement; therefore, price cannot be used as an evaluation factor pursuant to state and federal law.

All three proposals received were determined to be within the competitive range.

During the period of July 31 to August 23, 2019, the PET members independently evaluated and scored the technical proposals. All offerors were invited for oral presentations on August 6, 2019, which provided each firm the opportunity to present each team's qualifications and respond to the evaluator's questions.

Following the interviews, the PET finalized technical scores based on both written proposals and the clarifications from the oral interviews. On August 23, 2019, the PET unanimously agreed that the final ranking of proposals scored STV's proposal

as the highest technically qualified. The PET concluded that STV’s proposal presented the highest level of skills, a low-risk and achievable management plan, and demonstrated the best understanding of the project.

Qualifications Summary of Recommended Firm:

STV provides engineering services, planning, design, architectural, environmental, and construction management services to transportation, design-build, institutional and commercial building, advanced technology, industrial, and defense markets. STV will be the prime contractor for the project, in collaboration with multiple experienced subcontractor firms. STV will lead the program management responsibilities, supported by key partner AECOM Technical Services, Inc. whose primary role will be the CEQA/NEPA and ACE/PE support.

The STV team demonstrated depth of experience delivering similar projects and has experience managing projects such as the 2008 Green Line Extension to Torrance (GLET), through the Alternatives Analysis, then through preparation of the joint CEQA/NEPA administrative draft environmental document, conceptual engineering, and administrative draft environmental process, and finally through the recent Supplemental AA process. Additionally, STV has worked on Metro’s Airport Metro Connector (AMC), East San Fernando Valley Transit Corridor (ESFVTC), Purple Line Extension Section 2 Design-Build, and the California High-Speed Rail (CHSR) Burbank to Los Angeles and Los Angeles to Anaheim project sections.

A summary of the PET scores is provided below:

1	Firm	Average Score	Factor Weight	Weighted Average Score	Rank
2	STV				
3	Degree of Skills and Experience of Team (includes Prime Contractor and Subcontractors)	80.00	15.00%	12.00	
4	Experience and Capabilities of Personnel of the Team	78.76	25.00%	19.69	
5	Effectiveness of Team Management Plan	74.27	15.00%	11.14	
6	Understanding of Work and Approach for Implementation	77.51	35.00%	27.13	
7	Innovation	75.00	10.00%	7.50	
8	Total		100.00%	77.46	1
9	Dewberry				
10	Degree of Skills and Experience of Team (includes Prime Contractor and Subcontractors)	75.33	15.00%	11.30	
11	Experience and Capabilities of Personnel of the Team	75.00	25.00%	18.75	

12	Effectiveness of Team Management Plan	73.80	15.00%	11.07	
13	Understanding of Work and Approach for Implementation	75.00	35.00%	26.25	
14	Innovation	75.00	10.00%	7.50	
15	Total		100.00%	74.87	2
16	Stantec				
17	Degree of Skills and Experience of Team (includes Prime Contractor and Subcontractors)	71.33	15.00%	10.70	
18	Experience and Capabilities of Personnel of the Team	72.92	25.00%	18.23	
19	Effectiveness of Team Management Plan	73.33	15.00%	11.00	
20	Understanding of Work and Approach for Implementation	77.51	35.00%	27.13	
21	Innovation	73.30	10.00%	7.33	
22	Total		100.00%	74.39	3

C. Cost Analysis

The recommended price of \$32,555,439 has been determined to be fair and reasonable based upon an independent cost estimate (ICE), technical analysis, a cost analysis, fact finding, and negotiations. Staff successfully negotiated a cost savings of \$6,159,057.

	Proposer Name	Proposal Amount	Metro ICE	Negotiated amount
1.	STV	\$38,714,496	\$18,605,678	\$32,555,439

There is a variance between the estimated level of effort and the final level of effort in the negotiated amount. The variance accounts for an increased level of effort that was not accounted for in the ICE in both Advanced Conceptual Engineering (ACE) and the optional Preliminary Engineering (PE) design services to identify key engineering challenges for the build alternatives moving forward in the environmental document and expedite project delivery. By identifying engineering challenges earlier in the environmental phase, the selection of a Locally Preferred Alternative (LPA) can be facilitated. Pending the selection of the LPA, the optional PE services included in the level of effort can be initiated and the design of the LPA can be significantly advanced. This strategy has not been done before when initiating the environmental study phase of a project. It is being utilized now for this four-pillar project to enable revenue service by 2028.

D. Background on Recommended Contractor

The recommended firm, STV, based in Douglassville, Pennsylvania, was established in 1912 as a multi-disciplinary planning, environmental, engineering, architectural, and construction management firm. STV has worked on several Metro projects and performed satisfactorily. The projects include Metro's AMC, ESFVTC, Purple Line Extension Section 2 Design-Build, and CHSR Burbank to Los Angeles and Los Angeles to Anaheim project sections.

STV has assembled a team of 16 subcontractors, 13 of which are SBEs and one DVBE, including AECOM Technical Services, Inc., BA Inc., Cityworks Design, Chen Ryan Associates, Inc., Coast Surveying, Inc., Diaz Yourman & Associates, Epic Land Solutions, Inc., Fehr & Peers, McLean & Schultz, Inc., Safeprobe, Inc., SKA Design, Soteria Company, LLC, Terry A. Hayes Associates, Inc., The LeBaugh Group, Inc., Vicus LLC and Yunsoo Kim Design, Inc.

DEOD SUMMARY

GREEN LINE EXTENSION TO TORRANCE/AE63445000

A. Small Business Participation

The Diversity and Economic Opportunity Department (DEOD) established a 25% Small Business Enterprise (SBE) and 3% Disabled Veteran Business Enterprise (DVBE) goal for this solicitation. STV Incorporated exceeded the goal by making a 25.13% SBE and 3.10% DVBE commitment.

SMALL BUSINESS GOAL	25% SBE 3% DVBE	SMALL BUSINESS COMMITMENT	25.13% SBE 3.10% DVBE
------------------------------------	----------------------------	--	----------------------------------

	SBE Subcontractors	% Committed
1.	BA, Inc.	6.59%
2.	Chen Ryan Associates, Inc.	2.45%
3.	Cityworks Design	2.01%
4.	Coast Surveying, Inc.	1.42%
5.	Diaz Yourman & Associates	2.76%
6.	Epic Land Solutions, Inc.	0.65%
7.	McLean & Schultz, Inc.	3.66%
8.	Safeprobe, Inc.	0.53%
9.	Sanchez/Kamps Associates Design	0.88%
10.	Soteria Company, LLC	1.34%
11.	Terry A. Hayes Associates, Inc.	1.16%
12.	Vicus LLC	1.03%
13.	Yunso Kim Design, Inc.	0.65%
	Total SBE Commitment	25.13%

	DVBE Subcontractors	% Committed
1.	The LeBaugh Group, Inc.	3.10%
	Total DVBE Commitment	3.10%

B. Prevailing Wage Applicability

Prevailing Wage requirements are applicable to this project. DEOD will monitor contractors' compliance with the State of California Department of Industrial Relations (DIR), California Labor Code, and, if federally funded, the U S Department of Labor (DOL) Davis Bacon and Related Acts (DBRA). Trades that may be covered

include: surveying, potholing, field, soils and materials testing, building construction inspection, construction management and other support trades.

C. Living Wage Service Contract Worker Retention Policy Applicability

The Living Wage and Service Contract Worker Retention Policy is not applicable to this contract.

D. Project Labor Agreement/Construction Careers Policy

Project Labor Agreement/Construction Careers Policy is not applicable to this Contract. Project Labor Agreement/Construction Careers Policy is applicable only to construction contracts that have a construction contract value in excess of \$2.5 million.

GLET Project Study Area Map

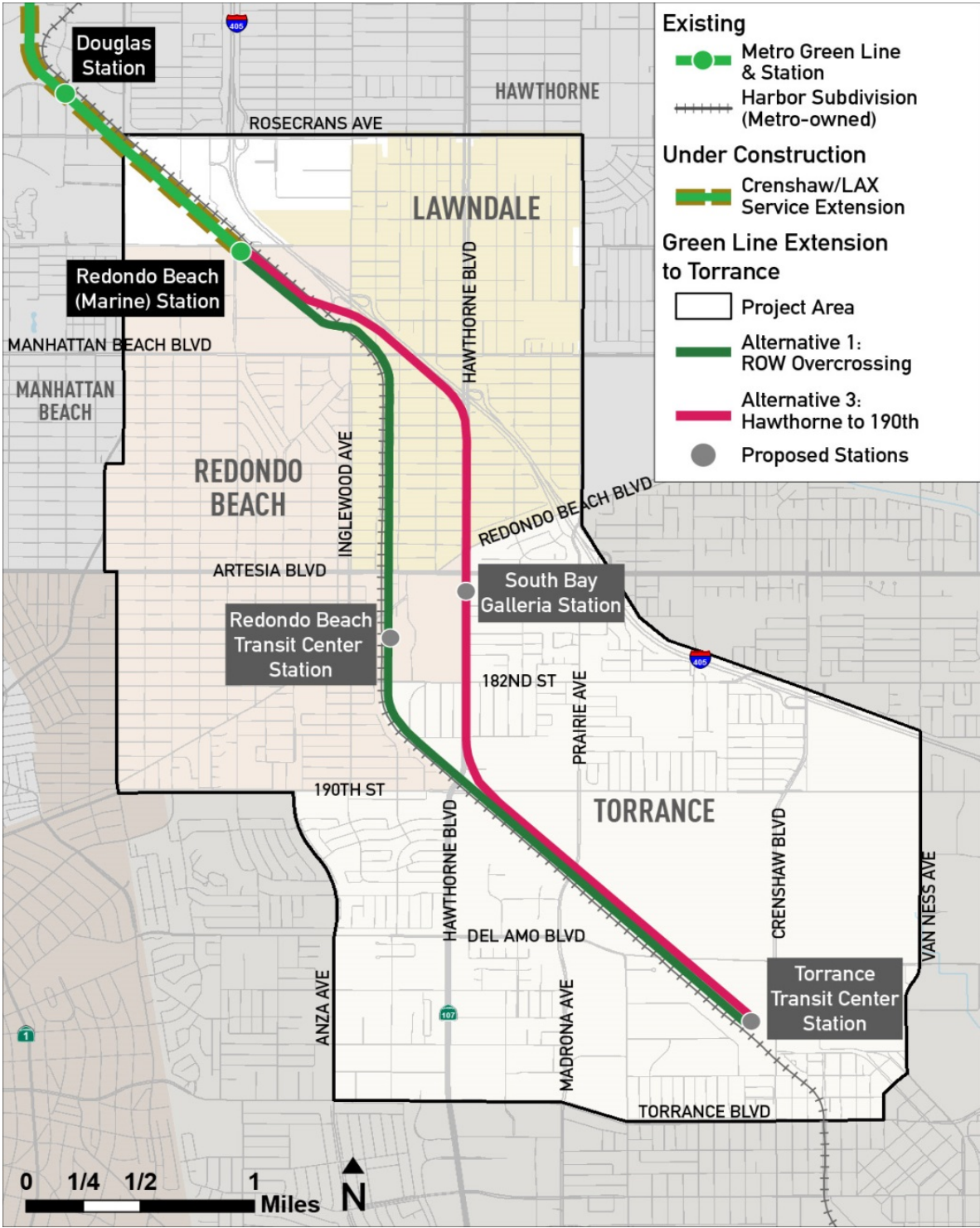

Green Line Extension to Torrance

Award of Environmental and Design Contract

Planning and Programming Committee
January 15, 2020
Legistar File No. 2019-0823



Recommendation

Authorize the CEO to execute:

- Environmental Study, advanced conceptual engineering (ACE) design and optional preliminary engineering (PE) services with STV Incorporated (STV) in the amount of \$32,555,439

Project Background

- September 2018, the Board approved the Supplemental Alternatives Study, moving two build alternatives forward into environmental clearance.
- One of the four Pillar projects projected to be in service by 2028.
- Contract will allow completion of construction contract award without further procurements.
- Commitments for Small Business Enterprise (SBE) set at 25.13% and Disabled Veteran Business Enterprise (DVBE) at 3.10%

Build Alternatives Under Consideration

Redondo Beach Station to 190th St

- Alternative 1: ROW Overcrossing
- Alternative 3: Hawthorne Blvd to 190th

190th to Torrance TC

- All Alternatives Identical

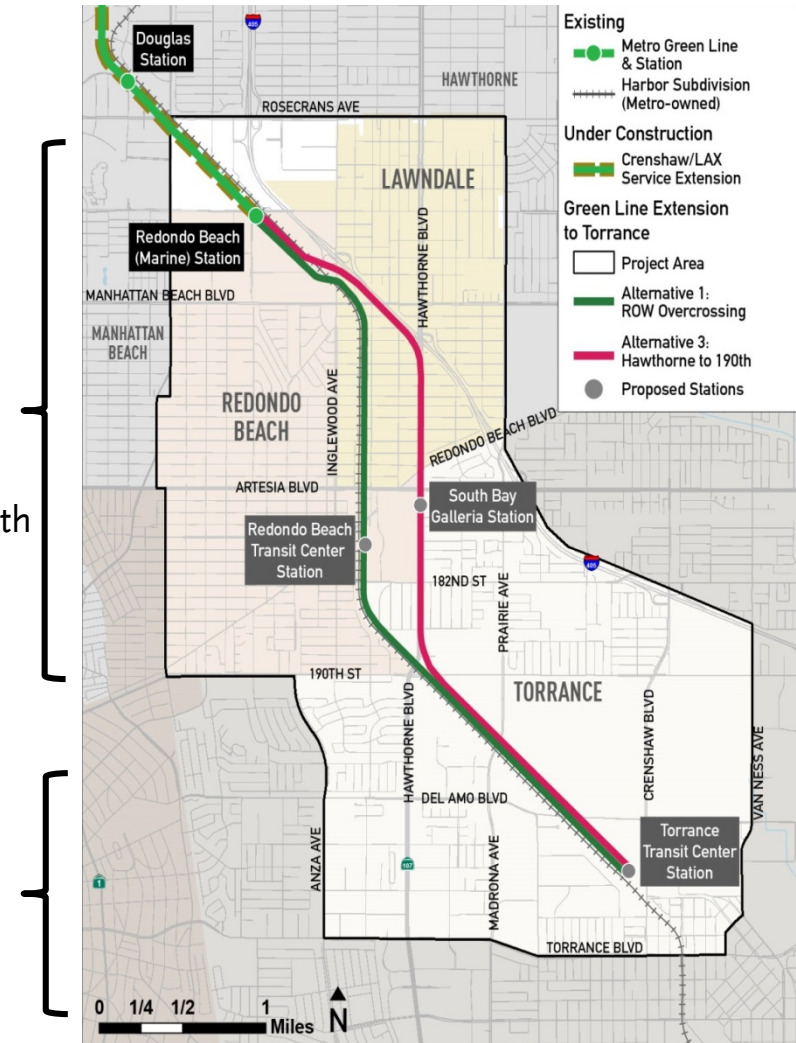

Next Step/Project Schedule

- February 2020 - Project kickoff; initiate the environmental process
- April 2020 - Community updates and stakeholder outreach
- Fall 2021- Locally preferred alternative selected by Board following public hearings on Draft EIR



Board Report

File #: 2019-0806, File Type: Contract

Agenda Number: 14.

PLANNING AND PROGRAMMING COMMITTEE JANUARY 15, 2020

SUBJECT: PURPLE LINE EXTENSION SECTION 1, CRENSHAW/LAX AND REGIONAL CONNECTOR FIRST/LAST MILE PLANNING

ACTION: APPROVE RECOMMENDATIONS

RECOMMENDATION

AUTHORIZE the Chief Executive Officer (CEO) to:

- A. Prepare First/Last Mile (FLM) plans for Purple Line Extension (PLE) Section 1 stations;
- B. Execute Modification No. 3 to Task Order No. AE115994000 with IBI Group for the Purple Line Sections 2 and 3 First/Last Mile (FLM) Plan and Guidelines to accommodate PLE Section 1 FLM planning work in the amount of \$378,864 increasing the task order value from \$1,171,722 to \$1,550,586; and
- C. Subsequently initiate planning for stations on the Crenshaw/LAX line and Regional Connector.

ISSUE

In May 2016, the Metro Board approved Motion 14.1 (Legistar 2016-0442) directing staff to pursue a variety of FLM planning and implementation activities. This direction included integrating FLM into the planning, design, and construction of all Metro transit projects, as well as conducting FLM studies and preliminary design for all existing stations. Staff placed priority for FLM planning on those projects that were in the pre-construction stage when the motion was adopted - Airport Metro Connector, Gold Line Foothill Extension 2B, Purple Line Sections 2 and 3, and East San Fernando Valley. Those FLM plans have been adopted by the Board or are underway and will be brought to the Board in early 2020. For the reasons listed below, staff recommends that the Purple Line Section 1 (PLE Section 1), Regional Connector and Crenshaw/LAX, which were under active procurement or contract for construction at the time of adoption of Motion 14.1, be the next highest priority.

BACKGROUND

Metro's FLM program is intended to facilitate location-specific access and safety improvements around transit stations, recognizing that approximately 85% of Metro transit users get to stations on foot or bicycle (or other rolling mode such as scooter, skateboard). FLM improvements include

sidewalks, crosswalks, ADA-compliant curb ramps, bicycle lanes, and lighting among others. Metro's FLM work emphasizes pedestrian improvements at a ½-mile radius from stations, and bicycle/rolling modes at up to 3 miles.

Metro Board Motions 14.1 (May 2016) and 14.2 (June 2016) directed a slate of activities that established Metro's on-going FLM program. This included direction to integrate FLM into the process for transit corridors, prepare station area plans for the existing system, technical assistance, funding, and implementation incentives. As a result, Metro has progressed on this work effort by completing a number of FLM plans, and elevating the visibility of FLM planning and interest among jurisdictions and stakeholders.

DISCUSSION

PLE Section 1

Staff is recommending FLM plans be prepared now for PLE Section 1 for the following reasons:

- *Existing conditions and need:* PLE Section 1 consists of three stations (La Brea, Fairfax, La Cienega) in heavily traveled locations with a variety of trip origins and destinations including major cultural, commercial/employment, and other attractions. Each station is projected to serve over 10,000 riders daily, and together they provide access to more than 27,000 jobs and 16,000 residents within a half-mile. These stations present distinct opportunities and challenges for pedestrian and rolling mode access, including a number of nearby intersections and corridors with significant observed safety and accessibility concerns. The PLE Section 1 station areas also contain a number of major streets included in the City of Los Angeles High Injury Network (HIN) including 3.3 miles of HIN along portions of Wilshire Boulevard, Fairfax Avenue, 3rd Street, and Olympic Boulevard.
- *Persistent community interest:* Metro staff has been alerted to substantial and ongoing interest in FLM planning for PLE Section 1 stations. This has arisen in a number of contexts, including coordination with cities on ongoing FLM planning for PLE Sections 2 and 3, the initiation of transit-oriented development (TOD) planning grants for PLE Section 1 station areas, and contacts from community groups and individuals.
- *Synergies with PLE Sections 2 and 3:* Motion 14.1 directs FLM planning for the Metro system, divided into two categories: 254 existing stations (including all rail and top 100 ridership bus stops), and all new Metro transit projects. PLE Section 1 is categorized as "existing" for purposes of the original Board direction. Nevertheless, given that staff is tasked with carrying out planning for all rail stations, it is expeditious to use the current procured task order to also complete plans for PLE Section 1. Additionally, consolidating FLM efforts on PLE Section 1 with on-going PLE Sections 2 and 3 FLM planning on the same line will provide a more cohesive and comprehensible process for stakeholders and the public, and best position these soon-to-be-completed stations to realize comprehensive access improvements.

The recommended action for PLE Section 1 FLM activities necessitates a modification to Task Order No. AE115994000 with IBI Group. The current task order scope includes FLM planning activities resulting in pathway network maps, project lists including cost estimates, prioritization, and process

documentation for four stations for PLE Sections 2 and 3. The modification would provide for the same activities and deliverables for three additional stations on PLE Section 1 and further includes budget to engage community-based organizations (CBOs) to assist with community engagement.

Crenshaw/LAX and Regional Connector

PLE Section 1, for purposes of FLM Board direction, is situated similarly to other transit lines that were under construction at the time of Motion 14.1, including the Crenshaw/LAX line and Regional Connector. The recommendation to proceed on FLM planning for PLE Section 1 at this time responds to the unique circumstances for the project as outlined above. Nevertheless, it remains a priority to provide FLM planning for all under-construction stations. As such, staff further proposes to proceed on plan development for Crenshaw/LAX and Regional Connector stations as other current FLM planning efforts conclude and staff resources are available. Note, however, that a number of Crenshaw/LAX and Regional Connector stations are addressed in existing FLM or equivalent plans, notably the City of Los Angeles Crenshaw Streetscape Plan, the previous Metro FLM plans for three stations located in the City of Inglewood and Aviation/96th Street Station, and the Connect US Action Plan. Metro's future FLM planning work on these lines will cover stations that have not been addressed in other efforts. Metro staff will update the Board on status and timing of FLM planning for Crenshaw/LAX and Regional Connector in future FLM program status reports.

Equity Platform

FLM planning work is substantially shaped by the Equity Platform. Specifically, the program integrates the four Equity Platform pillars as follows:

- I. Define and Measure: FLM planning includes a significant assessment of existing conditions with a focus on transportation safety.
- II. Listen and Learn: Plans are substantially shaped through a broad-based community engagement process that allows residents and employees within station areas to identify mobility, connectivity, and safety issues. The contract modification recommended to be authorized here would allow for engaging CBOs as part of the project team.
- III. Focus and Deliver: FLM planning results in a prioritized project list, cost estimates, and feasibility screenings that allow for an efficient transition to funding and design processes.
- IV. Train and Grow: Each FLM planning effort includes a lessons-learned review that is intended to inform and improve future work.

DETERMINATION OF SAFETY IMPACT

There is no direct safety impact associated with the recommended action. Note that FLM planning is intended to identify projects that, if implemented, would improve safety conditions for transit riders accessing Metro stations. Specific safety assessment of those projects will be performed with any subsequent implementation action.

FINANCIAL IMPACT

The proposed action will increase Task Order No. AE115994000 with IBI Group by \$378,864 from

\$1,171,722 to \$1,550,586. Professional Services and staff activities for FLM planning are included in the current fiscal year budget at Project 405310 task 01 and at Project 405306 task 01.01. The Cost Center manager and Chief Planning Officer will be responsible for budgeting costs in future years.

Impact to Budget

The source of funds for this action is Measure M 2% Active Transportation. These funds are not eligible for Metro Bus and Rail Operations.

IMPLEMENTATION OF STRATEGIC PLAN GOALS

The FLM program advances several Strategic Plan Goals including:

Strategic Plan Goal #1. Provide high-quality mobility options that enable people to spend less time traveling: FLM identifies key access routes to Metro transit stations, and further identifies and prioritizes project improvements for safety and connectivity.

Strategic Plan Goal #2. Deliver outstanding trip experiences for all users of the transportation system: FLM improvements provide for more direct, efficient, safe, and pleasant access to stations, as well as considering improved transfers, signage and wayfinding, and traveler information.

Strategic Plan Goal #3. Enhance communities and lives through mobility and access to opportunity: FLM planning includes a clear focus on targeting investment to places that need it most due to safety, socio-economic, and other factors

Strategic Plan Goal #4. Transform LA County through regional collaboration and national leadership: FLM planning works closely with local jurisdictions and communities to identify and prioritize projects and to enable subsequent implementation.

ALTERNATIVES CONSIDERED

The Board may choose to not direct the FLM planning activities at this time. This option is not recommended as it would result in missing opportunities to leverage the existing PLE FLM planning contract and the ability to align FLM planning with other activities, notably the City's TOD station area planning for PLE 1, and may result in reduced opportunities to implement access improvements prior to completion of new stations.

NEXT STEPS

Upon Board approval, staff will execute Modification No. 3 to Task Order No. AE115994000 and proceed with developing FLM plans for PLE Section 1. Upon completion, staff will report to the Board for adoption and consideration of next steps toward implementation. Separately, staff will provide updates to the Board on timing and status of planning for Crenshaw/LAX and Regional Connector as described in this report. Staff will further report on prioritization of FLM planning for existing stations as part of upcoming program updates.

ATTACHMENTS

Attachment A - Procurement Summary

Attachment B - Task Order Modification/Change Order Log

Attachment C - DEOD Summary

Prepared by: Jacob Lieb, Senior Director, Countywide Planning & Development, (213) 922-4132
Nick Saponara, EO (Interim), Countywide Planning & Development, (213) 922-4313
Holly Rockwell, SEO - Real Estate, Transit Oriented Communities and Transportation Demand

Reviewed by: James de la Loza, Chief Planning Officer, (213) 922-2920
Debra Avila, Chief Vendor/Contract Management Officer, (213) 418-3051

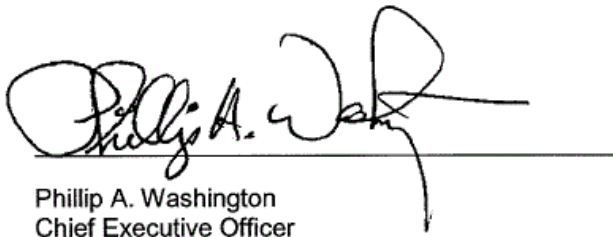

Phillip A. Washington
Chief Executive Officer

PROCUREMENT SUMMARY

PURPLE LINE FIRST/LAST MILE GUIDELINES / AE115994000

1.	Contract Number: Task Order No. AE115994000		
2.	Contractor: IBI Group		
3.	Mod. Work Description: Purple Line Extension (PLE) Section 1 First/Last Mile (FLM) planning work.		
4.	Work Description: Purple Line First/Last Mile Guidelines		
5.	The following data is current as of: 12/09/19		
6.	Contract/TO Completion Status:		Financial Status:
	Award Date:	06/05/18	Awarded Task Order Amount: \$986,246
	Notice to Proceed (NTP):	06/23/18	
	Original Completion Date:	02/28/20	Value of Mods. Issued to Date (including this action): \$564,340
	Current Est. Complete Date:	01/29/21	Total Amount (including this action): \$1,550,586
7.	Contract Administrator: Erica Rodriguez		Telephone Number: (213) 922-1064
8.	Project Manager: Jacob Lieb		Telephone Number: (213) 418-3224

A. Contract Action Summary

This Board Action is to approve Modification No. 3 to Task Order No. AE115994000 under Contract No. PS4010-3041-BB-XX for PLE Section 1 FLM planning work. This Task Order Modification also extends the period of performance through January 29, 2021.

This Task Order Modification was processed in accordance with Metro's Acquisition Policy. The contract/task order type is firm fixed price. All other terms and conditions remain in effect.

On June 5, 2018, Task Order No. AE115994000 in the firm fixed price of \$986,246 was issued to IBI Group, a contractor on the Countywide Planning Bench.

Refer to Attachment B – Task Order Modification/Change Order Log for modifications issued to date.

B. Cost Analysis

The recommended price has been determined to be fair and reasonable based upon an independent cost estimate (ICE), cost analysis, technical analysis and negotiations. Some direct labor rates were re-negotiated to current market rates and fee remained unchanged.

Metro staff successfully negotiated a cost savings of \$22,624.

Proposal Amount	Metro ICE	Negotiated Amount
\$401,488	\$398,588	\$378,864

ATTACHMENT B

**TASK ORDER MODIFICATION/CHANGE ORDER LOG
PURPLE LINE FIRST/LAST MILE GUIDELINES
TASK ORDER NO. AE115994000 VALUE ISSUED TO DATE**

Mod. No.	Description	Status (approved or pending)	Date	Amount
1	Purple Line Sections 2 and 3 First/Last Mile (FLM) Plan and Guidelines - Provide additional community engagement for the Purple Line FLM planning and further the development of the FLM Guidelines.	Approved	5/31/19	\$118,512
2	Additional level of effort and work for increasing use of dockless mobility devices in and around Purple Line stations.	Approved	10/03/19	\$66,964
3	Purple Line Extension Section 1 FLM planning work and extension of the period of performance through January 29, 2021.	Pending	Pending	\$378,864
	Task Order Modification Total:			\$564,340
	Original Task Order Amount:		06/05/18	\$986,246
	Total:			\$1,550,586

DEOD SUMMARY

PURPLE LINE EXTENSION SECTION 1, CRENSHAW/LAX AND REGIONAL
CONNECTOR FIRST/LAST MILE PLANNING / AE115994000**A. Small Business Participation**

IBI Group made a 29.28% SBE commitment. The project is 35% complete. IBI Group is exceeding their commitment with an SBE participation of 42.58%.

Small Business Commitment	29.28% SBE	Small Business Participation	42.58% SBE
----------------------------------	-------------------	-------------------------------------	-------------------

	SBE Subcontractors	% Committed	% Participation
1.	Engineering Solutions Services	4.08%	0.23%
2.	Here Design Studio, LLC	8.68%	26.00%
3.	Terry A. Hayes Associates, Inc.	9.40%	0.00%
4.	The Robert Group, Inc.	7.12%	16.35%
Total SBE Commitment		29.28%	42.58%

B. Living Wage and Service Contract Worker Retention Policy Applicability

The Living Wage and Service Contract Worker Retention Policy (LW/SCWRP) is not applicable to this modification.

C. Prevailing Wage Applicability

Prevailing wage is not applicable to this modification.

D. Project Labor Agreement/Construction Careers Policy

Project Labor Agreement/Construction Careers Policy is not applicable to this Contract. Project Labor Agreement/Construction Careers Policy is applicable only to construction contracts that have a construction contract value in excess of \$2.5 million.

**Board Report**

File #: 2019-0850, **File Type:** Agreement**Agenda Number:** 15.

**PLANNING AND PROGRAMMING COMMITTEE
JANUARY 15, 2020****SUBJECT: ALAMEDA CORRIDOR-EAST (ACE) PROGRAM FUNDING PLAN UPDATE****ACTION: APPROVE RECOMMENDATIONS****RECOMMENDATION**

AUTHORIZE the CEO to amend the ACE funding agreement to increase Metro's contribution by \$15,000,000 (5.5% increase to the 2007 amount of \$274,323,220) for a new total amount of \$289,323,220 and program \$19,453,420, which includes previously committed funding. Metro will not participate in any future project cost increases or overruns.

ISSUE

The San Gabriel Valley Council of Governments (SGVCOG) plans to seek a programming of State Prop 1B funds in January 2020 and an allocation of SB1 Trade Corridor Enhancement Program (TCEP) funds in June 2020 from the California Transportation Commission (CTC) for the two final ACE grade separations. To do so, the SGVCOG needs to demonstrate that 1) there is a 1:1 match for the Prop 1B funds; and 2) both projects are fully funded and identify all funding sources by March 2020 for the TCEP funds. Metro's contribution to the ACE Project (Project), which has historically equaled 17 percent of the total Project cost, has been an integral element of the local funding for delivering the Project. The Metro Board most recently approved a revised Metro 17 percent contribution in November 2007 and since then various factors, including cost escalation for right-of-way and capital construction over the last decade, and scope changes have increased the total cost.

With a Board adoption of the Measure R and Measure M Cost Management Policy (Policy) in July 2018, and given the Project receives Measure R funds, staff applied the Policy to evaluate the cost increase and potential strategies available to close the funding gap. As such, Metro Board approval of the revised Project cost and associated Metro contribution amount is needed to address this cost increase and demonstrate a fully funded plan for the two projects to allow SGVCOG to secure a fund allocation from the CTC and move the projects into the construction phase as scheduled.

BACKGROUND

Metro and SGVCOG (previously ACE) entered into a funding agreement in July 1998 to support construction of a series of rail-highway grade separation and at-grade safety projects constituting the Alameda Corridor-East Project.

In June 1999 (item #42), the Metro Board approved its commitment to contribute a maximum of 17 percent , or \$161,500,000 based on the Project cost of \$950,000,000, and not participate in any cost increases or overruns. In November 2007 (Item #6), the Board approved an additional increase in Metro's contribution amount to a total of \$274,323,220 to reflect the revised Project cost at \$1,613,666,000. Since then, \$269,869,800 of the Metro contribution amount has been programmed for ACE projects, with a remaining unprogrammed balance of \$4,453,420.

Since 2007, various factors, including scope changes to projects and increased right-of-way and capital construction costs, have resulted in an increase in the Project cost to \$1,765,540,000. As identified in Attachment A, the maximum Metro contribution based on the revised Project cost would be \$300,141,800 with net increase of \$25,818,580. However, SGVCOG is requesting a maximum Metro contribution of \$289,323,220 with a net increase of \$15,000,000.

SGVCOG has been successful in securing the 83 percent of match funding for all projects delivered to date, as required under the agreement with Metro. The sources for these funds include federal, state, and private funds. Measure R was also approved in 2008, and this provides \$400 million of funding for the ACE project that is included as match funding.

In May 2018, the CTC adopted the 2018 TCEP, which included an award of \$49,000,000 in TCEP for Montebello Boulevard Grade Separation and \$29,000,000 for Turnbull Canyon Road Grade Separation projects. These TCEP funds are programmed in the fiscal year 2020 and require the SGVCOG to request and receive approval for fund allocation from CTC no later than June 2020. Therefore, a total of \$19,453,420, including \$15,000,000 of the recommended increase and the \$4,453,420 balance of the prior Metro contribution, is needed for immediate programming to support the allocation of the TCEP funds.

DISCUSSION

Since its inception in 1998, the San Gabriel Valley Council of Governments, Alameda Corridor-East Project has been successful in implementing and delivering construction projects to mitigate vehicle delays and collisions at rail-highway crossing to address community concerns over safety, noise, air quality, and emergency vehicle access.

The SGVCOG has delivered 12 projects to date, and eight projects are currently active. These completed projects have eliminated at-grade crossings, and improved traveler safety across the San Gabriel Valley where Union Pacific's freight mainlines move containerized cargo through a number of communities. These projects strongly support Metro's Agency Strategic Goal as they eliminate vehicle delays at at-grade crossings while freight trains travel through the area, and improve quality of life for the surrounding communities by improving safety, and eliminating noise impacts and tailpipe emissions from idling vehicles at such crossings.

Further, the SGVCOG has been highly successful in securing funding for its grade separation projects. To date, the SGVCOG has secured \$244.691 million (14%) from federal, \$744.089 million (41%) from state, and \$131.020 million (6%) from private and other sources that amount to the 83% of the Project cost. This breakdown includes Nogales Street on Union Pacific Railroad's Los Angeles

subdivision, which is not subject to Metro's contribution. This demonstrates the SGVCOG's continuous effort to seek and secure funding to realize much needed projects that enhance mobility, safety and quality of life.

Metro Board approval of the revised total project cost and revised Metro contribution will enable the TCEP funds to be allocated for the Montebello Grade Separation and Turnbull Canyon Road Grade Separation. These projects are scheduled to begin construction in FY21. SGVCOG anticipates completing the ACE Project by 2024 and will commit to not submitting future requests for additional Metro contribution. If future costs increase, SGVCOG will work in coordination with Metro staff to seek the programming of other local funds available to the subregion, such as Measure M subregional equity or goods movement funds.

Equity Platform

The ACE Program supports the Equity Platform Pillar III, Focus and Deliver, by delivering much needed grade separation projects that address impacts experienced by communities exposed to high, and growing, volumes of rail freight movements.

DETERMINATION OF SAFETY IMPACT

This Board action will further Metro's commitment to improving safety across LA County.

FINANCIAL IMPACT

Approval of this Board Action will result in an increase of Metro's contribution to the ACE Project by \$15,000,000. This action also includes the programming of \$19,453,420 as an amendment to the existing ACE Project funding agreement. Since this is a multi-year funding agreement, the Cost Center Manager and Chief Planning Officer will be responsible for budgeting the costs in future years. SGVCOG anticipates completing the ACE Project by 2024 and will commit to not submitting future requests for additional Metro contribution. If future costs increase, SGVCOG will work in coordination with Metro staff to seek the programming of other local funds available to the subregion, such as Measure M subregional equity or goods movement funds.

Impact to Budget

Funds for this action will come from Prop C 25% funds. This fund source is not eligible for bus and rail operations and capital. There are no impacts to the FY20 budget as the drawdown of the funds will commence in subsequent fiscal years starting in FY21.

The identified cost increase is for a Measure R-funded project and must be evaluated based on the Board-adopted Measure R and Measure M Unified Cost Management Policy. The intent of the Policy is to inform the Metro Board regarding potential cost increases to Measure R-funded projects and the strategies available to close any funding gaps. Pursuant to the Policy, shortfalls are to be addressed at the project level prior to evaluation for any additional resources using the following methods:

- 1) Scope reductions;

- 2) New local agency funding resources;
- 3) Value Engineering;
- 4) Other cost reductions within the same transit or highway corridor;
- 5) Other cost reductions within the same sub-region; and finally,
- 6) Countywide transit or highway cost reductions or other funds will be sought using pre-established priorities.

A detailed Policy analysis of the ACE project is included as Attachment C.

IMPLEMENTATION OF STRATEGIC PLAN GOALS

The Board approval of revised program cost for the ACE Program and associated Metro's 17 percent contribution would support Metro's Strategic Plan Goal 1) Provide high-quality mobility options that enable people to spend less time traveling, and 3) Enhance communities and lives through mobility and access to opportunity.

ALTERNATIVES CONSIDERED

The Board could choose not to approve this action. However, this is not recommended as it would result in the SGVCOG not receiving the TCEP funds that need to be allocated by June 2020. Further, this may force SGVCOG to forego both grade separation project altogether, resulting in detrimental impacts to the surrounding communities with respect to traffic safety, noise, limited emergency vehicle access and air quality.

NEXT STEPS

Upon Board approval, staff will execute an amendment to increase Metro contribution amount and program funds needed for Montebello Boulevard Grade Separation and Turnbull Canyon Road Grade Separation projects.

ATTACHMENTS

Attachment A - ACE Program Revised Cost and Funding Request

Attachment B - SGVCOG Letter of Request

Attachment C - Measure R and Measure M Unified Cost Management Policy

Prepared by: Akiko Yamagami, Manager, Countywide Planning & Development, (213) 418-3114

Michael Cano, DEO, Countywide Planning & Development, (213) 418-3010

Wil Ridder, EO, Countywide Planning & Development, (213) 922-2887

Laurie Lombardi, SEO, Countywide Planning & Development, (213) 418-3251

Reviewed by: James de la Loza, Chief Planning Officer, (213) 922-2920

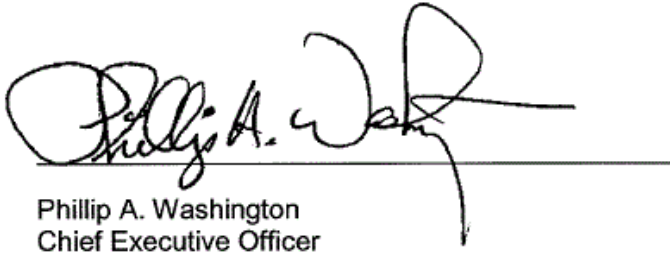

Phillip A. Washington
Chief Executive Officer

ACE Program Revised Cost and Funding Request

(\$ x 1,000)

ADDITIONAL METRO FUNDING REQUEST

ACE Projects	2019 Revised		2007 Cost Estimates		Difference	ADDITIONAL METRO FUNDING REQUEST						
	Project Cost	MTA 17%[a]	Project Cost	MTA 17%[b]		FY19	FY20	FY21	FY22	FY23	FY24	FY25
Phase 1												
Grade Crossing Improvements	34,200	5,814	35,200	5,984	(170)							
Nogales St.	49,800	8,466	53,600	9,112	(646)							
East End/Reservoir	79,000	13,430	70,800	12,036	1,394							
Ramona Blvd.	53,100	9,027	48,200	8,194	833							
Temple Ave.	55,322	9,405	63,200	10,744	(1,339)							
Temple Ave. 4th Track	39,386	6,696	17,300	2,941	3,755							
Brea Canyon	73,900	12,563	64,600	10,982	1,581							
Sunset Ave.	93,900	15,963	71,100	12,087	3,876							
Baldwin Ave.	70,400	11,968	67,000	11,390	578							
Subtotal	549,008	93,331	491,000	83,470	9,861							
Phase 2												
San Gabriel Trench	293,427	49,883	459,435	78,104	(28,221)							
Montebello Blvd.	179,954	30,592	130,769	22,231	8,361		15,000					
Puente Ave.	97,378	16,554	161,169	27,399	(10,844)							
Fairway Ave. (SP)	0	0	166,370	28,283	(28,283)							
Fairway Ave. (UP)	224,824	38,220	86,767	14,750	23,470							
Rose Hills Rd.	0	0	48,700	8,279	(8,279)							
Turnbull Canyon Rd.	99,070	16,842	69,456	11,808	5,034							
<i>Hamilton Blvd.</i>	1,800	306			306							
<i>Durfee Ave.</i>	107,841	18,333			18,333							
<i>Fullerton Rd.</i>	159,526	25,261			25,261							
<i>Maple Pedestrian Bridge</i>	25,470				0							
<i>At-Grade Montebello</i>	3,046				0							
<i>At-Grade Pomona</i>	24,196				0							
Subtotal	1,216,532	195,991	1,122,666	190,853	5,139	0	15,000	0	0	0	0	
Grand Total[c]	1,765,540	289,323	1,613,666	274,323	15,000	0	15,000	0	0	0		

Italics=New Projects

Strikethrough=Deleted Projects

NOTE: Chart omits Nogales St. (LA) project due to MTA Call for Projects funding

NOTE: Funding request amount reflects the total anticipated amount for Montebello Blvd. and Turnbull Canyon Rd. The programming request amount through this Board approval is \$19,453,420.

[a] - MTA contribution subject to a maximum of \$289,323,220; expenditures on individual projects may be reallocated subject to the MTA maximum amount.

[b] - A portion of the 2007 MTA contribution equal to \$4,453,420 has not yet been programmed by the MTA Board.

[c] - Columns may not total due to rounding.



San Gabriel Valley Council of Governments

4900 Rivergrade Rd. Ste. A120 Irwindale, CA 91706 (626) 962-9292 fax (626) 962-3552 www.theaceproject.org



December 13, 2019

Mr. Phillip A. Washington,
 Chief Executive Officer
 Los Angeles County Metropolitan Transportation Authority
 One Gateway Plaza
 Mail Stop 99-25-1
 Los Angeles, CA 90012-2952

Re: Approval of increased ACE Project budget and match funding

Dear Mr. Washington:

The San Gabriel Valley Council of Governments (SGVCOG) hereby requests Los Angeles County Metropolitan Transportation Authority (Metro) approval of the updated Alameda Corridor-East (ACE) Project budget cost estimate as well as the programming of additional Metro match funding for the Project pursuant to the prior funding agreements made between Metro and the SGVCOG.

Metro's contribution of 17 percent in Proposition C funds to the Project budget was approved by the Metro Board in June 1999, upon initiation of the Project. The Metro Board subsequently approved the updated Project budget cost estimate in November 2007 along with a revised commitment of Prop C match funds. Since then, scope changes to the overall Project were approved in 2011 by the SGVCOG Governing Board in response to an ACE Phase II study prioritizing the remaining projects based on vehicle delay, constructability and crossing collision factors. As a result, three grade separations were deleted and the Durfee Avenue grade separation project in the City of Pico Rivera (currently under construction) was added to the Project.

Active ACE Projects (Not Yet In Construction)							
Improvement Project / City	Cost Est. (\$mil.)	Daily Vehicle-Hrs. Delay (2025)	Daily Train / AADT Counts	Collisions (10 yrs. / Total)	Fatalities / Injuries	Current Phase	Construction Schedule Est.
Montebello Blvd. underpass* / Montebello	\$180.0	43.5	43 / 21,692	2 / 5	3 / 1	ROW / Final Engineering	2021-2024
Turnbull Canyon Rd. overpass** / Industry-Hacienda Heights	\$99.1	38.9	47 / 12,892	4 / 14	3 / 3	ROW / Final Engineering	2021-2023
At-grade safety measures at three crossings / Montebello	\$3.0	N/A	43 / N/A	2 / 3	0 / 1	ROW / Final Engineering	2020-2021
Maple Ave. pedestrian bridge / Montebello	\$25.5	N/A	43 / N/A	0 / 2	0 / 0	ROW / Final Engineering	2020-2021
Five crossings at-grade pedestrian safety / Pomona	\$24.2	N/A	81 / N/A	5 / 32	19 / 9	ROW / Final Engineering	2020-2021

* Additional Prop C needed as local match for \$18.8 million in State Prop 1B funds and \$49 million in State SB1 funds.
 **Additional Prop C needed as local match for \$29 million in State SB1 funds.

With this ACE program scope revision as well as increases in construction costs and real estate costs since 2007, the overall total ACE program cost has increased to \$1,765,540,000¹. If approved, the Metro contribution toward the Project would increase by \$15,000,000, or 5.5 percent more than the 2007 amount, for a total of \$289,323,220. With this submittal, however, we are requesting approval of the programming of \$19,453,420 of Prop C or other eligible funds for which the SGVCOG has secured the required 83 percent match in non-Metro funds. The programming request includes a \$4,453,420 balance of Metro's existing contribution that has not yet been programmed. The SGVCOG anticipates completing the ACE Project by 2024 and will commit to not submitting future requests for additional Metro contribution. If future costs increase, the SGVCOG will work in coordination with Metro staff to seek the programming of other local funds available to the subregion, such as Measure M subregional equity or goods movement funds.

We are aware of Metro's uniform cost management policy relating to cost increases on Measure R-funded projects and have undertaken the requirements of the policy, including evaluating value engineering, the use of local funding, and de-scoping the project. The ACE Project scope has been reduced as described above and SGVCOG has conducted formal Value Engineering Reviews on all ACE projects remaining. In accordance with Caltrans design guidelines, reviews were performed at the 35 percent design level and all cost and constructability recommendations are incorporated in the final design. Cost controls have also been exercised during construction. For example, nearly \$114 million in State Proposition 1B fund savings from the construction phase of the San Gabriel Trench project were or will be programmed for construction of additional ACE projects. We believe our reduced and capped request for additional Metro regional funds (the Prop C) demonstrates our commitment to utilize local San Gabriel Valley funding for the project.

The SGVCOG has vigorously pursued new sources of State, Federal and railroad funding for the ACE projects as match for the Metro Prop C funds, most recently securing the programming of \$78 million in new State SB 1 funds in 2018 and \$15 million in State Section 190 Grade Separation program funds this year. The Prop C funds will help provide required match for these SB 1 funds which must be approved by the California Transportation Commission (CTC) no later than June 2020 for allocation to the construction phase of the final two ACE grade separation projects. In addition, the timely commitment by Metro of additional Prop C funds is needed to provide a 1:1 match for \$18.8 million in State Prop 1B savings to be programmed for the Montebello Boulevard project at the next CTC meeting on January 29-30, 2020.

We appreciate Metro's longtime and strong partnership with the SGVCOG in funding the ACE Project for the benefit of the San Gabriel Valley and Los Angeles County. Transmitted with this letter is a SGVCOG staff report dated November 21, 2019 regarding the ACE Project revised

¹ The cost of the Nogales Street (Los Angeles Subdivision) grade separation project is omitted from the calculation of the ACE Project budget because it is the sole ACE project that was provided Metro Call for Projects funding when under the supervision of the Los Angeles County Department of Public Works. With the commitment by Metro of Prop C 17 percent match, the ACE grade separations have been excluded from Call for Projects funding.

cost. Questions regarding this matter may be directed to me or to Government and Community Relations Director Paul Hubler at (626) 373-2685 or [phubler@sgvcog.org](mailto:p hubler@sgvcog.org).

Sincerely,



Mark Christoffels
Chief Engineer

Enclosure: SGVCOG staff report dated November 21, 2019 regarding ACE Project budget

cc: Mr. Wil Ridder
Mr. Michael Cano
Ms. Akiko Yamagami

REPORT

DATE: November 21, 2019

TO: SGVCOG Governing Board Members and Alternates

FROM: Marisa Creter, Executive Director

RE: **REVISED ACE PROJECT BUDGET ESTIMATES**

RECOMMENDED ACTIONS

Adopt Resolution 19-47 approving the revised cost estimate for the ACE Project to \$1.8 billion.

SUMMARY

Given that it has been twelve years since the project cost was updated, staff felt it appropriate for the Governing Board to formally approve the current cost estimate of \$1.8 billion. The cost increase from the 2007 adopted cost estimate of \$1.4 billion is based on the following factors:

1. **Construction cost inflation.** Since 2007 construction costs have increased 34%. The past two years have seen bid increases up to 20% over estimated costs as was witnessed with the recent opening of bids for the Gold Line and the Durfee Road Grade Separation Project. Staff has projected out to the anticipated completion year of 2024 for the remaining ACE projects as well as incorporating actual bids received for projects completed or currently under construction and revised the overall estimated project cost.
2. **Real Estate.** After the recession of 2008 when real estate prices fell, the real estate market re-bounded and costs for real estate acquisitions in the past three years have gone up significantly, especially in the commercial land uses.
3. **Project scope changes.** In 2011, the Governing Board approved an ACE Project Phase II study which updated the original ACE project study done in 1997. This study added the Durfee Avenue Grade Separation Project which was not included in the original Phase I study.

When combined, the above factors have increased the total estimated costs for the ACE Program from \$1.4 billion to \$1.8 billion. A breakdown of the individual project costs is shown in Attachment A attached to this report.

BACKGROUND

The ACE Project cost was adopted by the San Gabriel Valley Council of Governments in 1997 at \$950 million in 1997 dollars. The schedule called for the project to be fully funded by June 2004

REPORT

and completed by 2008. On February 2007 the Governing Board adopted a revised cost estimate of \$1.4 billion which reflected a revised completion date of 2014 and the following factors:

1. **Inflation** - The 1997 cost estimate did not include inflation allowances. While the rate of construction inflation in the early years of the project was relatively modest, it had increased by 113% for the year 2007.
2. **Agency Overhead** - The original cost estimates did not provide for agency overhead. Since the project had no source of revenue other than project funding, additional costs were added.
3. **UPRR Force Account** - Track and signal system reconstruction on the operating railroad, as well as flagging protection, must be performed by the UPRR and is only done on a fully reimbursable basis. The original project cost estimate severely underestimated these costs.
4. **Real Estate/Relocation** - The original cost estimate did not anticipate the increase in real estate costs.
5. **Scope Changes** – As projects were refined from their concepts presented in 1997, costs were adjusted to reflect these design changes.

Given that it has been twelve years since the project cost was updated, staff felt it appropriate for the Governing Board to formally approve a revised estimated cost estimate of \$1.8 billion as outlined in the Summary Section above.

BUDGET IMPACT

The current adopted ACE Program has secured \$1,818,519,000 in funding as shown in Attachment B. Funds committed do not reflect value of properties held by the agency, pending UPRR contributions, Section 130 funding, Measure M funding, or additional Prop C match funds from Metro that staff is currently working on. Current projected costs are \$1,886,312,000. Staff believes with these additional funds the current \$67 million ACE Program funding gap can be closed.

Prepared by: 
Mark Christoffels
Chief Engineer

Approved by: 
Marisa Creter
Executive Director

ATTACHMENTS

- Attachment A – Individual ACE Project Estimates
- Attachment B – ACE Project Secured Funding
- Attachment C – Resolution 19-47

Attachment A
(shown in \$ millions)

<u>Active ACE Projects</u>		<u>Completed ACE Projects</u>	
At-Grade Pomona	\$ 24,196	Baldwin Ave.	\$ 70.400
Durfee Ave.	\$ 107.841	Brea Canyon Rd.	\$ 73.900
Fairway Dr.	\$ 224.824	Safety Crossings/IRRIS	\$ 34.200
Fullerton Rd.	\$ 159.526	East End/Reservoir St.	\$ 79.000
Montebello Blvd	\$ 179.954	Hamilton Blvd.	\$ 1.800
Turnbull Cyn. Rd.	\$ 99.070	Nogales St. (Alh.)	\$ 49.800
Maple Ave Ped Bridge	\$25.470	Nogales St. (LA)	\$ 120.772
At Grade Montebello	\$3.046	Ramona Ave.	\$ 53.100
		Sunset Ave.	\$ 93.900
		Puente Ave.	\$ 97.378
		San Gabriel Trench	\$ 293.427
		Temple Ave.	\$ 94.708
		<i>Total Cost of Projects:</i>	\$ 1,886.312

Attachment B
(shown in \$ millions)

Federal	\$ 244.691
State	\$ 744.089
MTA	\$ 698.719
Other	\$ 131.020

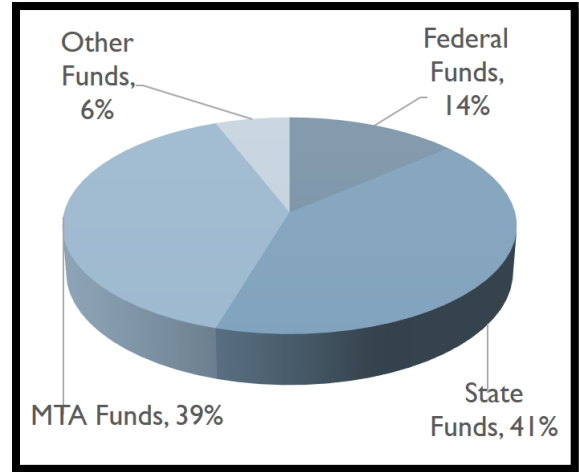

Total funds committed: \$ 1,818.519

Attachment C

Resolution No. 19-47

Page 1 of 3

RESOLUTION NO. 19-47

**A RESOLUTION OF THE GOVERNING BOARD OF THE SAN
GABRIEL VALLEY COUNCIL OF GOVERNMENTS (SGVCOG)
APPROVING THE REVISED ACE PROJECT BUDGET**

WHEREAS, the ACE Project estimates of \$1.4 billion were approved on February 12, 2007; and

WHEREAS, cost estimates are updated periodically to reflect current factors and trends; and

WHEREAS, the revised cost estimates have increased due to construction cost inflation, real estate and project scope changes.

NOW, THEREFORE, the Governing Board of the SGVCOG hereby approves the \$1,886.312 million total revised ACE Project budget estimates as shown in Exhibit A.

PASSED AND ADOPTED by the Governing Board of San Gabriel Valley Council of Governments, in the County of Los Angeles, State of California, on the 21st day of November 2019.

San Gabriel Valley Council of Governments

Cynthia Sternquist, President

Resolution No. 19-47

Page 2 of 3

Attest:

I, Marisa Creter, Executive Director and Secretary of the Board of Directors of the San Gabriel Valley Council of Governments, do hereby certify that Resolution 19-47 was adopted at a regular meeting of the Governing Board held on the 21st day of November 2019 by the following vote:

AYES:	
NOES:	
ABSTAIN:	
ABSENT:	

Marisa Creter, Secretary

Exhibit A
(shown in \$ millions)

<u>Active ACE Projects</u>		<u>Completed ACE Projects</u>	
At-Grade Pomona	\$ 24,196	Baldwin Ave.	\$ 70.400
Durfee Ave.	\$ 107.841	Brea Canyon Rd.	\$ 73.900
Fairway Dr.	\$ 224.824	Safety Crossings/IRRIS	\$ 34.200
Fullerton Rd.	\$ 159.526	East End/Reservoir St.	\$ 79.000
Montebello Blvd	\$ 179.954	Hamilton Blvd.	\$ 1.800
Turnbull Cyn. Rd.	\$ 99.070	Nogales St. (Alh.)	\$ 49.800
Maple Ave Ped Bridge	\$25.470	Nogales St. (LA)	\$ 120.772
At Grade Montebello	\$3.046	Ramona Ave.	\$ 53.100
		Sunset Ave.	\$ 93.900
		Puente Ave.	\$ 97.378
		San Gabriel Trench	\$ 293.427
		Temple Ave.	\$ 94.708
		<i>Total Cost of Projects:</i>	\$ 1,886.312

Alameda Corridor East (ACE)

Measure R and Measure M Unified Cost Management Policy Analysis

Introduction

The Measure R and Measure M Unified Cost Management Policy (the Policy) was adopted by the Metro Board of Directors in June 2018. The precursor Measure R cost management policy was adopted in March 2011. The intent of the Policy is to inform the Metro Board of Directors regarding potential cost increases to Measure R- and Measure M-funded projects and the strategies available to close any funding gaps. The Alameda Corridor East Project (the Project) is subject to this policy analysis.

The Project budget (also referred to as the Project cost) was last approved by the Board in November 2007 at \$1,765,540,000 with Metro's contribution equal to \$274,323,220. ACE has requested that Metro increase its contribution by \$15,000,000 to \$289,323,220. This analysis recommends trade-offs required by the Policy to identify the funds necessary to meet the cost increase.

Measure R and Measure M Unified Cost Management Policy Summary

The adopted Policy stipulates the following:

If a project cost increase occurs, the Metro Board of Directors must approve a plan of action to address the issue prior to taking any action necessary to permit the project to move to the next milestone. Increases will be measured against subsequent actions on cost estimates taken by the Metro Board of Directors, including the determination of the budget. Shortfalls will first be addressed at the project level prior to evaluation for any additional resources using these methods in this order as appropriate:

- 1) Scope reductions;
- 2) New local agency funding resources;
- 3) Value Engineering;
- 4) Other cost reductions within the same transit or highway corridor;
- 5) Other cost reductions within the same sub-region; and finally,
- 6) Countywide transit or highway cost reductions or other funds will be sought using pre-established priorities.

Scope Reductions

According to ACE staff from the San Gabriel Valley Council of Governments (SGVCOG), the scope of the Project was reduced in 2011 by the SGVCOG Governing Board based on a study that prioritized the remaining grade separation projects. As a result, three grade separations were deleted and a Durfee Avenue grade separation project in the City of Pico Rivera (currently under construction) was added. Because of this overall reduction in project scope, we recommend moving to the next step.

New Local Agency Funding Resources

The Project is located in the San Gabriel subregion and Gateway Cities subregion (as defined in the Policy). The Project is eligible for funding from cities in the region, including Measure R and Measure M local return and the Local Streets and Roads program (also known as the gas tax subvention, as expanded by SB 1 statewide fuel taxes). However the SGVCOG has not pursued city funding for the yet-to-be-completed grade separation projects and the potential for obtaining any city funding is uncertain and would delay the receipt of grant funding and start of construction.

The subregions do receive funding through the Multi-year Subregional Programs (MSP) identified in the Measure M Ordinance. The San Gabriel subregion has a \$33,000,000 Goods Movement MSP that is likely eligible for the Project; however, these funds are not available for construction (per the Expenditure Plan) until FY 2048 and would need to be traded with other MSP funds that are available now. Further, the MSP funding is only programmed in one year increments by Metro, per Board guidelines, and the subregion would need some form of leveraging of the funds to make funds available for the current or any future cost increase. The Project is also eligible for the Subregional Equity Program MSP that has \$199,000,000 of funding for San Gabriel and \$244,000,000 for Gateway Cities. San Gabriel (through SGVCOG and Foothill Construction Authority separate action) has already committed \$126,000,000 of this program to the Gold Line extension to Pomona. Nevertheless, the SCVCOG has committed via a December 2019 letter to Metro a future MSP contribution to the Project, if needed for any additional costs.

Value Engineering

The SGVCOG has communicated to Metro that it has conducted formal Value Engineering Reviews on all remaining ACE projects. In accordance with Caltrans design guidelines, reviews were performed at the 35 percent design level and all cost and constructability recommendations are incorporated in the final design. Cost controls have also been exercised during construction. Nearly \$114 million in State Proposition 1B fund savings from the construction phase of the San Gabriel Trench project were or will be programmed for construction of additional ACE projects. As a result, we recommend moving to the next step.

Other Cost Reductions within the Same Transit or Highway Corridor, or within the Same Sub-region

This step refers to potential cost reductions on related Measure R and Measure M projects in the Expenditure Plan. We have not identified projects along the Union Pacific and/or Metrolink corridor that are related to the ACE project that could be reduced or eliminated to fund the shortfall. There are also no projects that have existing or potential savings that could be transferred.

Countywide Cost Reductions and/or Other Funds

The ACE corridor has previously been designated as a “project of national and regional significance” by the FHWA due to its impact on the national and regional economy.

Because of this, we recommend that any remaining funding shortfall for the Project be dealt with at the Countywide level.

The Project is eligible for Proposition C 25% Transit-Related Streets and Highways funding and this source has been used in the past for Metro's contribution, in addition to the \$400,000,000 allocated to the Project in the Measure R Expenditure Plan. The Proposition C 25% funds are recommended to address the \$15,000,000 increase in the Project budget.



**Next stop: shaping our goods
movement system together.**

**Alameda Corridor-East (ACE) Program Funding Plan Update
Planning & Programming Committee, Item No. 15
January 15, 2020**



Metro

Historical Background on Metro Contributions

Date	Board Approved Metro Funding Amount (\$ millions)	Action	Notes	Total ACE Project Cost (\$ millions)	Funding Sources
MOU4367 & MOU8002					
May 1999	\$14.14*	1997 Call for Projects			Prop C
Oct. 2002	\$161.50*	June 1999 Metro Board Action	Board approval of Metro's 17% contribution to the total project cost	\$950.00	Prop C and RIP
Nov. 2007	\$274.32*	November 2007 Metro Board Action	Board approval of updated total ACE Program cost and updated Metro's 17% contribution	\$1,613.67	Prop C
* Metro funding amount listed in later years includes previously approved amount. The last Board approved 17% contribution under MOU8002 is \$274.32 million.					
MOU8002R					
March 2010	\$42.00	June 2009 Board Action	For San Gabriel Trench Project	\$1,613.67	Measure R
May 2013	\$358.00	May 2013 Board Action	Board approval of ACE Measure R Expenditure Plan	\$1,613.67	Measure R



Urgency of the Fund Request

- SGVCOG plans to seek programming of State Prop 1B funds (TCIF) in January 2020
 - TCIF funds require 1:1 match demonstration.
 - These funds are cost savings garnered from the delivery of previous ACE grade separation projects.
 - If not programmed by June 2020, the funds will no longer be available.
- SB1 2018 Trade Corridor Enhancement Program (TCEP) funds need to be programmed by June 2020
 - TCEP funds were awarded to Montebello Blvd. and Turnbull Canyon Road grade separation projects as part of Metro-sponsored joint application with ACE and Ports of LA and Long Beach.



Measures R and M

Unified Cost Management Policy Analysis

Scope Reductions

- The SGVCOG Governing Board reduced the Project scope in 2011 based on a prioritization study for the remaining grade separation projects.

New Local Agency Funding Resources

- The Multi-year Subregional Programs (MSP) will not be available until **FY2048**.

Value Engineering

- The SGVCOG has applied Caltrans design guidelines to capitalize on value engineering and cost controls to save nearly \$114 million.

Countywide Cost Reductions and/or Other Funds

- The ACE Project has been designated as a “project of national and regional significance” by the FHWA.

Therefore, staff recommends that remaining funding shortfall be dealt with at the countywide level.

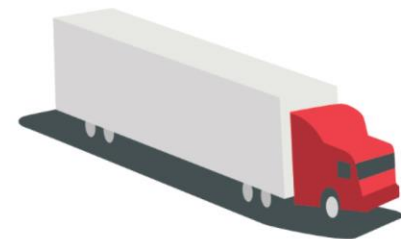

Other Considerations

- The SGVCOG has secured over **80%** of the Project funds from other sources.
- If SGVCOG were to request an updated Metro 17% contribution based on the current total ACE Project cost, it would be \$25.82 million.
 - Instead, SGVCOG is requesting \$15 million needed to complete the final grade separation projects.

(\$ in 000)		17% Contribution
Current Total ACE Project Cost	\$1,765,540	\$300,142
2007 Total ACE Project Cost	\$1,613,666	\$274,323
	Difference	\$25,819

ACE Additional Funding Request	\$15,000
---------------------------------------	-----------------

- The SGVCOG has delivered **12 projects** to date with **eight projects** currently active.
- If future costs increase, SGVCOG will work with Metro staff to seek programming of other local funds available to the subregion.

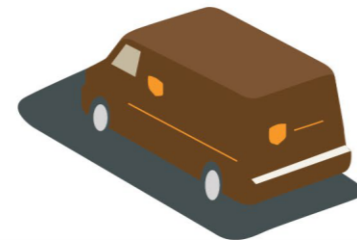

Recommendation

Authorize the CEO to amend the ACE funding agreement to increase Metro's contribution by \$15,000,000 for a new total amount of \$289,323,220 and program \$19,453,420, which includes previously committed funding. Metro will not participate in any future project cost increases or overruns.





Board Report

File #: 2019-0795, File Type: Contract

Agenda Number: 17.

FINANCE, BUDGET AND AUDIT COMMITTEE JANUARY 15, 2020

SUBJECT: RISK MANAGEMENT INSURANCE BROKERAGE SERVICES

ACTION: APPROVE CONTRACT AWARD

RECOMMENDATION

AUTHORIZE the Chief Executive Officer to award a five-year, firm fixed price Contract No. PS63853000 to USI Insurance Services LLC in the amount of \$1,268,600 for a five-year base term, \$530,503 for the first 2-year option, and \$562,811 for the second 2-year option, for a combined total amount of \$2,361,914, effective June 1, 2020 subject to resolution of protest(s), if any.

ISSUE

Metro's current brokerage services contract with USI Insurance Services LLC ("USI"), expires on May 31, 2020.

BACKGROUND

An insurance broker of record is required for Metro to purchase insurance from commercial markets. Insurance is necessary because it covers risks such as potentially catastrophic property and liability damages that are better managed through commercial insurance. Additionally, many of our contracts and other agreements require commercial insurance coverage.

DISCUSSION

Metro uses a licensed broker to purchase insurance for its non-construction exposures. The broker markets Metro's excess liability insurance (\$300 million in limits with \$8 million self-insured retention), all risk property and flood coverage, (\$400 million in limits, no earthquake and varying deductibles), drone insurance, and railroad liability insurance (\$60 million in limits currently which is adjusted every three years based on Consumer Price Index). The broker has also handled major insurance project specific umbrella insurance (up to \$300 million historically) as well other coverages such as pollution legal liability, owner's protective, fraud and fidelity, and public official's directors and officers. Currently, Metro's total excess liability and property insurance premiums are about \$9.1 million per year.

In addition to handling required marketing and placement of coverage, the broker reviews contracts to determine appropriate insurance requirements, insurance coverage placed by contractors to ensure compliance with contract terms and gives Metro staff expert advice on insurance matters including construction insurance coverage matters. The broker also provides insurance guidance on Measure M and R construction projects including Regional Connector, Westside Subway Extensions, Crenshaw Transportation Corridor, Gold Line Foothill Extensions and others.

DETERMINATION OF SAFETY IMPACT

Approval of this recommendation will not impact the safety of Metro's patrons or employees.

FINANCIAL IMPACT

The funding of \$172,025 for the remainder of this fiscal year is included in the FY20 budget in cost center 0531, Risk Management - Non-Departmental under various project numbers, account 50316 - Professional Services.

Since this is a multi-year contract, the cost center manager and the Chief Risk, Safety and Asset Management Officer will be responsible for budgeting this expense in future years.

Impact to Budget

The current year funding for this action will come from a combination of bus and rail operating funds. No other sources of funds were considered for this activity because the insurance coverage placed by the broker protects the agency against operational losses.

IMPLEMENTATION OF STRATEGIC PLAN GOALS

Recommendation supports strategic plan goal # 5 "Provide responsive, accountable and trustworthy governance within the LA Metro organization." The responsible administration of Metro's insurance and claims administration programs requires the use of proficient insurance brokers and actuaries.

ALTERNATIVES CONSIDERED

The Board may elect not to approve the new contract. However, this action is not recommended because the fee proposed by USI represents the most competitive fee for services provided by the marketplace. Further, as USI is also the current broker of record for the agency, the addition of the nine-year term allows us to build upon the existing relationship and lock in the pricing advantage of today's highly competitive brokerage environment.

NEXT STEPS

Upon Board approval, staff will execute Contract No. PS63853000 to USI Insurance Services LLC for brokerage services, effective June 1, 2020.

ATTACHMENTS

Attachment A - Procurement Summary

Attachment B - DEOD Summary

Prepared by: Tim Rosevear, Manager, Risk Financing, (213) 922-6354

Reviewed by: Kenneth Hernandez, Chief Risk, Safety and Asset Management Officer, (213)
922-2990

Debra Avila, Chief, Vendor/Contract Management Officer, (213) 418-3051

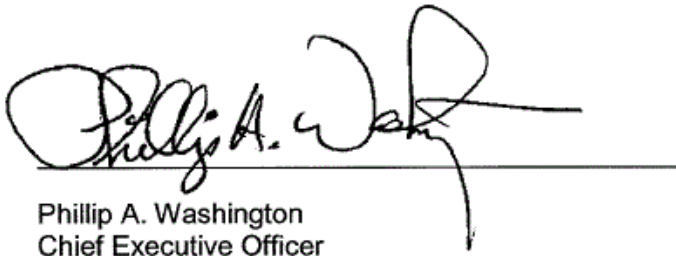

Phillip A. Washington
Chief Executive Officer

PROCUREMENT SUMMARY

RISK MANAGEMENT INSURANCE BORKERAGE SERVICES

1.	Contract Number: PS63853000	
2.	Recommended Vendor: USI INSURANCE SERVICES LLC	
3.	Type of Procurement (check one): <input type="checkbox"/> IFB <input checked="" type="checkbox"/> RFP <input type="checkbox"/> RFP-A&E <input type="checkbox"/> Non-Competitive <input type="checkbox"/> Modification <input type="checkbox"/> Task Order	
4.	Procurement Dates:	
	A. Issued: August 12, 2019	
	B. Advertised/Publicized: August 12, 2019	
	C. Pre-Proposal Conference: August 28, 2019	
	D. Proposals Due: September 16, 2019	
	E. Pre-Qualification Completed: Pending	
	F. Conflict of Interest Form Submitted to Ethics: December 3, 2019	
	G. Protest Period End Date: 1/20/20	
5.	Solicitations Picked up/Downloaded: 30	Bids/Proposals Received: 4
6.	Contract Administrator: Marc Margoni	Telephone Number: (213) 922-1304
7.	Project Manager: Tim Rosevear	Telephone Number: (213) 922-6354

A. Procurement Background

This Board Action is to approve the award of Contract No. PS63853000 to USI Insurance Services LLC to provide insurance brokerage services. Board approval of contract awards are subject to resolution of any properly submitted protest.

On August 12, 2019, Request for Proposal (RFP) No. PS63853 was issued in accordance with Metro's Acquisition Policy. The contract type is firm fixed price. This RFP was issued with a DBE goal of 15%.

One amendment was issued during the solicitation phase of this RFP:

- Amendment No. 1, issued on September 10, 2019 extended the proposal due date.

A pre-proposal conference was held on August 28, 2019, and was attended by eight participants representing six firms. There were 40 questions received and responses were provided prior to the proposal due date. A total of 30 firms downloaded the RFP and were included on the plan holders list.

A total of four proposals were received on September 16, 2019 from firms listed below in alphabetical order:

- Alliant Insurance Services, Inc.
- Aon Risk Insurance Services West, Inc.

- Arthur J. Gallagher & Co., Insurance Brokers of California, Inc.
- USI Insurance Services LLC

B. Evaluation of Proposals

A Proposal Evaluation Team (PET) consisting of staff from Risk Management and San Diego Metropolitan Transit System (MTS), was convened and conducted a comprehensive technical evaluation of the proposals received.

On October 8, 2019, the PET met to review the evaluation criteria package, process confidentiality and conflict of interest forms and take receipt of the four proposals to initiate the evaluation phase. Evaluations were conducted from October 8, 2019 through October 23, 2019.

The proposals were initially evaluated based on pass/fail minimum qualifications criteria to determine proposals that are “technically acceptable.” The pass/fail criteria included experience in specialized insurance coverages, experience in the public sector, and having the required insurance licenses.

Of the four proposals received, Aon Risk Insurance Services West, Inc. was deemed non-responsive for failure to meet the DBE goal. The remaining three proposals were deemed technically acceptable and were further evaluated based on the following weighted evaluation criteria:

- | | |
|--|------------|
| • Qualification of Key Personnel Assigned | 35 Percent |
| • Qualifications of Contractor | 35 Percent |
| • Commission Rate Earned on Major Construction Umbrella Policies | 10 Percent |
| • Brokerage Cost Proposal | 20 Percent |

Several factors were considered in developing these weights, giving the greatest importance to both the qualifications of key personnel assigned and the qualifications of the contractor.

Qualification Summary of Firms:

Alliant Insurance Services, Inc.

Founded in 1925, Alliant Insurance Services, Inc. (Alliant) is headquartered in Newport Beach, CA. It is a nationwide distributor of diversified insurance products and services. Operating through a national network of offices, Alliant offers a comprehensive portfolio of services including risk solutions, employee benefits, co-brokered solutions, risk control consulting and property valuation.

Arthur J. Gallagher & Co., Insurance Brokers of CA, Inc.

Arthur J. Gallagher & Co., Insurance Brokers of CA, Inc. is a U.S. based insurance brokerage and risk management services firm with principal place of business in Rolling Meadows, Illinois. The firm was established in 1927 and is one of the largest insurance brokers in the world. It provides personal, commercial, surety, life, health, and long-term care insurance solutions for individuals, families, and businesses.

USI Insurance Services LLC:

Founded in 1994 Insurance Services LLC (USI) provides integrated distribution of general and specialty property and casualty insurance, as well as financial services including employee benefits outsourcing and related consulting. USI has served over 150,000 clients covering several industry sectors. Within the public sector, USI handles all lines of property/casualty insurance, employee benefits and bonds. Clients include Metropolitan Transit Authority of Harris County, San Joaquin Regional Transit District, Utah Department of Transportation and the Cities Atlanta, Chicago, Dallas, Charlotte and San Antonio.

On October 23, 2019, the PET reconvened and USI Insurance Services LLC was determined to be the top ranked firm.

The following is a summary of the PET Scores:

1	Firm	Average Score	Factor Weight	Weighted Average Score	Rank
2	USI Insurance Services, LLC				
3	Qualification of Key Personnel Assigned	91.69	35.00%	32.09	
4	Qualifications of Contractor	89.00	35.00%	31.15	
5	Commission Rate Earned on Major Construction Umbrella Policies	100.00	10.00%	10.00	
6	Brokerage Cost Proposal	81.70	20.00%	16.34	
7	Total		100.00%	89.58	1
8	Alliant Insurance Services, Inc.				
9	Qualification of Key Personnel Assigned	89.20	35.00%	31.22	
10	Qualifications of Contractor	91.34	35.00%	31.97	
11	Commission Rate Earned on Major Construction Umbrella Policies	100.00	10.00%	10.00	
12	Brokerage Cost Proposal	71.50	20.00%	14.30	
13	Total		100.00%	87.49	2

14	Arthur J. Gallagher & Co., Insurance Brokers of CA, Inc.				
15	Qualification of Key Personnel Assigned	86.69	35.00%	30.34	
16	Qualifications of Contractor	83.66	35.00%	29.28	
17	Commission Rate Earned on Major Construction Umbrella Policies	75.00	10.00%	7.50	
18	Brokerage Cost Proposal	100.00	20.00%	20.00	
19	Total		100.00%	87.12	3

C. Cost/Price Analysis

The recommended price has been determined to be fair and reasonable based upon adequate price competition, price analysis, technical analysis, fact finding, and historical costs. The recommended price is lower than Metro's independent cost estimate (ICE). Metro's ICE included a three percent rate of inflation for each year during the period of performance, inclusive of the option periods, while the proposed price included an escalation rate for the option periods only.

	Proposer Name	Proposal Amount	Metro ICE	Negotiated or NTE amount
1.	USI Insurance Services	\$2,361,914	\$4,063,642	\$2,361,914
2.	Alliant Insurance Services, Inc.	\$2,700,000		
3.	Arthur J. Gallagher & Co., Insurance Brokers of Ca, Inc.	\$1,930,050		

D. Background on Recommended Contractor

The recommended firm, USI Insurance Services LLC (USI), is headquartered in Valhalla, New York. It is one of the largest insurance brokerage and consulting firms in the world, delivering property and casualty, employee benefits, personal risk programs, and retirement solutions throughout the United States. It is a leading insurance brokerage nationwide approaching \$2 billion in revenue and over \$12 billion in premium placements.

For the past eight years, USI has been assisting Metro in identifying risk exposure, coverages and trends that are unique to a transit agency and performance has been satisfactory. USI's team includes a DBE subcontractor, Barragan Corp International, that will provide associated safety and loss control services.

The proposed Project Manager has 40 years of large account experience and is well versed in all aspects of Metro's property and casualty programs. She has worked with Metro since 2011 and has been actively involved in every facet of Metro's insurance

brokerage program including marketing, placements, coverage and policy review, contract analyses and claims advocacy.

DEOD SUMMARY

RISK MANAGEMENT INSURANCE BORKERAGE SERVICES

A. Small Business Participation

The Diversity and Economic Opportunity Department (DEOD) established a 15% Disadvantaged Business Enterprise (DBE) goal for this solicitation. USI Insurance Services made a 15% DBE commitment.

Small Business Goal	15% DBE	Small Business Commitment	15% DBE
----------------------------	----------------	----------------------------------	----------------

	DBE Subcontractors	% Committed
1.	Barragan Corp International	15%
	Total Commitment	15%

B. Living Wage and Service Contract Worker Retention Policy Applicability

The Living Wage and Service Contract Worker Retention Policy (LW/SCWRP) is not applicable to this contract.

C. Prevailing Wage Applicability

Prevailing wage is not applicable to this contract.

D. Project Labor Agreement/Construction Careers Policy

Project Labor Agreement/Construction Careers Policy is not applicable to this Contract. Project Labor Agreement/Construction Careers Policy is applicable only to construction contracts that have a construction contract value in excess of \$2.5 million.



Board Report

File #: 2019-0802, File Type: Appointment

Agenda Number: 20.

**OPERATIONS, SAFETY AND CUSTOMER EXPERIENCE COMMITTEE
JANUARY 16, 2020**

SUBJECT: MEMBERSHIP ON METRO’S REGIONAL SERVICE COUNCILS

ACTION: APPROVE NOMINATIONS

RECOMMENDATION

APPROVE nominees for membership on Metro’s San Gabriel Valley and Westside Central Service Councils.

ISSUE

A member of the San Gabriel Valley Service Council submitted her resignation effective October 24, 2020. The term of that now-vacant seat is July 1, 2018 - June 30, 2021.

A member of the Westside Central Service Council submitted her resignation effective December 11, 2020. The term of that now-vacant seat is July 1, 2019 - June 30, 2022.

DISCUSSION

Metro seeks to appoint Service Council members reflective of the demographics of each respective region. The 2016 American Community Survey demographics of the Service Council regions where these appointments are to be made as compared to the demographics of the membership of those Councils with these appointments is as follows:

Region	San Gabriel Valley		Westside Central	
	Membership	Actual	Membership	Actual
Hispanic	33.3 %	49.9%	44.4%	43.2%
White	44.4%	18.3%	22.0%	31.0%
Asian	22.2%	26.2%	11.1%	13.3%
Black	0%	3.3%	22.2%	9.3%
Other	0%	2.3%	0%	3.1%

The following individuals have been nominated to serve by the nominating authorities of the vacant seats. If approved by the Board, these appointments will serve the remainder of the seats’ three-year terms. A brief listing of the nominees qualifications and the nomination letters are provided.

San Gabriel Valley

- A. Ben Wong, San Gabriel Valley Service Council, New Appointment
Nominated by: San Gabriel Valley Council of Governments
Term Ending: June 30, 2021

The demographic makeup of the San Gabriel Valley Service Council with the appointment of this nominee will consist of three (3) Hispanic members, four (4) White members, and two (2) Asian members as self-identified by the members in terms of racial/ethnic identity. The gender breakdown of the Council will be eight (8) men and one (1) woman.

Westside Central

- A. Francisco Gomez, Westside Central Service Council, New Appointment
Nominated by: Westside Cities Council of Governments
Term Ending: June 30, 2022

The demographic makeup of the Westside Central Service Council with the appointment of this nominee will consist of four (4) Hispanic members, two (2) White members, one (1) Asian member, and two (2) Black members as self-identified by the members in terms of racial/ethnic identity. The gender breakdown of the Council will be six (6) men and three (3) women.

DETERMINATION OF SAFETY IMPACT

Maintaining the full complement of representatives on each Service Council to represent each service area is important. As each representative is to be a regular user of public transit, and each Council is composed of people from diverse areas and backgrounds, this enables each Council to better understand the needs of transit consumers including the need for safe operation of transit service and safe location of bus stops.

IMPLEMENTATION OF STRATEGIC PLAN GOALS

Approval of this recommendation supports the following Metro Strategic Plan Goal: 30 Enhance communities and lives through mobility and access to opportunity

ALTERNATIVES CONSIDERED

The alternative to approving this appointment would be for this nominee to not be approved for appointment. To do so would result in reduced effectiveness of the Service Councils, as it would increase the difficulty of obtaining the quorum necessary to allow the Service Councils to formulate and submit their recommendations to the Board. It would also result in the Service Councils having less diverse representation of their respective service area.

NEXT STEPS

Staff will continue to monitor the major contributors to the quality of bus service from the customer's perspective, and share that information with the Service Councils for use in their work to plan and to implement and improve bus service in their areas and the customer experience using our bus service.

ATTACHMENTS

Attachment A - Nominees Listing of Qualifications

Attachment B - Nomination Letters

Prepared by: Conan Cheung, Sr. Executive Officer, Service Development, Scheduling and Analysis, (213) 418-3034
Dolores Ramos, Chief Administrative Analyst, Regional Service Councils, (213) 922-1210

Reviewed by: James T. Gallagher, Chief Operations Officer, (213) 418-3108

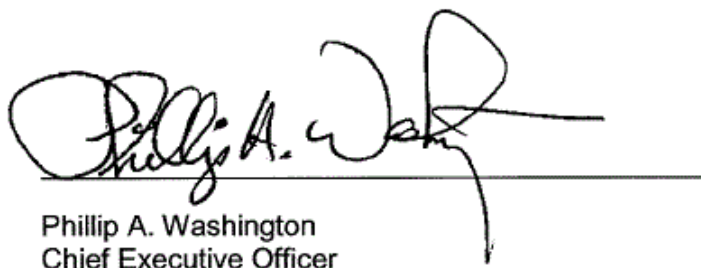

Phillip A. Washington
Chief Executive Officer

NEW APPOINTEE BIOGRAPHY AND LISTING OF QUALIFICATIONS

Ben Wong, Nominee for San Gabriel Valley Service Council



Ben Wong is a former Mayor and West Covina Councilmember. A longtime West Covina resident, Mr. Wong is the past president of the West Covina Chamber of Commerce and Executive Board president of Foothill Transit. He has also served on the boards of directors of numerous community and nonprofit organizations including West Covina Lions Club, Citrus Valley Medical Center Foundation, Mt. San Antonio College Foundation, San Gabriel Valley Economic Partnership, CAUSE (Center for Asian Americans United for Self-Empowerment), and the Institute for Local Government.

Mr. Wong currently works as a Board Consultant to a Southern California Air Quality Management District (SCAQMD) Board member, where he plans, organizing, develops, and evaluates a variety of programs, and assists stakeholders with SCAQMD grant/permit processes. His past experience includes: Executive Director for the Industry Manufacturers Council (2016-2018), Local Public Affairs Officer for Southern California Edison (2013-2015), Regional Public Affairs Manager for the League of California Cities (2006 – 2007), and Executive Director of the League of California Cities' Los Angeles County Division (2007 2010). For more than 20 years before that, Ben managed The Great Wall Restaurant, a West Covina family-owned business founded by Ben's immigrant parents in 1955. Mr. Wong is a graduate of Covina High School, and holds a Bachelor of Science degree in Biology and a Doctorate in Biochemistry from the University of Southern California (USC).

Francisco Gomez, Nominee for Westside Central Service Council



Francisco Gomez has served as a Transportation Program Administrator for the City of West Hollywood Lines since 2014. Prior to holding that position, he worked as an Administrative Specialist in the Social Services Division where he drafted a Title VI Program for the City's transportation programs. Mr. Gomez has also experience as a Planning Commissioner and Citizen's Advisory Committee Commissioner with the City of South Gate. Mr. Gomez holds a Bachelor of Arts degree in Political Science from University of California, Merced and a Master of Science in Public Administration from Cal State Los Angeles.

APPOINTING AUTHORITY NOMINATION LETTERS



November 27, 2019

OFFICERS

- President*
Cynthia Sternquist
- 1st Vice President*
Margaret Clark
- 2nd Vice President*
Becky Shelton
- 3rd Vice President*
Tim Hepburn

Ms. Dolores Ramos
Chief Administrative Analyst
1 Gateway Plaza, MS 99-7-2
Los Angeles, CA 90012

RE: Metro’s San Gabriel Valley Service Council Representative

MEMBERS

- Alhambra*
- Arcadia*
- Azusa*
- Baldwin Park*
- Bradbury*
- Claremont*
- Covina*
- Diamond Bar*
- Duarte*
- El Monte*
- Glendora*
- Industry*
- Irwindale*
- La Cañada Flintridge*
- La Puente*
- La Verne*
- Monrovia*
- Montebello*
- Monterey Park*
- Pomona*
- Rosemead*
- San Dimas*
- San Gabriel*
- San Marino*
- Sierra Madre*
- South El Monte*
- South Pasadena*
- Temple City*
- Walnut*
- West Covina*
- First District, L.A. County*
Unincorporated Communities
- Fourth District, L.A. County*
Unincorporated Communities
- Fifth District, L.A. County*
Unincorporated Communities
- SGV Water Districts*

Dear Ms. Ramos:

At their November 21, 2019 meeting, the San Gabriel Valley Council of Governments’ Governing Board appointed Ben Wong as the replacement for Valerie Gibson and will be the new representative for the San Gabriel Valley Metro Service Council position. Mr. Wong will complete the remainder of the July 1, 2018-June 30, 2021 term. Should you have any questions, please feel free to contact me at (626) 457-1800.

Sincerely,

Marisa Creter
Executive Director
San Gabriel Valley Council of Governments

cc: Ben Wong



Date: December 13, 2019

To: Dolores Ramos, Chief Administrative Analyst, Metro

From: Cecilia Estolano, WSCCOG Executive Director
Winnie Fong, WSCCOG Project Director

CC: Francisco Gomez, Transit Program Administrator, City of West Hollywood

Subject: **Westside Cities COG Re-Appointment to the Metro Westside/Central Service Council**

On November 19, 2019, the Westside Cities Council of Governments (WSCCOG) received correspondence from our Metro Westside/Central Service Council Representative Perri Sloane Goodman announcing her retirement at the City of West Hollywood at the end of this year and will be resigning from her position as the Service Council member (refer to [Attachment A](#)). This will vacate the position for a Service Council member to serve the remainder of Ms. Goodman's term from January 2020 until June 2022. In the letter, Ms. Goodman recommended Francisco Gomez, Transit Program Administrator (City of West Hollywood) to cover the remainder of her term. Mr. Gomez meets Metro's requirements for the position as a regular transit user working and/or residing in the Westside subregion. Refer to [Attachment B](#) for Mr. Gomez's letter of interest.

On December 12, 2019, the WSCCOG Board voted unanimously to appoint Mr. Gomez to serve as the WSCCOG representative to the Metro Westside/Central Service Council beginning January 2020 until June 2020.

Please accept this appointment on behalf of the WSCCOG Board. Should you have any questions regarding this matter, please contact the WSCCOG Project Director Winnie Fong at winnie@estolanoadvisors.com or at (213) 612-4545.

Service Councils Overview

Background

2003 – Established by the Metro Board to provide budgetary and operational oversight and collect community input on proposed bus service changes

2011 – Centralized and retained responsibility for conducting public hearings, and approving all changes to modify, add, and remove Metro bus service routes

Membership

- Nominated by appointing authorities and confirmed by the Metro Board (Slide 4)
- Each Council has 9 members; Members serve 3-year terms, which are staggered among members. Members can serve more than one 3-year term if reappointed by the nominating authority and confirmed by the Board
- Members must live, represent, or work in the communities within the boundaries of a designated region; should use public transit within the region they represent
- May be elected official and/or private citizen; at least 50% of each Council's members shall be regular users of public transit services

By Laws

Roles and Responsibilities

- Provide locally accessible public forums (monthly meetings & public hearings)
- Identify issues related to transit user experience, such as customer information and wayfinding, fare collection, safety, and cleanliness of vehicles and facilities
- Monitor KPIs and provide feedback for improvement
- Call and conduct public hearings for all major bus service changes
- Quarterly meetings with the Metro Chief Executive Officer and other executive staff
- Review route planning studies to improve Metro services routes and schedules
- Promote coordination of transit services (Metro, Municipal, and Local Return)

Structure

Region	Nominating Authorities
Gateway Cities	Gateway Cities Council of Governments (9)
San Fernando Valley	Cities of Burbank, Glendale, San Fernando (2) City of Los Angeles Mayor (4) LA County 3 rd District Supervisor (1) LA County 5 th District Supervisor (1) Las Virgenes-Malibu Council of Governments (1)
San Gabriel Valley	LA County 1 st District Supervisor (1) LA County 5 th District Supervisor (1) Cities of Alhambra, South Pasadena, San Gabriel, San Marino (1) Cities of Arcadia, El Monte, Temple City (1) Cities of Montebello, Monterey Park, Rosemead (1) Cities of Pasadena, Sierra Madre, La Canada Flintridge (1) San Gabriel Valley Council of Governments (3)
South Bay Cities	South Bay Cities Council of Governments (9)
Westside Central	City of Los Angeles Mayor (4) LA County 2 nd District Supervisor (1) LA County 3 rd District Supervisor (1) Westside Cities Council of Governments (3)

Composition

	LA County 2019	All Councils Avg 2019	All Councils Avg 2013
Hispanic	48.7%	42.2%	27.8%
White	25.6%	37.8%	52.2%
Asian	14.4%	8.9%	6.7%
Black	8.3%	8.9%	8.9%
Other Race	2.9%	0%	2.2%
Male	49.7%	68.89%	74.17%
Female	50.3%	31.11%	25.83%
Age	36 yrs	52.91 yrs	55.30 yrs



Board Report

File #: 2019-0861, File Type: Oral Report / Presentation

Agenda Number: 22.

OPERATIONS, SAFETY, AND CUSTOMER EXPERIENCE COMMITTEE JANUARY 16, 2020

SUBJECT: P2000 LIGHT RAIL VEHICLE (LRV) POWERED AXLE ASSEMBLY OVERHAUL

ACTION: CONTRACT AWARD

RECOMMENDATION

AUTHORIZE the Chief Executive Officer to award a 60-month, Indefinite Delivery/Indefinite Quantity (IDIQ) Contract No. MA53169000 to Pamco Machine Works, the lowest responsive and responsible bidder, for the overhaul of P2000 Light Rail Vehicle (LRV) Powered Axle Assembly Overhaul. This award is a not-to-exceed amount of \$3,132,902 subject to resolution of protest(s), if any.

ISSUE

This procurement is for the acquisition of Powered Axle Assembly overhaul services as described by the Original Equipment Manufacturer (OEM) established maintenance guidelines. This project encompasses overhaul of fifty-two (52) LRVs in addition to (10) spare Powered Axle assemblies or 228 axle assemblies in total. Completion of this overhaul ensures the P2000 fleet remains in a constant State of Good Repair (SGR) while safeguarding passenger safety, vehicle performance and equipment longevity.

DISCUSSION

The P2000 Light Rail Vehicle (LRV) fleet is in its eighteenth (18) year of revenue operation with the highest mileage car at 1.75 million miles and a cumulative fleet mileage of 45 million miles. To ensure continued passenger safety and equipment reliability the Powered Axle Assembly overhaul is recommended by the OEM at a time base interval of 4 years. The Powered Axle Assembly consists of heavy-duty mechanical components including axle sets, wheels, traction gear units, brake disc, ground rings and journal bearings assemblies. Wear and tear of these component are predictable, necessitating periodic overhauls accomplished by a vendor with specialized equipment and mechanical expertise.

The P2000 Powered Axle Overhaul is in its 2nd overhaul cycle since and is (1 of 5) systems currently under a component overhaul program. This overhaul is defined by the OEM as a standard maintenance activity to be completed every 4 years. Other systems include Coupler, Friction Brake & Air Compressor, Auxiliary Inverter (completed), and GTO Driver Board Overhaul (completed).

Metro's Transit Asset Management and Operations staff conducted a condition assessment of the

P2000 fleet in the fall of 2016. The P2000 fleet's overall State of Good Repair (SGR) rating is 2.45 out of 5.0 for an overall adequate rating. This represents an asset that has reached its mid-life and has some moderately defective or deteriorated components. The condition assessment suggested that by performing the recommended OEM mid-life (Modernization) overhauls, currently accomplished under a separate project, overhauling or replacing in-kind the Propulsion equipment, Heating Ventilation & Cooling (HVAC) equipment, Traction Motors, and Auxiliary Power equipment, the vehicles would then be expected to reach the intended design life of 30-years based on statistical condition decay models.

Rail Fleet Services (RFS) Engineering developed an equipment overhaul specification for the Powered Truck Assembly overhaul based upon the OEM recommendations and with RFS maintenance experience. The contractor will perform overhaul services in accordance with a defined schedule and with Metro's technical specifications requirements.

Metro's Diversity & Economic Opportunity Department (DEOD) did not establish a goal for this procurement based on the lack of subcontractor opportunities.

DETERMINATION OF SAFETY IMPACT

Safety is of the utmost importance to Metro and, therefore, it is imperative to maintain the P2000 fleet without deferred maintenance and in a constant state of good repair. The Powered Axle Assembly overhaul will be accomplished in conjunction with the Modernization overhaul program thereby ensuring the fleet is overhauled in accordance with regulatory standards, according to the defined schedule and technical specifications requirements, and within Metro's internal standards, policies and procedures. This procurement is part of the on-going LRV preventive maintenance program.

FINANCIAL IMPACT

Funding in the amount of \$100,000 for this procurement is included in the FY20 budget under account 50316, Professional and Technical Services, Cost Center 3940, Executive Director, Rail Maintenance, Project 300055, Gold Line Operations.

Since this is a multi-year contract, the cost center Manager, Project Manager, and Sr. Executive Officer will ensure that the balance of funds are budgeted in future fiscal years.

IMPACT TO BUDGET

The current source of funds for this action are Fares, Prop A, Measure R, Measure M, State SB1, STA, Cap and Trade, and Federal formula grants. Using these funding sources will maximize allowable project funding allocations given approved provisions and guidelines.

IMPLEMENTATION OF STRATEGIC PLAN GOALS

Approval of this recommendation supports the following Metro Strategic Plan Goal 2, Deliver outstanding trip experience for all users of the transportation system.

ALTERNATIVES CONSIDERED

Deferral of this program is not recommended as the Powered Axle Assembly is an integral component of the vehicle systems that if not properly maintained could result in equipment failures, service delays, risk to passenger safety, with negative impact to vehicle available and reliability.

NEXT STEPS

Overhaul of the P2000 LRV Powered Axle Assembly overhaul will continue in accordance with Rail Fleet Services' scheduled requirements. If approved, the project is scheduled to commence in February 2020.

ATTACHMENTS

Attachment A - Procurement Summary

Attachment B - DEOD Summary

Prepared by: Bob Spadafora, Sr. Executive Officer, Rail Fleet Services
(213) 922-3144
Richard M. Lozano, Sr. Director, Rail Vehicle Maintenance,
(323) 224-4042

Reviewed by: James T. Gallagher, Chief Operations Officer, (213) 418-3108
Debra Avila, Chief Vendor/Contract Management Officer,
(213) 418-3051

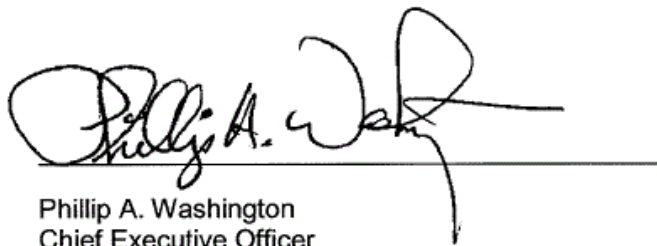

Phillip A. Washington
Chief Executive Officer

PROCUREMENT SUMMARY

P2000 Light Rail Vehicle (LRV) Powered Axle Assembly Overhaul Contract No. MA53169000

1.	Contract Number: MA53169000	
2.	Recommended Vendor: Pamco Machine Works	
3.	Type of Procurement (check one): <input type="checkbox"/> IFB <input checked="" type="checkbox"/> RFP <input type="checkbox"/> RFP-A&E <input type="checkbox"/> Non-Competitive <input type="checkbox"/> Modification <input type="checkbox"/> Task Order	
4.	Procurement Dates:	
	A. Issued: 9/05/2018	
	B. Advertised/Publicized: 9/05/2018	
	C. Pre-Bid Conference: 9/14/2018	
	D. Bids Due: 10/17/2019	
	E. Pre-Qualification Completed: 11/21/19	
	F. Conflict of Interest Form Submitted to Ethics: 01/15/2019	
	G. Protest Period End Date: 12/09/2019	
5.	Solicitations Picked Up/Downloaded: 25	Bids Received: 2
6.	Contract Administrator: Edmund Gonzales	Telephone Number: 213/418-3073
7.	Project Manager: Richard Wurtele	Telephone Number: 310/816-5504

A. Procurement Background

This Board Action is to approve Contract No. MA53169000 to procure overhaul services for the P2000 Light Rail Vehicle (LRV) Powered Assembly Axles in support of Metro's Blue and Green Lines. Board approval of contract award is subject to resolution of any properly submitted protest.

The Request for Proposal (RFP) No. MA53169 was issued in accordance with Metro's Acquisition Policy and the contract type is an Indefinite Delivery/Indefinite Quantity (ID/IQ).

Seven (7) amendments were issued during the solicitation phase of the RFP:

- Amendment No. 1, issued on October 9, 2018, extended the due date for proposals to October 29, 2018.
- Amendment No. 2, issued on October 24, 2018, extended the due date for proposals to November 13, 2018.
- Amendment No. 3, issued on November 9, 2018, provided Revision 1 to the Technical Specification and extended the due date for proposals to November 30, 2018.
- Amendment No. 4, issued on April 11, 2019, changed the contract Period of Performance; provided a revised Statement and Work, Specifications, technical documents; revised the Schedule of Quantities and Prices to reduce the quantity of AC Traction Motors to be overhauled; and extended the proposal due date April 19, 2019.
- Amendment No. 5, issued on April 18, 2019, revised the Schedule of Quantities and Prices and extended the proposal due date to April 22, 2019.
- Amendment No. 6, issued on June 21, 2019, provided a revised Statement of Work, revised Minimum Contractor Qualifications and Requirements, provided a revised

Schedule of Quantities and Prices to delete all remaining Traction Motors from the procurement, and extended the proposal due date to July 1, 2019.

- Amendment No. 7, issued on October 10, 2019, provided a revised Schedule of Quantities and Prices to delete pricing for Powered Axle spare parts and substitute pricing for Gear Unit spare parts, and extended the proposal due date to October 17, 2019.

A total of two (2) proposals were received on October 17, 2019. The proposers are listed below in alphabetical order:

1. ORX
2. Pamco Machine Works (Pamco)

Evaluation of Proposals

This procurement was conducted in accordance with and complies with Metro's Acquisition Policy for a competitive Technically Acceptable Low Price (TALP) RFP. The Proposal Evaluation Team (PET) evaluated each proposal to determine technical compliance and acceptability on a pass/fail basis against the evaluation criteria and posed questions that were answered by the proposers. Both firms, ORX and Pamco, met the RFP's technically acceptable requirements and the award recommendation was made to the lowest priced technically acceptable firm. Pamco was found to be the lowest priced proposer in full compliance with the RFP and its technical requirements.

B. Price Analysis

This procurement was a TALP. Pamco offered the lowest technically acceptable priced proposal. The recommended total price from Pamco has been determined to be fair and reasonable based upon Metro's award to the lowest price offer and adequate price competition in accordance with TALP RFP requirements. Pamco's price proposal was nine percent (9%) lower than Metro's Independent Cost Estimate (ICE).

	Contractor	Proposed Total Price	Metro ICE
1.	Pamco	\$3,132,902	\$3,446,776
2.	ORX	\$3,776,795	

C. Background on Recommended Contractor:

Pamco Machine Works., located in Rancho Cucamonga, CA, has been in business since 1967. They provide mechanical repair services for several types of rotating equipment including gearboxes and rail wheelsets. Pamco has provided similar products to other transit agencies including Miami-Dade Transit, San Francisco Bay Area Rapid Transit (BART) Maryland Transit Authority, and New Jersey Port Authority Transit. They are currently performing light rail powered axle repair services for Metro. Their performance has been satisfactory.

DEOD SUMMARY

**P2000 LIGHT RAIL VEHICLE (LRV) POWERED AXLE ASSEMBLY
OVERHAUL/MA53169000****A. Small Business Participation**

The Diversity and Economic Opportunity Department (DEOD) did not establish a Small Business Enterprise (SBE) or a Disabled Veteran Business Enterprise (DVBE) goal for this Original Equipment Manufacturer (OEM) procurement of P2000 Light Rail Vehicle (LRV) Powered Axle Assembly Overhaul services. DEOD determined there was a lack of available SBE/DVBE certified firms to perform assembly overhaul services. Pamco Machine Works proposed one non-SBE/DVBE subcontractor, the OEM of the P2000 LRV Powered Axle Assembly. Pamco Machine Works did not make an SBE/DVBE commitment.

B. Living Wage and Service Contract Worker Retention Policy Applicability

The Living Wage and Service Contract Worker Retention Policy (LW/SCWRP) is not applicable to this contract.

C. Prevailing Wage Applicability

Prevailing wage is not applicable to this contract.

D. Project Labor Agreement/Construction Careers Policy

Project Labor Agreement/Construction Careers Policy is not applicable to this Contract. Project Labor Agreement/Construction Careers Policy is applicable only to construction contracts that have a construction contract value in excess of \$2.5 million.

**Board Report**

File #: 2019-0816, **File Type:** Contract**Agenda Number:** 25.

**OPERATIONS, SAFETY, AND CUSTOMER EXPERIENCE COMMITTEE
JANUARY 16, 2020****SUBJECT: ENTERPRISE SAFETY MANAGEMENT SYSTEM****ACTION: APPROVE CONTRACT MODIFICATION****RECOMMENDATION**

AUTHORIZE the Chief Executive Officer to execute Modification No. 3 to Contract No. PS43249000 with Cority Software Inc. to add the Environmental and Ergonomics modules to the Enterprise Safety Management System (ESMS) in the amount of \$594,980, increasing the total contract value from \$1,292,926 to \$1,887,906 and extending the contract period of performance through December 31, 2020.

ISSUE

The requested modification authorizes the addition of two new modules to the ESMS system currently under development. In addition to the current modules which manage safety incidents on bus and rail, the new modules will focus on upgrading the reporting of ergonomic and environmental safety hazards, a critical piece in meeting federal health and safety regulatory reporting standards. This modification will allow for ergonomic and environmental reporting of the web and mobile application solution on the ESMS system. Additionally, the current ergonomic and environmental solution is outdated and in need of automation, which the ESMS system provides.

BACKGROUND

The Board approved a contract with Cority Software Inc., in June 2018 to implement the ESMS system. The ESMS is currently being implemented as a replacement for the Vehicle Accident and Monitoring System (VAMS) as well as the TransitSafe system which have reached obsolescence. Metro's VAMS and TransitSafe systems are the central repository for all bus and non-bus vehicle accidents, incidents, and injuries. VAMS was developed in 1984 to handle bus accidents and was expanded in 1991 to include rail accidents. To augment the limited VAMS functionality, TransitSafe software was integrated with VAMS and implemented in 2004. VAMS was used for reporting and administrative functions, and TransitSafe was used to capture accident, incident, and injury details. Over the last 25 years, VAMS and TransitSafe's business logic has been continually upgraded to meet Metro's changing business needs and regulatory requirements. Currently, the system captures Bus, Rail, and Non-revenue accident details, personal injuries, all work-related incidents, supervisory investigations, field investigations, instructor investigations, hazards, observations, efficiency testing

records, audit findings and tracking, inspection findings and tracking, corrective actions, accident review cycle, blind claims, other accident/incident related information, and regulatory reports. The VAMS/TransitSafe systems have now reached obsolescence and the vendor has discontinued support for these systems. Metro is implementing the new ESMS system to incorporate the latest technology solutions for monitoring and adapting to the evolving safety and regulatory reporting requirements. The current system does not cover incidents/accidents related to ergonomic or environmental issues.

DISCUSSION

The intent of integrating the Environmental module into the ESMS system is to automate the current paper-based environmental management process. The new Environmental module being proposed will automate processes and procedures to reduce risk and increase compliance for Metro. Metro will have the ability to handle compliance in a real-time environment with access to data, instant notifications, and tracking of corrective actions on an auditable approval system. The system will also serve as a repository to store permits, corrective action requests, inspection and compliance correspondence and other information that is pertinent to the sustainability decision-making process. Additionally, the system includes GIS mapping functionality to track locations of environmental assets and permit-ready locations throughout Metro's territory.

The Ergonomics module will provide for the management of physical access-related safety concerns for employees within Metro facilities and fleet vehicles. The new module will assist Metro in its management of these issues to enable Metro's commitment to supporting reasonable accommodations when medically and legally necessary, or when requested by employees to meet certain operational or situational conditions.

DETERMINATION OF SAFETY IMPACT

Approval of the contract modification will ensure that the agency better identifies risks, prevents injury and illness, and safeguards the health and safety of the workforce.

FINANCIAL IMPACT

The additional funding of \$594,980 will be added to the FY20 budget under cost center 9210, for Contract No. PS43249000, increasing the total contract value to \$1,887,906. The recommended contract modification is within the Board approved capital Life-of-Project budget for CP 207153. Since this is a multi-year project, the project manager and the Chief Information and Technology Officer will be responsible for budgeting the project funds.

Impact to Budget

The funding for this action will be a combination of local, state and federal operating funds.

IMPLEMENTATION OF STRATEGIC PLAN GOALS

Improved safety assessment and reporting supports Metro Vision 2028, Strategic Goal 5: "Provide

responsive, accountable, and trustworthy governance within the Metro organization,” and specifically fulfills Initiative 5.6: “Metro will foster and maintain a strong safety culture.”

ALTERNATIVES CONSIDERED

The Board may choose not to approve the contract modification. This option is not recommended as Metro’s existing systems are obsolete and do not meet the needs of ergonomic and environmental reporting. By approving the staff recommendation, Metro can take advantage of the technology solutions currently available to meet the needs of the agency.

NEXT STEPS

Upon approval by the Board, staff will execute Modification No. 3 to Contract No. PS43249000 and will re-baseline the project management plan and schedule to implement the new Environmental and Ergonomics modules.

ATTACHMENTS

- Attachment A - Procurement Summary
- Attachment B - Contract Modification/Change Order Log
- Attachment C - DEOD Summary

Prepared by: Al Martinez, Senior Director, IT, (213) 922-2956
Patrick Astredo, Deputy Executive Officer, IT, (213) 922-4290

Reviewed by: Kenneth L. Hernandez, Chief Risk, Safety and Asset Management Officer, (213) 922-2990
Bryan Sastokas, Chief Information Technology Officer, (213) 922-5510
Debra Avila, Chief Vendor/Contract Management Officer, (213) 418-3051

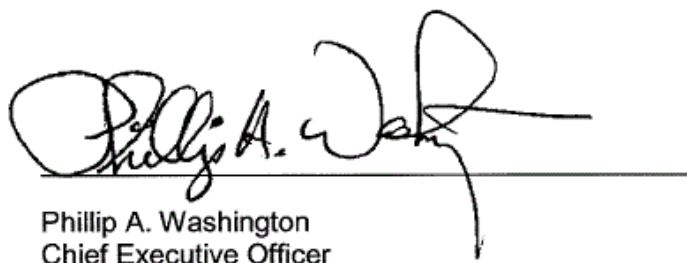

Phillip A. Washington
Chief Executive Officer

PROCUREMENT SUMMARY

ENTERPRISE SAFETY MANAGEMENT SYSTEM/PS43249000

1.	Contract Number: PS43249000		
2.	Contractor: Cority Software, Inc.		
3.	Mod. Work Description: Add Environmental and Ergonomics Modules		
4.	Contract Work Description: Enterprise Safety Management System		
5.	The following data is current as of: 11/20/19		
6.	Contract Completion Status		Financial Status
	Contract Awarded:	6/28/2018	Contract Award Amount: \$1,292,926
	Notice to Proceed (NTP):	7/27/2018	Total of Modifications Approved: \$0
	Original Complete Date:	7/25/2019	Pending Modifications (including this action): \$594,980
	Current Est. Complete Date:	12/31/2020	Current Contract Value (with this action): \$1,887,906
7.	Contract Administrator: Ana Rodriguez		Telephone Number: (213) 922-1076
8.	Project Manager: Al Martinez		Telephone Number: (213) 922-2956

A. Procurement Background

This Board Action is to approve Contract Modification No. 3 issued to add Environmental and Ergonomics modules to the Enterprise Safety Management System.

This Contract Modification will be processed in accordance with Metro's Acquisition Policy and the contract type is a firm fixed price.

On June 28, 2018, Contract No. PS43249000 for the Enterprise Safety Management System was awarded to Cority Software, Inc. in the firm fixed price contract amount of \$1,292,926.

Refer to Attachment B – Contract Modification/Change Order Log for modifications issued to date.

B. Cost/Price Analysis

The recommended price has been determined to be fair and reasonable based upon an independent cost estimate, cost analysis, fact finding, and negotiations.

Proposal Amount	Metro ICE	Negotiated Amount
\$866,717	\$598,675	\$594,980

CONTRACT MODIFICATION/CHANGE ORDER LOG

ENTERPRISE SAFETY MANAGEMENT SYSTEM/PS43249000

Mod. No.	Description	Status (approved or pending)	Date	\$ Amount
1	No cost modification to add a Subcontractor	Approved	4/10/19	\$0
2	No cost modification for period of performance extension	Pending	11/20/19	\$0
3	Environmental and Ergonomics Modules, and period of performance extension	Pending	Pending	\$594,980
	Modification Total:			\$594,980
	Original Contract:			\$1,292,926
	Total:			\$1,887,906

DEOD SUMMARY

ENTERPRISE SAFETY MANAGEMENT SYSTEM / PS43249000

A. Small Business Participation

The Diversity and Economic Opportunity Department (DEOD) did not establish a Disadvantaged Business Enterprise (DBE) goal for this project due to lack of subcontracting opportunities. As confirmed by the Project Manager, the Enterprise Safety Management System (ESMS) is proprietary software and the required hardware is being procured, installed, and maintained by Metro personnel.

B. Living Wage and Service Contract Worker Retention Policy Applicability

The Living Wage and Service Contract Worker Retention Policy is not applicable to this contract.

C. Prevailing Wage Applicability

Prevailing wage is not applicable to this contract.

D. Project Labor Agreement/Construction Careers Policy

Project Labor Agreement/Construction Careers Policy is not applicable to this contract.



Board Report

File #: 2019-0658, File Type: Plan

Agenda Number: 26.

OPERATIONS, SAFETY, AND CUSTOMER EXPERIENCE COMMITTEE JANUARY 16, 2020

SUBJECT: I-10 EXPRESSLANES BUSWAY HOV5+ PILOT IMPLEMENTATION PLAN

ACTION: APPROVE RECOMMENDATIONS

RECOMMENDATION

CONSIDER:

- A. APPROVING I-10 ExpressLanes Busway HOV5+ Pilot Implementation Plan; and
- B. AUTHORIZING implementation of the I-10 ExpressLanes Busway HOV5+ Pilot.

ISSUE

In April 2018, the Metro Board of Directors adopted a motion requesting that Metro staff work with Caltrans and other stakeholders to develop a pilot program (Pilot) exclusively for the I-10 ExpressLanes increasing the required occupancy for toll free travel from HOV2/HOV3+ to buses and vanpools, as a means of preserving the ExpressLanes as a faster and more reliable travel option for ExpressLanes corridor travelers and transit users.. The stated objectives of the Pilot are to:

- Keep transit moving in the ExpressLanes.
- Move people more efficiently in the ExpressLanes.
- Reduce occupancy misrepresentation by ExpressLanes users.

In January 2019, Metro staff reported on the potential effects of the Pilot, key decision points and milestones for implementation including feedback received from corridor users on the potential impacts of the Pilot with emphasis on low-income commuters. At that time, the Metro Board of Directors authorized Metro staff to develop a more detailed implementation plan for the Pilot. This report is in response to the direction provided in January.

Staff is recommending a phased approach with Phase 1 providing free passage to transit and registered vanpools and Phase 2 adding HOV5+ vanpools to those traveling free of charge on the ExpressLanes. This approach will enable an expedited deployment of the Pilot and evaluation of two different policies which will better inform the final decision regarding the most effective policy to implement upon conclusion of the Pilot.

DISCUSSION

The I-10 ExpressLanes Busway HOV5+ Pilot Implementation Plan describes all major activities required to successfully deploy the Pilot. It has been informed by an extensive literature review of best practices, consultation with industry experts, and original research including 15 peer/partner agency interviews, 2,400 stakeholder surveys, nine focus groups, and detailed data analysis. The Implementation Plan discusses the following major activities associated with the pilot development and implementation:

- Phased Approach to Implementation
- Public education and marketing campaign efforts
- Mitigation strategies and incentives
- Roadside signage considerations
- Development of a robust solution for occupancy declaration and verification
- Before-and-after data collection and evaluation
- Concurrence from Caltrans and FHWA

The Implementation Plan concludes with a review of expected costs for implementation, a discussion of recommended deployment schedule for Phases 1 and 2, and a description of known risks and potential associated protections against them. Summaries of each category of activities in the Implementation Plan are provided in the following sections, with additional detail available in the full plan document (see Attachment A).

Public education and marketing campaign efforts

The Implementation Plan includes a multi-faceted public education and marketing plan covering all impacted audiences, with a focus on historically underserved and low-income populations. Outreach for the Pilot will begin three to six months in advance of the anticipated go-live date for each phase and will include:

- Community events and meetings with community groups and civic leaders.
- Presentations to partner agencies and key stakeholder groups.
- Targeted outreach to existing customers by e-mail and postal mail.
- Broader public outreach to corridor users and other stakeholders (e.g., vanpools, employers, commuters) using a range of media including radio, digital display boards, social media, newspapers, and Metro channels (e.g., onboard vehicle advertising, 511, Metro web site development and updating).

Mitigation Strategies and Incentives

Several complementary support strategies and programs are included in the Implementation Plan to promote a smooth and successful pilot deployment. These include mitigation strategies to address the potential impacts of the Pilot to existing HOV2-HOV4 corridor users that could lose toll-free access to the I-10 ExpressLanes, and incentive strategies to further encourage and facilitate shifts to more efficient travel modes including transit and vanpools. All strategies were selected based on a detailed screening across several metrics including alignment with Pilot objectives and goals, feasibility of deployment within the Pilot timeframe, and ability to address the specific program impacts and mode shift barriers identified by current users of the corridor through surveys and focus groups. The mitigation strategies and incentives that will be deployed on the I-10 ExpressLanes corridor as part of the Pilot are:

- Providing a two-month grace period for HOV2 and HOV3+ customers at the start of the

- deployment period in which they continue to receive toll-free travel.
- Continuing existing Carpool Loyalty program for HOV2 and HOV3+ customers.
 - Continuing investment in transit services.
 - Expanding the existing Transit Rewards program to increase the frequency of rewards for transit users on the I-10 corridor.
 - Expanding the Carpool Loyalty program, as part of Phase 2, to include dedicated rewards for a new class of HOV5+ customers beyond those offered to HOV2/HOV3+ classes.
 - Promoting the existing Universal College Student Transit Pass (U-Pass) program for access to reduced transit fares for students using the corridor.

Roadside Signage Considerations

Aspects of the Pilot that affect roadside signage on I-10 include the toll-free travel for buses and registered vanpools (Phase 1) and the new definition of HOVs and the new declaration method (Phase 2). To address the new definition of HOVs, the existing signage that defines the occupancy requirements by time of day is anticipated to be replaced with new signage indicating, "Buses and registered Vanpools No Toll" (Phase 1), and "HOV5+ & registered Vanpools must register for No Toll" (Phase 2). Additionally, for Phase 2, a supplemental sign stipulating "HOV5+ is 5 or more persons per vehicle" will be placed along the corridor intermittently. To address toll-free travel during Phase 1 and Phase 2, the existing optional/discretionary signage that reminds drivers that "All HOV must have FasTrak" would be replaced with new signage reading, "Vanpools call 511 for tolling info," or "HOV 5+ call 511 for discount info" respectively. Upon calling 511, and depending on the current phase of Pilot operation, drivers would be informed about how to travel toll free on the I-10 ExpressLanes and/or about the new Pilot Mobile App and how to use it to receive toll-free trips when traveling with 5 or more occupants. The pricing signs along the corridor would also be updated to remove the line, "HOV2+ \$0 w/Flex" or "HOV3+ \$0 w/Flex." The final signs to be deployed require concurrence from Caltrans and FHWA.

Development of a Robust Solution for Occupancy Declaration and Verification

A core component of the Pilot is the development and deployment of a robust method for declaring and verifying vehicle occupancies for toll-free trips (i.e., the Pilot Mobile App). For this purpose, Metro will procure the services of a mobile app developer to provide a reliable, fast, and easy-to-use smartphone-based automated vehicle occupancy declaration and verification solution, subject to accuracy requirements. A secondary alternative mobile phone method for declaration and verification will also be available for customers that do not have smartphones or for instances where the primary system is unavailable. At no time would vehicle occupants be required to interact with the Pilot Mobile App while driving. Because of the pioneering nature of this app-based approach to vehicle occupancy verification, there is a degree of schedule uncertainty and potential liability exposure associated with this aspect of the Pilot. The contract will include provisions to protect against, but not fully eliminate, these risks.

Before-and-After Data Collection and Evaluation

The primary performance metrics used in the evaluation of the I-10 HOV5+ Pilot were selected based on their alignment with the Pilot's stated objectives from the original April 2018 Board Motion. In collaboration with FHWA, and Caltrans, the following performance criteria were selected for post-Pilot evaluation:

- Travel time and travel time reliability (ExpressLanes and general-purpose lanes)

- Maintenance of 45 mph speeds on the ExpressLanes/reduction in HOV only mode.
- Transit ridership
- Transit running time
- Person throughput (ExpressLanes and general-purpose lanes)

Concurrence from Caltrans and FHWA

Concurrence from Caltrans and FHWA is required to revise the definition of HOVs on this corridor as part of the Pilot. Caltrans District 7 formally indicated its support in a letter dated September 12, 2018. On November 8, 2018, the FHWA California Division responded with a similar letter of support. Metro staff has been coordinating with representatives from both agencies throughout the development of the Implementation Plan to ensure that it remains consistent with their expectations. Both agencies are reviewing the final draft of the Implementation Plan at this time, and their concurrence is anticipated after the final review cycle.

Cost Estimate

The cost estimate for all activities associated with performing the pilot implementation plan is \$7.7 million. The major cost components are estimated as follows:

- Public education and marketing campaign: \$1.9 million
- Mitigation strategies and incentives: \$2.5 million
- Operational Elements (i.e. design, signage, CSC/BOS, mobile app) and integration: \$2.1 million
- Before-and-after data collection and Management: \$1.2 million

Schedule

Staff recommends two phases for the I-10 Pilot, with each phase containing a 12-month full deployment period, a two-month initial grace period, and a five-month post-deployment evaluation period. Additional detail about the activities preceding, within, and following the two phases are provided in the sections below. The decision to implement Phase 2 will be dependent on the performance evaluation data from Phase 1, as well as the readiness of the declaration and verification mobile app. Any delay in availability of the mobile app will delay the start of Phase 2.

Phase 1 of the Pilot is scheduled to begin October 2020 and continue for 23 months through August 2022 and is inclusive of the following:

- Two-month “grace period” which gives commuters time to acclimate to the new occupancy requirements for toll-free travel, including formation of vanpools or switching to transit,
- Twelve months of full Pilot operations,
- Five months to evaluate Phase 1 results, which will inform the decision to move forward to Phase 2 and secure Board concurrence; and
- Four months for outreach and any other necessary preparations prior to the beginning of Phase 2 operations.

During the evaluation, Metro staff will review the effectiveness of the Pilot and, based on the before and after analysis and other criteria, make a recommendation to the Metro Board. Metro anticipates a Board decision by May 2022. The Board decision could range from rolling back to pre-Pilot

implementation operation, transitioning Phase 1 to permanent operation, transitioning Phase 1 to Phase 2 operations, or some other operating scenario. Following the Board decision, Metro staff will prepare the appropriate action plan and timetable for remaining Pilot activities.

Should the Board direct staff to move forward with Phase 2 of the Pilot, Phase 2 implementation could begin by September 1, 2022 and continue for 19 months through March 2024. As this Pilot features components that are industry innovations that have not been attempted before, there is a degree of schedule uncertainty associated with achieving each of these four stages within the estimated timeframes above. The above schedule should be considered an approximate forecast only. The 19 months include:

- Two-month “grace period” which gives commuters time to acclimate to the new occupancy requirements for toll-free travel,
- Twelve months of full Pilot operations, and
- Five months to evaluate Phase 2 and to compare the results from both phases which will culminate in a Metro Board decision regarding the status of Pilot operations moving forward.

It is anticipated that following the conclusion of Phase 2 operations (November 30, 2023), staff will review the effectiveness of the Pilot and, based on the before and after analysis and other criteria, make a recommendation to the Metro Board. Metro anticipates a Board decision by April 2024, which could range from 1) the continuance of Phase 2 operations (or some form thereof), 2) reversion back to Phase 1, or 3) roll back to pre-Pilot operations. Based on the analysis and staff recommendation, the Metro Board will decide how to move forward. If the Board decides to transition the Pilot to permanent operations, Metro staff will prepare and implement a Transition to Permanent (TPO) action plan. It is anticipated Phase 2 operations will continue during the evaluation and Metro Board decision periods.

IMPLEMENTATION OF STRATEGIC PLAN GOALS

The FY18 I-10 ExpressLanes Pilot Program aligns with Strategic Goal 1: Provide high quality mobility options that enable people to spend less time traveling. ExpressLanes provides drivers with the option of a more reliable trip while improving the overall operational efficiency of the freeway network.

FINANCIAL IMPACT

Funds in the amount of \$1.9 million to initiate implementation of the Pilot are available in the FY20 budget in cost center 2220. Because this is a multi-year program, the cost center manager and the Executive Officer, Congestion Reduction programs, will be responsible for budgeting for future years.

Impact to Budget

The funding for this action will come from toll revenues generated from the Metro I-10 ExpressLanes operations. No other funds were considered for this activity.

ALTERNATIVES CONSIDERED

The Board may elect not to implement the Pilot. This alternative is not recommended since, based on current analysis, the Pilot can increase overall person throughput, assure travel time reliability for transit vehicles, and address current enforcement challenges related to scofflaws, revenue leakage and HOV-only restrictions.

NEXT STEPS

Upon Board approval, staff will perform all tasks and activities discussed in the Implementation in pursuit of the I-10 ExpressLanes Busway HOV5+ Pilot.

ATTACHMENTS

Attachment A: April 26, 2018 Board Motion 43

Attachment B: Draft I-10 ExpressLanes/Busway Pilot Implementation Plan - Executive Summary

Attachment C: Draft I-10 ExpressLanes/Busway Pilot Implementation Plan

Prepared by: Alice Tolar, Sr. Manager, Transportation Planning, Congestion Reduction,
213.418.3334

Robert Campbell, Manager, Transportation Planning, Congestion Reduction,
213.418.3170

Mark Linsenmayer, Deputy Executive Officer, Congestion Reduction, 213.922.5569

Reviewed by: Shahrzad Amiri, Executive Officer, Congestion Reduction, 213.922.3061

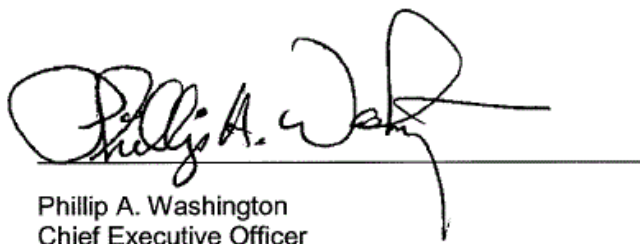

Phillip A. Washington
Chief Executive Officer

**Board Report**

File #: 2018-0195, **File Type:** Motion / Motion Response**Agenda Number:** 43.

**REGULAR BOARD MEETING
APRIL 26, 2018****Motion by:****Director Fasana****as amended by Solis****I-10 ExpressLane/Busway Pilot**

The I-10 El Monte Busway opened in 1973 as an exclusive busway with stations at El Monte, California State University at Los Angeles, and Los Angeles County USC Medical Center. The El Monte Bus Station, rebuilt and reopened in 2012, is the busiest bus terminal west of Chicago.

Construction of the busway resulted in substantial increases in bus service along the corridor. According to a study by FHWA conducted in 2002, "Executive Report Effects of Changing HOV Lane Occupancy Requirements: El Monte Busway Case Study", from 1973 to 1976, the number of buses using the lane in the morning peak-hour, peak-direction of travel increased from 21 to 64, with a corresponding increase in passengers from 766 to 3,044. Daily bus ridership levels increased from 1,000 to 14,500 passengers during the same period.

Three-person carpools were allowed to use the Busway for three months in 1974 during a strike by bus operators. The Busway was opened to 3+ carpools in 1976. At the time of conversion to an ExpressLane in 2013, the Busway operated at HOV 3+ during peak hours and HOV 2+ off-peak.

The I-10 Busway / HOV lane is being extended by Caltrans and Metro to the Los Angeles County Line, with an extension to Baldwin Park already open. San Bernardino County is beginning construction this year on an I-10 ExpressLane that would meet up with the Metro / Caltrans lane at the County line and extend to I-15 in 2022, and Redlands in 2026.

The Express Lane allows low occupancy vehicles to use the lanes with payment of a fee, which varies dynamically with traffic levels. To remain consistent with prior HOV 2+ and 3+ requirements, Metro developed a switchable Fastrak transponder for carpools. As ExpressLane acceptance among customers has grown, the busway has grown more congested and has degraded bus service in the corridor. As demand and price have increased, transponders are being switched to HOV 2+ or 3+ to avoid tolls.

The switchable transponder requires CHP to manually observe vehicles to determine if the number of

occupants is consistent with the setting on the transponder. Due to right of way constraints, enforcement of ExpressLane requirements is difficult on I-10, as limited room is available to pull-over and issue citations. CHP enforcement slows traffic in the ExpressLane.

Physical constraints within the right-of-way footprint also limit the ability to place thermal readers that may be able to detect vehicle occupants in the ExpressLane.

One alternative to CHP enforcement is to move to an automated approach where all cars are charged without regard to the number of occupants, through a "Pay-as-You-Use" model.

The Foothill Gold Line and Metrolink also provide east/west service through the San Gabriel Valley. The Gold Line, which will extend east to Montclair, currently is operating at capacity in some locations during peak hours according to the "Metro Rail Capacity Study" that is being presented to the System Safety, Security and Operations Committee in April 2018.

As Metro prepares to expand its ExpressLane network, piloting a new operating approach on I-10 will provide valuable insight on how best to maximize mobility on ExpressLanes.

Therefore, to keep buses moving and enable movement of more people efficiently within the I-10 ExpressLane,

**SUBJECT: MOTION BY FASANA AS AMENDED BY SOLIS
I-10 EXPRESSLANE/BUSWAY PILOT**

APPROVE Motion by Fasana that:

- A. Metro staff work with Caltrans and other stakeholders to develop, within existing federal and state guidelines, a pilot exclusively for the I-10 ExpressLane / Busway that would define carpools as registered vanpools with all other vehicles (other than passenger buses) subject to fees through a "Pay-as-You-Use" model. The Zero Emission Vehicles using the corridor would be eligible for discounts in effect at the time the pilot commences; and
- B. Report back to the Metro Board within 180 days on potential effects, key decision points and milestones necessary to implement this pilot including community outreach with feedback and surveys as well as service analysis on impacts and exemptions for low income commuters. The proposed pilot program to be consulted with SCAQMD in relation to Air Quality Management Plan and its impact to sticker program for Electric Vehicle.



Metro

ATTCHMENT B

I-10 ExpressLanes/Busway

PILOT IMPLEMENTATION PLAN

A DEGRADATION MITIGATION STRATEGY



December 2019

Prepared by:

HNTB

Executive Summary

Introduction

Due to factors such as increased demand, capacity constraints west of the I-710 freeway, operational challenges approaching the I-10/I-605 interchange, and occupancy misdeclaration, degradation on the I-10 ExpressLanes has been increasing. A High Occupancy Vehicle (HOV) lane or ExpressLane is considered degraded if average traffic speeds during the morning or evening weekday peak commute period fall below 45 miles per hour for more than 10 percent of the time over a consecutive 180-day period. Currently, the facility requires three or more persons for toll free travel during the AM and PM peak periods (HOV 3+) and two or more persons for toll free travel (HOV 2+) at all other times.

In response, the Los Angeles County Metropolitan Transportation Authority's (Metro) Board of Directors (Board) put forth a motion in April 2018 that proposed developing a new operating approach on I-10 by increasing the occupancy requirements in the ExpressLanes. The Board motion included the following:

- Metro staff will work with Caltrans and other stakeholders to develop, within existing federal and state guidelines, a pilot exclusively for the I-10 ExpressLanes/Busway that would define carpools as registered vanpools with all other vehicles (other than passenger buses) subject to fees through a "Pay As You Go" model. The zero emission vehicles using the corridor would be eligible for discounts in effect at the time the pilot commences; and
- Metro staff will report back to the Metro Board within 180 days on potential effects, key decision points, and milestones necessary to implement the pilot, including community outreach with feedback and surveys and service analysis on impacts and exemptions for low-income commuters.

In January 2019, the Ad Hoc Congestion, Highway, and Roads Committee issued a motion in response to the April 2018 motion referenced above. This motion requested that Metro Staff report on:

1. Potential effects of implementing the Pilot;
2. Key decision points and milestones for implementation; and
3. Solicitation of feedback and evaluation of potential impacts associated with this Pilot with a focus on low-income commuters.

The Board adopted this motion authorizing the development of this Pilot Implementation Plan (PIP) to increase the I-10 ExpressLanes minimum occupancy requirement. Metro and Caltrans staff have also been coordinating with the Federal Highway Administration (FHWA) and FHWA has provided authorization to Caltrans and Metro to revise the definition of high-occupancy vehicles (HOV) in the I-10 ExpressLanes.

The PIP proposes a two phased approach to increasing occupancy on the I-10 – first to offer toll-free travel to transit vehicles only (defined as registered vanpools and transit) and then to vehicles with five or more occupants (HOV 5+). To accomplish this task, the PIP outlines the technical and operational requirements, communication and outreach plan, incentivization/mitigation strategies, budget, and schedule for planning and implementation.

Project Area

The project limits are identical to the existing Metro I-10 ExpressLanes between Alameda Street in the west and the I-605 freeway in the east.

I-10 ExpressLanes Project Area Map

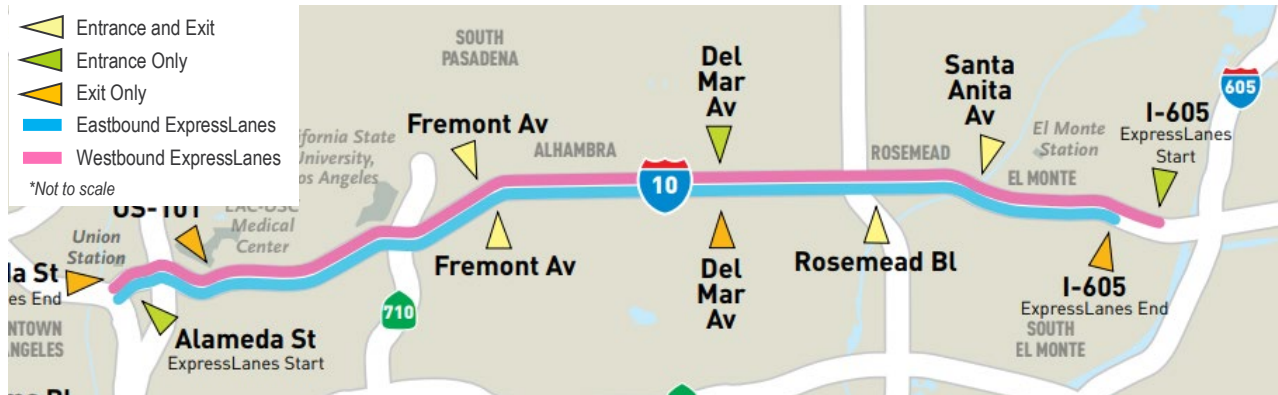

Source: LA Metro ExpressLanes website (http://media.metro.net/projects_studies/expresslanes/images/ExpressLanes_Map_Toll_Entry.pdf)

Methodology and Findings

The PIP Development Process graphic below shows the sequence of activities that were used to develop the PIP. The activities were broken down into three phases – Research, Develop, and Implement. The Research phase focused on listening and gathering information to identify opportunities and potential concerns on the transit only and HOV5+ concepts and potential Pilot. The Develop phase includes preparation of mitigation/incentivization strategies, a comprehensive outreach/education plan, and operational considerations. The implement phase will take the plans prepared in the develop phase and put them into operation. All phases will require ongoing stakeholder collaboration/communication and program management coordination, progress reporting, and oversight. The following sections summarize the process, findings, and recommendations by phase and topic.



Research

Peer Agencies Interviews

Metro's research from speaking with peer toll agencies indicated that changing existing HOV occupancy policies is a challenging task when stricter policies are proposed. When comparing interview responses, numerous commonalities emerged as essential to a successful transition, including:

- Obtaining political support; it is key to successful implementation because elected officials and key communicators can help explain, answer questions, and communicate to the public which will help extend the reach of the outreach/marketing campaign.
- Conducting extensive public outreach; develop a robust public awareness/education campaign; and thoroughly educate the public on the new requirements prior to implementation.
- Implementing mitigation strategies to help make the transition to and implementation of new requirements as easy as possible, and offer incentives to ExpressLanes users to form vanpools/vehicle pools, increase transit usage, etc.
- Providing viable transit service options.

More from the interviews with peer agencies can be found in Section 4.

Partner Transit Agencies Interviews

Each partner transit agency interviewed brought a unique perspective regarding how the potential HOV5+ occupancy requirement may affect their service and operations. More detail on the interviews can be found in Section 5. Increasing speeds and decreasing travel times and operating costs were important benefits. However, if the HOV5+ requirement reduces congestion in the ExpressLanes, buses may travel faster than the GP lanes which may entice people to ride transit rather than drive. If the Pilot is implemented, it may have financial ramifications due to agencies needing to purchase more buses and hire additional operators and staff, if there is a significant increase in transit ridership.

Key Stakeholders Interviews

Most of the stakeholders from Caltrans and FHWA feel the ExpressLanes system is effective in reducing overall congestion and improving travel times on I-10. They acknowledged the ExpressLanes are more efficient than GP lanes, but they were concerned with the potential impacts to the GP lanes once this change in occupancy requirement goes into effect. They are concerned it will increase degradation and, in some cases, divert traffic onto local streets to avoid congestion on I-10. The ExpressLanes are susceptible to congestion due to enforcement challenges, especially during peak periods. Stakeholders suggested several potential mitigation strategies to address these concerns, which can be read in Section 5. Metro considered these suggestions and incorporated them into the PIP where feasible.

Preliminary Outreach

To inform development of the PIP and the related outreach and education plan, preliminary outreach activities, including focus groups and electronic/field surveying, were conducted. A detailed description of preliminary outreach activities and findings is included in Section 6.

Focus groups were held with voluntary community participants who commute as solo drivers, vehicle/van pools, or use transit on the I-10 corridor. In addition, Metro conducted field and electronic surveys and received approximately 2,400 survey responses. Focus group and survey findings and recommendations included:

- Existing carpoolers are more likely to seek out a 5+ vehicle pool.
- Financial incentives are the most attractive.
- Simple, straightforward, and transparent communication about the Pilot is desired.

- Communication through radio and newspaper ads, billboards, highway messaging signs, email, text, direct mail, and public outreach materials and events is preferred.
- More effective ExpressLanes enforcement is needed.

Based on these findings, a Comprehensive Outreach and Education Plan (Section 8) was developed. It includes a strategic messaging campaign to help build awareness and consensus and to consistently message the need and benefit of transit only and HOV5+ prior to implementation.

Develop

Based on what was learned in the investigation phase (RESEARCH), Metro considered several activities to include as components of the PIP during its development. These options were evaluated against the Pilot's goals and objectives while considering what would potentially be the most impactful and implemented in a short timeframe. That analysis resulted in the identification of specific activities that formed the PIP (DEVELOP). These are recommended for implementation as part of the PIP (IMPLEMENT).

Phased Approach

Increasing occupancy requirements aligns with the original intent of the El Monte Busway, and it will help mitigate degraded conditions caused by overutilization of the existing ExpressLanes, particularly where capacity is more constrained (e.g., I-10 ExpressLanes single-lane segments).

The Metro Board's April 2018 motion was to implement a Pilot that increases toll-free occupancy requirements from HOV2+/HOV3+ to transit (buses and vanpools only) to preserve the ExpressLanes as a fast, reliable travel option. After the motion was approved, Metro prepared the *I-10 ExpressLanes/Busway Preliminary Assessment* (October 2018), which provided an alternative option of allowing HOV5+ vehicles to travel toll free. As a result, the PIP proposes a two phased approach to increasing occupancy as follows:

- **Phase 1:** Transit only (buses and registered vanpools) travels toll free in the ExpressLanes; all others pay the full toll. (add how you would register a vanpool)
- **Phase 2:** Addition of HOV5+ vehicles travel toll free in the ExpressLanes; introduction of an occupancy declaration/verification mobile application (app).

Under the Pilot, Metro would revise the current definition of the HOV policy of HOV3+ (three-or-more-person vehicle pool) during peak and HOV2+ (two-person vehicle pool) during off-peak periods to transit only (buses and registered vanpools) in Phase 1 and then add HOV5+ (five-person vehicle pool) in Phase 2 for toll-free travel in the ExpressLanes.

In Phase 2, HOV5+ vehicles wishing to take advantage of toll-free travel will need a valid FasTrak® account and transponder or sticker tag on a vehicle's windshield, and they would have to declare a vehicle occupancy of at least five people using a mobile application (app).

PIP Support Strategies

The PIP also identifies potential mitigation and incentivization support strategies. Their purpose is to mitigate the Pilot's impacts on current HOV2+/3+ ExpressLanes users who will have to pay a toll under the Pilot and to encourage transit use and the formation of vanpools and 5+ vehicle pools. Certain existing Metro programs will also be featured as support strategies. The recommended mitigation and incentivization strategies are consistent with input received from focus groups and

field/online surveys conducted as part of the preliminary outreach efforts which informed development of the PIP.

Mitigation Strategies

The purpose of mitigation strategies is to offset the real or perceived impacts of changing the toll-free occupancy requirement from 2+/3+ to transit only and then HOV5+. The top mitigation strategies recommended for the Pilot include:

- Provide an introductory grace period of two months for 2+/3+ carpools (depending on peak period) where they can travel for free before the full implementation of each phase.
- Expand the existing 2+/3+ Carpool Loyalty Program.
- Expand the existing Transit Rewards Program.

Incentivization Strategies

Incentivization strategies are designed to encourage transit use and the formation and use of vanpools and 5+ vehicle pools beyond the financial incentive of toll-free travel. The top incentive strategies recommended for the Pilot are:

- Develop Vanpool and HOV5+ Vehicle Pool Loyalty Toll Credit Drawing Programs (similar to the current HOV2+/3+ program).
- Establish a Vehicle Pool Rewards program where the HOV5+ vehicle pool driver would receive a toll credit after 16 one-way trips during peak periods.

Existing and Potential Programs

The Pilot will benefit from the continuance of Metro's current Low-Income Assistance Plan and Guaranteed Ride Home Program. These programs will be continued, and ongoing outreach and education will be provided as part of the PIP. Metro will also continue current internal/external programs and relationships during the Pilot by collaborating with Metro Transit and other transit partners, 511, and third-party traffic information providers (e.g. Waze) or similar programs.

Additionally, an opportunity exists to further develop the concept of a Transit Re-Investment Program which would use excess toll revenues to enhance existing transit operations. This could encourage commuters to use transit over vehicles and increase passenger throughput, a goal of Metro's Congestion Reduction Program and this Pilot. As part of the Pilot's next steps, staff will collaborate with I-10 ExpressLanes transit operators (Metro and Foothill Transit) and continue to develop guidelines/criteria for participation in this potential program.

Disadvantaged Community and Equity Considerations

In all PIP and Pilot activities, Metro will focus on reaching and meeting the needs of disadvantaged communities and addressing equity concerns and opportunities. For the PIP, this primarily includes outreach activities and the continuance of the Low-Income Assistance Plan. Should the Pilot be successful and become permanent or extended to other Metro ExpressLanes facilities, there may be opportunities to further enhance these programs based on lessons learned during the Pilot.

Comprehensive Outreach and Education Campaign and Support Strategies Implementation

Section 8 discusses Metro's plan to implement a comprehensive public outreach/education campaign to support the Pilot. The program was developed based on input from focus groups,

surveys, stakeholders, and peer agencies and in close coordination with the Metro Marketing and Community Relations teams. The program's purpose is to 1) ensure I-10 corridor travelers are informed about the Pilot and the changes that will come with each phase; 2) mitigate impacts from the Pilot on current ExpressLanes users; and 3) encourage transit use and the formation of vanpools and HOV5+ vehicle pools as an alternative to driving alone or in smaller carpools. It will focus efforts on historically underserved and low-income populations and ensure all the appropriate audiences are reached.

Comprehensive outreach/education activities include:

- Communicating directly with Metro ExpressLanes FasTrak® customers.
- Engaging existing partnerships with key stakeholder groups within the San Gabriel Valley, sharing information with new stakeholders, and distributing collateral materials online, in-person, and by mail.
- Participating in targeted community events and meetings with community leaders in known I-10 commute sheds, with a focus on low-income and disadvantaged communities.
- Advertising on radio, digital display boards, and local newspapers, and Metro-owned media, including onboard rail/transit/bus advertising, 511, Metro and partner websites, and Metro Source articles.
- Leveraging Facebook, Instagram, and Twitter, which will act as tools to monitor and respond to public reactions to the Pilot.
- Utilizing free mediums available (social, digital, and press release [PR], editorial board, etc.) to maximize the number of impressions¹ and the budget.
- Conducting focus groups and electronic surveys to gather feedback.

Metro will also perform further education and outreach activities to support continuance of the Pilot or to revert to pre-Pilot operations depending on the Board's direction.

Operational Considerations

There are several operational considerations to be addressed for successful implementation of the Pilot. The Implementation Roadmap includes the following activities:

- Implement required signage changes to reflect the change to buses/registered vanpools only and then HOV5+ for toll-free travel in the I-10 ExpressLanes (Section 9 and Appendix A).
- Develop pre- and post-Pilot data needs and establish a baseline data and collection plan to assess impacts from each phase (Section 10).
- Procure and implement the mobile app for occupancy declaration prior to beginning Phase 2 (Section 9.4).
- Assess and implement needed modifications to BOS and customer service center (CSC) technology to support the Pilot.
- Train CHP enforcement officers, ExpressLanes customer service representatives, and other Metro staff for the Pilot.

¹ Impressions are the number of times an advertisement is viewed/heard by the public.

These activities will need to be completed before Go Live for Phases 1 and 2. Some of these activities are already underway. For example, Metro continues to meet with Caltrans and FHWA regarding signage changes and to identify data needs to evaluate the Phase 1 implementation. Also, preparations are underway for the mobile app procurement and to address potential customer service technology needs.

Implement

Program/Project Management

The PIP and the Pilot will be implemented and managed by Metro's Congestion Reduction Department. Program/ Project Management will be ongoing throughout the develop and implement phases. Specific program management tasks will include progress reporting, defining the decision-making structure, establishing a risk register/mitigation strategy (Appendix C), budget management, regularly reviewing the schedule and identifying critical path tasks, maintaining open issues lists, and conducting regular project team meetings.

Stakeholder Collaboration

Beginning shortly after Board approval and leading up to and during the Pilot, Metro will continue ongoing stakeholder collaboration with peer transit agencies, Caltrans, FHWA, CHP, and other stakeholders that provided input for the PIP, including KPIs to measure Pilot success. Collaboration activities will include meetings with stakeholders to review the PIP, establishing regular meetings leading up to and during the Pilot to share information, evaluating how the Pilot is progressing, and making course corrections as needed. PIP and Pilot Budget

As indicated below, the budget for the Pilot is expected to be around \$7.9 million. A description of the cost estimate methodology is provided in Section 11.

TASK	COST
Outreach/Education/Marketing	\$1,895,215
Mitigations/Incentives	\$2,450,910
Operational Elements (i.e., design, signage changes, CSC/BOS, mobile app)	\$2,109,575
Before/After Data Collection and Management	\$1,244,300
TOTAL	\$7,700,000

PIP Implementation Schedule

The PIP implementation schedule includes activities that need to be completed prior to Go Live, as well as activities that will be ongoing during the Pilot's phases and potentially occur post-Pilot. Metro anticipates that it will take approximately eight months to complete all the pre-Go Live activities for Phase 1. Metro anticipates a 14-month operational period for each phase that includes a two-month "grace period" to mitigate potential confusion by customers. The decision to implement Phase 2 will be dependent on the performance evaluation data from Phase 1 as well as the readiness of the mobile app. A high-level PIP implementation schedule is in Section 3 (Figure 11).

Proposed PIP activities are described in Sections 7 (Pilot Implementation Plan Support Strategies), 8 (Comprehensive Outreach and Education Plan), 9 (Operational Considerations, and 10 (Data Collection and Analysis Plan) of this document, and they are further expanded upon in the Implementation Roadmap and Master Schedule in Appendix B.

Next Steps

Metro is prepared to implement the PIP and will begin preparing for Phase 1 upon Board approval. The estimated Timeline of Pilot Implementation Activities is provided below:

Timeline of Pilot Activities

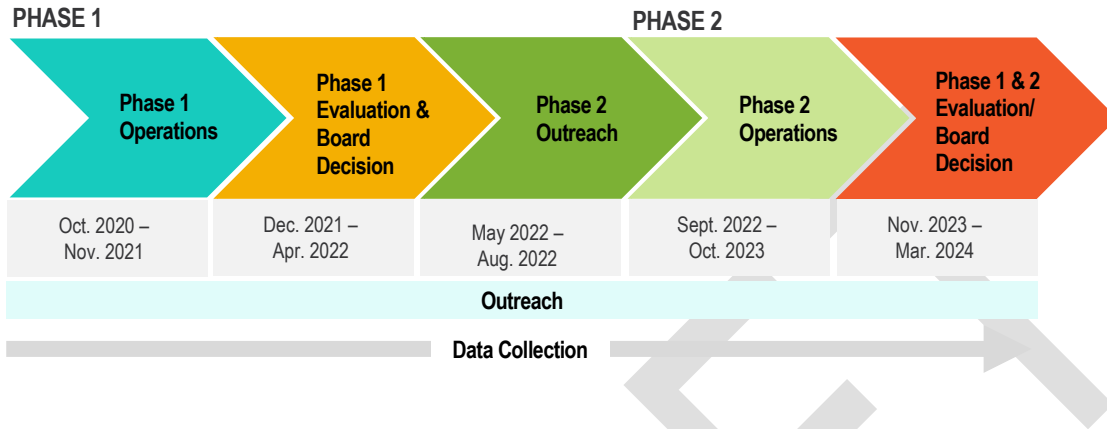



Metro

Los Angeles County
Metropolitan Transportation Authority

One Gateway Plaza
Los Angeles, CA 90012-2952

213.922.2000 Tel
metro.net

ATTACHMENT C

I-10 ExpressLanes/Busway Pilot Implementation Plan:
A Degradation Mitigation Strategy

Document Available Online At:

[http://libraryarchives.metro.net/DB_Attachments/200109_Attachment_C_Implementation_Plan.p
df](http://libraryarchives.metro.net/DB_Attachments/200109_Attachment_C_Implementation_Plan.pdf)



Board Report

File #: 2019-0870, **File Type:** Contract

Agenda Number: 27.

OPERATIONS, SAFETY, AND CUSTOMER EXPERIENCE COMMITTEE JANUARY 16, 2020

SUBJECT: REAL ESTATE MANAGEMENT SYSTEM

ACTION: AWARD CONTRACT

RECOMMENDATION

AUTHORIZE the Chief Executive Officer to award a six-year firm-fixed price Contract No. PS62371000 to Flairsoft Ltd. for the purchase of Real Estate Management System and software support services in the amount of \$946,463, plus optional licenses, modules and subscription maintenance and support of \$714,960 for a combined total amount of \$1,661,423, subject to resolution of protest(s), if any.

ISSUE

Metro is embarking on a significant growth in its real estate holdings as a result of capital infrastructure development outlined in Measure M. The Real Estate Department estimates that over 3,000 acquisitions and relocations are to be completed in the next ten years. Currently there is no electronic record management system or formal workflow for the acquisition of Metro property or planning of future real property acquisitions. In order to handle and improve process efficiencies, the department requires a new Real Estate Management System (REMS) to act as the principal work management solution.

BACKGROUND

The Real Estate Department's mission is to ensure optimal use of all Metro owned properties, maximize the value of each of these assets, acquire all needed property at the best possible value to the agency and keep the goal of efficient and effective public transit in Los Angeles County.

The department manages and administers over 5,000 real estate agreements spanning some 250 miles of Right-of-Way (ROW) throughout Los Angeles County and provides full-service property management for the Union Station Transit Hub. It is responsible for the full range of real estate services including appraisal, services, environmental investigations, acquisition/disposition of real estate for administrative and transit projects.

DISCUSSION

The proactive approach to implementing this system now will avoid costly errors in years to come from the sheer enormity of the task. It will inhibit long delays to right-of-way acquisition under tight schedules as currently defined by the projects in the department's portfolio. The implemented solution will have a fully developed platform for what is a highly defined and regulated business involving multiple processes. The solution's affordable technology stack will provide:

- A scalable solution which can be extended in the cloud for use by Metro contractors performing work on Metro's behalf
- An integrated GIS environment which can be distributed to multiple stakeholders to communicate status and provide a common operating picture for greater exchange among Planning, Real Estate, and Project Management
- A database with workflow integration based on multiple laws regulating public land acquisition & relocation

DETERMINATION OF SAFETY IMPACT

Approval of the contract award will ensure that the agency better complies with laws & regulations managing schedules, resources, risks, budgets and quality controls.

FINANCIAL IMPACT

Funding for this service has been approved under a capital project (CP 207157) and is included in the FY20 budget under cost center 9210, Information Management. Since this project will span over a year, the project manager and the Chief Information Technology Officer will be responsible for budgeting the cost in future years.

IMPACT TO BUDGET

The funding for this action will be a combination of federal, state and local operating funds.

IMPLEMENTATION OF STRATEGIC PLAN GOALS

Recommendation supports **Metro Vision 2028 Strategic Goal 5** - Provide responsive, accountable and trustworthy governance within the Metro organization.

ALTERNATIVES CONSIDERED

The Board may choose not to proceed with the contract award, however this is not recommended as Flairsoft fully meets the requirements in the RFP.

NEXT STEPS

Upon approval by the Board, staff will execute Contract No. PS62371000 with Flairsoft Ltd. for the purchase of Real Estate Management System and software support services.

ATTACHMENTS

Attachment A - Procurement Summary

Attachment B - DEOD Summary

Prepared by: Vahram Shahgaldian, Sr. Manager, ITS (213) 418-3468
John Potts, Executive Officer, Countrywide Planning and Development, (213) 418-3397

Reviewed by:
Bryan Sastokas, Chief Information Technology Officer, ITS (213) 922-5510
Debra Avila, Chief Vendor/Contract Management Officer, (213) 418-3051

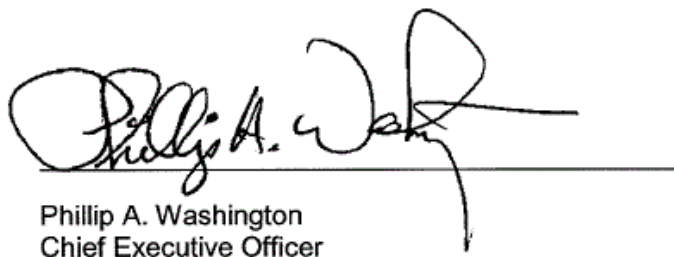

Phillip A. Washington
Chief Executive Officer

PROCUREMENT SUMMARY

REAL ESTATE MANAGEMENT SYSTEM/PS62371000

1.	Contract Number: PS62371000	
2.	Recommended Vendor: Flairsoft Ltd.	
3.	Type of Procurement (check one): <input type="checkbox"/> IFB <input checked="" type="checkbox"/> RFP <input type="checkbox"/> RFP-A&E <input type="checkbox"/> Non-Competitive <input type="checkbox"/> Modification <input type="checkbox"/> Task Order	
4.	Procurement Dates:	
	A. Issued: 6/17/2019	
	B. Advertised/Publicized: 6/18/2019	
	C. Pre-Proposal Conference: 6/26/2019	
	D. Proposals Due: 7/30/2019	
	E. Pre-Qualification Completed: 9/12/2019	
	F. Conflict of Interest Form Submitted to Ethics: 8/1/2019	
	G. Protest Period End Date: 1/21/2020	
5.	Solicitations Picked up/Downloaded: 34	Bids/Proposals Received: 1
6.	Contract Administrator: Manchi Yi	Telephone Number: (213) 418-3332
7.	Project Manager: Vahram Shahgaldian	Telephone Number: (213) 418-3468

A. Procurement Background

This Board Action is to approve Contract No. PS62371000 to Flairsoft Ltd. (Flairsoft) for the purchase of Real Estate Management System and software support services, including optional licenses, modules and subscription maintenance & support. Board approval of contract awards are subject to resolution of any properly submitted protest.

The Request for Proposal (RFP) was issued in accordance with Metro's Acquisition Policy and the contract type is a firm fixed price. The RFP was issued as a Small Business Set Aside procurement.

Two amendments were issued during the solicitation phase of this RFP:

- Amendment No. 1 was issued on June 19, 2019 to provide proposers an option to participate in the pre-proposal conference via conference call;
- Amendment No. 2 was issued on July 8, 2019 to extend the proposal due date to July 30, 2019.

A pre-proposal conference was held on June 26, 2019 and was attended by 12 participants representing six firms. There were 13 questions submitted and responses were released prior to the proposal due date.

A total of 34 firms downloaded the RFP and were included on the planholders' list. A single proposal was received on July 30, 2019 from Flairsoft. A market survey was conducted of the planholders to determine why there were no other proposers. The following is a summary of the market survey from potential proposers:

1. We are focusing our resources to respond to another more relevant RFP.
2. We felt intimidation for not having enough experience to perform the work. Additionally, we are a small three-man business.
3. We determined that our solutions were not the best fit for your organization's needs and decided not to submit a proposal.
4. Our understanding of the SOW was that an off-the-shelf solution was required. We develop custom solutions and as such do not have an off-the-shelf offering.
5. We felt we would not be able to "comply with the SBE Program requirements provided in the Diversity & Economic Opportunity Department Contract Compliance Manual (Set-Aside)."
6. We found the timeline required to be short as to our current capacity. The COTS vendors we interviewed also hesitated in partnering with a small agency such as ours.
7. Our technical staff No-Go'ed this opportunity due to the delivery structure and our inability to meet the basic RFP specifications.
8. We had gotten notice of the request for proposal late and had already committed our resources to another response.

B. Evaluation of Proposals

A Proposal Evaluation Team (PET) consisting of staff from the Information and Technology Services Department and Real Estate Department was convened and conducted a comprehensive technical evaluation of the proposal received.

The proposal was evaluated based on the following pass/fail minimum requirements and evaluation criteria and weights:

Pass/Fail Minimum Requirements

- Proposed REMS software must be installed and in operation in at least three (3) other establishments. Proposer shall provide references with contact information.
- Proposer's resources must have experience in configuring, integrating and supporting the proposed REMS software.

Evaluation Criteria and Weights

- | | |
|---|------------|
| • Proposer's Business & Service Profile | 10 percent |
| • Proposer Resource's Skillsets & Relevant Experience | 20 percent |
| • Technical Solution: REMS Requirements Goodness-of-Fit | 20 percent |
| • REMS Software Demonstration | 15 percent |
| • Project Methodology, Approach & Schedule | 10 percent |
| • Cost Proposal | 25 percent |

The evaluation criteria are appropriate and consistent with criteria developed for other similar software procurement.

The PET began its independent evaluation of Flairsoft's proposal in August. Flairsoft's proposal passed the minimum requirements and a software demonstration was held in early September. Flairsoft was required to demonstrate how their proposed software's functionality met the requirements of the RFP. Staff then requested several clarification meetings via phone conference. The PET concluded that Flairsoft's proposal was technically acceptable and met the requirements of the RFP.

The following table is a summary of the PET's scores.

1	Firm	Average Score	Factor Weight	Weighted Average Score	Rank
2	Flairsoft Ltd.				
3	Proposer's Business & Service Profile	92.00	10%	9.20	
4	Proposer Resource's Skillsets & Relevant Experience	90.00	20%	18.00	
5	Technical Solution: REMS Requirements Goodness-of-Fit	92.00	20%	18.40	
6	REMS Software Demonstration	83.00	15%	12.45	
7	Project Methodology, Approach & Schedule	90.00	10%	9.00	
8	Cost Proposal	100.00	25%	25.00	
9	Total		100%	92.05	1

C. Cost/Price Analysis

The recommended price has been determined to be fair and reasonable based upon an independent cost estimate (ICE), technical evaluation, fact finding, and negotiations. The original proposal amount is lower than the negotiated amount because optional modules and subscription maintenance and support were added during negotiations.

	Proposer Name	Proposal Amount	Metro ICE	Negotiated or NTE amount
1.	Flairsoft Ltd.	\$986,463	\$1,425,750 *	\$1,661,423

* ICE amount did not include optional modules or subscription maintain and support.

D. Background on Recommended Contractor

The recommended firm, Flairsoft, located in Columbus, Ohio, has been in business since 2001. Flairsoft has implemented and completed over 10 systems and has over 16 years of configuring, integrating and supporting Flairdocs Right-of-Way and Real Estate solution across government agencies, transportation, utilities, gas and pipeline companies. Government clients include Sound Transit, Oregon DOT, New York State Department of Transportation and Las Vegas Water District Authority.

DEOD SUMMARY

REAL ESTATE MANAGEMENT SYSTEM/PS62371000

A. Small Business Participation

Pursuant to Metro's Board-approved policy, competitive acquisitions with three or more Small Business Enterprise (SBE) certified firms within the specified North American Industry Classification System (NAICS) as identified for the project scope shall constitute a Small Business Set-Aside procurement. Accordingly, the Contract Administrator advanced the solicitation, including posting the solicitation on Metro's website, advertising, and notifying certified small businesses as identified by NAICS code(s) that this solicitation was open to SBE Certified Small Businesses Only.

Flairsoft LTD, an SBE Prime, is performing 96.87% of the work with its own workforce. Flairsoft LTD made a 96.87% SBE commitment.

SMALL BUSINESS PRIME (SET-ASIDE)

	SBE Prime Contractor	SBE % Committed
1.	Flairsoft LTD	96.87%
Total Commitment		96.87%

B. Living Wage and Service Contract Worker Retention Policy Applicability

The Living Wage and Service Contract Worker Retention Policy (LW/SCWRP) is not applicable to this contract.

C. Prevailing Wage Applicability

Prevailing wage is not applicable to this contract.

D. Project Labor Agreement/Construction Careers Policy

Project Labor Agreement/Construction Careers Policy is not applicable to this Contract. Project Labor Agreement/Construction Careers Policy is applicable only to construction contracts that have a construction contract value in excess of \$2.5 million.

Los Angeles County Metropolitan Transportation Authority

Real Estate Management System and software support services



INFORMATION AND
TECHNOLOGY SERVICES

Operations, Safety, And Customer Experience Committee

January 16, 2020

2019 – 0870

Real Estate Management System & software support services

Request to award a multiyear contract to Flairsoft Ltd for a Real Estate Management System for \$1,661,423.

❖ Metro will see significant growth in its real estate holdings as a result of capital infrastructure developments.

- The department currently manages and administers over 5,000 real estate agreements and estimates to add over 3,000 acquisitions in the next ten years.
- Metro does not have an electronic record management system.
- The new system will provide an integrated GIS environment, sanction greater exchange among groups and allow contractors to perform work on Metro's behalf.
- The system will increase functionality for tracking, managing & planning real estate acquisitions and ensure adherence to laws regulating public land acquisition & relocation.



Questions?



Board Report

File #: 2020-0021, File Type: Federal Legislation / State Legislation (Position)

Agenda Number: 38.

**REVISED
EXECUTIVE MANAGEMENT COMMITTEE
JANUARY 16, 2020**

SUBJECT: STATE LEGISLATION

ACTION: ADOPT STAFF RECOMMENDED POSITIONS

RECOMMENDATION

ADOPT staff recommended positions:

- A. ~~Senate Bill 732 (Allen) – Transactions and use tax: South Coast Air Quality Management District.~~ **SUPPORT**
- B. Assembly Bill 1350 (Gonzalez) - Free youth transit passes: eligibility for state funding. **WORK WITH AUTHOR**

ATTACHMENT

- ~~Attachment A – Senate Bill 732 (Allen) Legislative Analysis~~
- Attachment B - Assembly Bill 1350 (Gonzalez) Legislative Analysis

Prepared by: Michael Turner, DEO, Government Relations, (213) 922-2122

Reviewed by: Yvette Rapose, Chief Communications Officer, (213) 418-3154

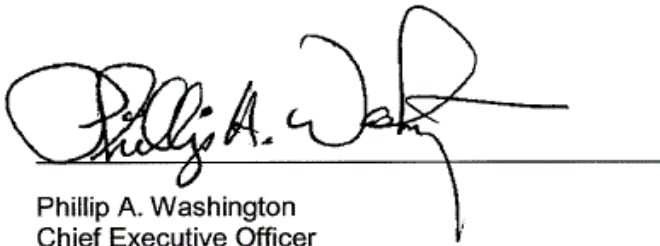

Phillip A. Washington
Chief Executive Officer

ATTACHMENT B

BILL: ASSEMBLY BILL 1350
AS AMENDED 1/6/2020

AUTHOR: ASSEMBLYMEMBER LORENA GONZALEZ (D-SAN DIEGO)

SUBJECT: FREE YOUTH TRANSIT PASSES: ELIGIBILITY FOR STATE FUNDING.

STATUS: ASSEMBLY TRANSPORTATION COMMITTEE
HEARING SCHEDULED: JANUARY 13, 2020

ACTION: WORK WITH AUTHOR

RECOMMENDATION

Staff recommends that the Board of Directors adopt a WORK WITH AUTHOR position on Assembly Bill 1350 (Gonzalez) as amended January 6, 2020.

ISSUE

This bill was amended on January 6, 2020 to add provisions related to transportation funding to the Public Utilities Code.

Specifically the bill would:

- Require transit agencies to offer free youth transit passes to persons under 18 years of age in order to be eligible for state funding under the Mills-Deddeh Transit Development Act, the State Transit Assistance Program, or the Low Carbon Transit Operations Program.
- Require a free youth transit pass to count as a full price fare for purposes of calculating the ratio of fare revenues to operating costs.

DISCUSSION

AB 1350 (Gonzalez) is a two-year bill that was recently amended. The amendments of January 6, 2020 would require that transit agencies to provide free fares for students under the age of 18 in order to receive funding from the State Transit Assistance Program Transportation Development Act and the Low Carbon Transit Operations Program to a requirement.

The Board has previously supported efforts to assist students in particular who ride our system. The Board's support has been directed towards creating incentives or increased funding. AB 1350 takes a different approach by creating a mandate. It should also be noted that as a part of our Congestion Reduction initiative, Metro is pursuing a strategy that could achieve a similar objective. Staff would suggest that while we would support increasing assistance for those in need who ride our system there may be other ways to achieve this objective. We would like to work with the Assembly Member to explore more appropriate to identify additional state funding or other mechanisms that could be provided rather than pursuing this objective through a mandate.

Staff is working internally with relevant Metro departments to evaluate the impacts of the enactment of this legislation to Metro's current funding allocations under the TDA and LCTOP, and the administration of U-Pass, Reduced Fare and System Security programs. Staff will also work through the California Transit Association to address potential concerns with the proposal.

For these reasons, staff recommends that the Board adopt a WORK WITH AUTHOR position on AB 1350 (Gonzalez).

DETERMINATION OF SAFETY IMPACT

Allowing free rides on a transit system may have impacts to safety and security on our system. We would like to work with the author to address those concerns should the legislation proceed.

FINANCIAL IMPACT

The estimated financial impact of this action is still being evaluated.

IMPLEMENTATION OF STRATEGIC PLAN GOALS

Staff recommendation supports strategic plan goal # 4.2: Metro will help drive mobility agendas, discussions and policies at the state, regional and national levels.

ALTERNATIVES CONSIDERED

Staff has considered adopting either a support or oppose position on the bill. A support or oppose position would be inconsistent with Metro's Board approved 2020 State Legislative Program Goal #1: ensure the state continues to secure, protect and fully fund the major transportation programs in the state with existing commitments.

NEXT STEPS

Should the Board decide to adopt a WORK WITH AUTHOR position on this legislation; staff will communicate the Board's position to the author and work to ensure inclusion of the Board's priorities in the final version of the bill. Staff will continue to keep the Board informed as this issue is addressed throughout the legislative session.



Board Report

File #: 2020-0008, **File Type:** Contract

Agenda Number: 41.

**EXECUTIVE MANAGEMENT COMMITTEE
JANUARY 16, 2020**

SUBJECT: WEST SANTA ANA BRANCH P3 BUSINESS CASE FINANCIAL ADVISORY SERVICES

ACTION: APPROVE RECOMMENDATIONS

RECOMMENDATION

AUTHORIZE the Chief Executive Officer (CEO) to:

- A. EXECUTE Modification No. 3 to Task Order No. PS 50315-3049000 with Sperry Capital Inc. in the amount of \$1,258,650 to continue to support P3 Business Case Development for the West Santa Ana Branch LRT, increasing the not-to-exceed Task Order value from \$2,077,010 to \$3,335,660;
- B. INCREASE Contract Modification Authority (CMA) by \$267,605 from \$100,000 to \$367,605 in support of any unforeseen required additional level of effort

ISSUE

Task Order No. PS50315-3049000 currently provides for P3 Financial Advisory Services to support development of a P3 Business Case for the West Santa Ana Branch Light Rail Transit Project (“WSAB” or “the Project”).

Staff is requesting a modification in the amount of \$1,258,650 for Task Order No. PS50315-3049000 to support pre-procurement activities for the Project, including finalization of a P3 Business Case, and development and structuring of procurement and commercial documents. Staff is requesting an increase in CMA by \$267,605 to account for any additional unforeseen expenses or required level of effort, to be utilized with appropriate justification.

BACKGROUND

The P3 Business Case is a comprehensive approach, utilized as a best practice worldwide by public agencies for major capital investments to identify, assess and make a recommendation on the appropriate procurement option for a project that is likely to best achieve the project objectives and maximize value for money. A P3 business case will identify and assess a range of alternative procurement models (i.e., models that are different than the traditional design-bid-build or design-build approaches) and make a recommendation on an optimal procurement model to be pursued along with a credible plan for implementation.

Key tasks in support of a P3 Business Case include:

1. Review and analyze existing project information
2. Shortlist procurement options for assessment
3. Qualitative assessment of procurement options
4. Market soundings and industry engagement
5. Project cost identification and financial modelling
6. Risk assessment and quantification
7. Quantitative Value for Money Assessment
8. Funding and affordability analysis

DISCUSSION

Metro awarded Task Order No. PS50315-3049000 to support development of a Business Case Report for WSAB in February 2018. At that time, Metro was considering a defined range of alternatives for the project, and had established a well-developed schedule for further project definition and development through the conceptual engineering and environmental clearance process. Since then, the project has been rescope due to community feedback regarding the alignment and configuration and additional project information has been developed, adding to the complexity of the effort, and resulting in a prior contract modification.

A full value-for-money analysis for the WSAB project alignment from Artesia to Downtown remains underway. Project team analysis has also identified that overall costs for an accelerated project were greater than anticipated in the Measure M Expenditure Plan, resulting in a funding gap. This information has been previously presented to the Board in quarterly staff updates on the "Pillar Projects."

Based in part on findings from high-level risk and financial assessments on various project alternatives authorized by the previous Task Order modification, taking into account the funding gap, Metro has identified a defined scope (alignment, configuration, and termini) for the West Santa Ana Branch that is likely the most feasible option for early delivery of the project.

This project option, which was not developed at the time the Task Order, or prior Task Order modification was issued, must now be incorporated into the draft Business Case. As a result, OEI and its P3 Financial Advisory Consultant must reorient financial analysis supporting a final P3 Business Case to incorporate this newly defined scope option. This contract modification will allow Metro to ensure the Business Case analysis fully considered the defined interim operating segment (IOS) alternatives, in addition to the ongoing analysis on the full Downtown-Artesia alignment.

This will support Metro staff's efforts to confirm P3 value for money and support structuring of the P3 solicitation and contract documents, activities which will occur in parallel. This effort will support a P3 commercial structure and procurement that can optimize project value. It will also support efforts to identify and obtain federal financial support.

This modification will have no impact on the ongoing environmental process, which will evaluate the entire proposed WSAB alignment, from Downtown to Artesia, including the two Interim Operating Segments. After the release of the draft environmental document, the Board will select the Locally Preferred Alternative to be carried forward into the final environmental document.

Based on the expected schedule for project development, staff anticipates additional tasks and deliverables will be required to support a robust Business Case Report. These have been outlined in a supplemental statement of work.

DETERMINATION OF SAFETY IMPACT

This action will have no impact on safety for Metro.

FINANCIAL IMPACT

This Task Order is allocated to Cost Center 2031 - Public Private Partnerships, account 50316. Funding of \$5,558,000 was budgeted for P3 Professional Advisory Services under this account in FY 2020. To date in FY 2020, \$4,069,196 has been encumbered and \$1,457,806.63 has been expended, with \$4,100,193.37 remaining in the budget. Since sufficient value remains on the underlying contract and in the fiscal year budget, the cost center manager and Chief Innovation Officer will be accountable for budgeting the cost.

IMPACT TO BUDGET

The current year funding for this action will come from General Fund revenues. These funds are eligible for Bus and Rail Operating projects. No other funds were considered for this project. Since this is a multi-year project, it will be the responsibility of the department to budget for these funds in future years.

IMPLEMENTATION OF STRATEGIC PLAN GOALS

The Metro Vision 2028 Strategic Plan identifies five goals to guide Metro's work and initiatives. This modification supports the following goals.

- ***Goal 1: Provide high-quality mobility options that enable people to spend less time traveling.***
Allowing Metro's P3 Financial Consultants to support further P3 Business Case Development for the expanded scope of the WSAB project definition will allow Metro to seek ways to deliver this project faster, to identify potential project savings, and to ensure project performance throughout its lifecycle.
- ***Goal 2: Deliver outstanding trip experiences for all users of the transportation system.***

A key benefit of P3 delivery is higher guaranteed project performance (reliability, safety, cleanliness, etc.).

- **Goal 5. Provide responsive, accountable, and trustworthy governance within the Metro organization.**

P3s have been shown to achieve higher levels of schedule and funding certainty, supporting Goal 5.2 to exercise good public policy judgment and sound fiscal stewardship

ALTERNATIVES CONSIDERED

Staff considered limiting analysis to the existing level of reliability. However, this would not have supported a Business Case Report offering identification of key value drivers or reliability for commercial structuring and procurement.

Staff also considered moving forward without a full Business Case, but has noted that to execute a high-quality P3 transaction requires the due diligence presented in a robust Business Case. Moving forward with incomplete information would likely undermine the success of a P3 transaction.

Staff's assessment indicated that none of these options were a cost-effective or financially sound option for Metro.

NEXT STEPS

Upon Board approval, staff will execute Modification No. 3 to Task Order No. PS 50315-3049000 with Sperry Capital Inc. to finalize the Business Case for the West Santa Ana Branch LRT project on the identified project scope.

ATTACHMENTS

Attachment A - Procurement Summary

Attachment B - Task Order Modification/Change Order Log

Attachment C - DEOD Summary

Prepared by: Colin Peppard, Senior Director, Special Projects, (213) 418-3434

Reviewed by: Debra Avila, Chief, Vendor/Contract Management Officer, (213)
418-3051

Joshua Schank, Chief Innovation Officer, (213) 418-3345

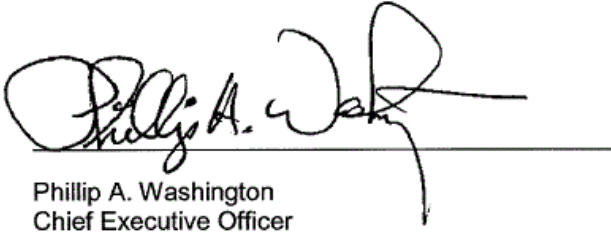

Phillip A. Washington
Chief Executive Officer

PROCUREMENT SUMMARY

Financial Advisory Services: Business Case Development and Pre-Procurement Support for the West Santa Ana Branch Light Rail Transit Project/PS50315-3049000

1.	Contract Number: Task Order No. PS50315-3049000		
2.	Contractor: Sperry Capital Inc.		
3.	Mod. Work Description: To finalize the Business Case for the West Santa Ana Branch Light Rail Transit Project.		
4.	Task Order (TO) Work Description: Financial Advisory Services: Business Case Development and Pre-Procurement Support for the West Santa Ana Light Rail Transit Project Agreement.		
5.	The following data is current as of: 12/13/19		
6.	TO Completion Status		Financial Status
	TO Awarded:	02/23/18	TO Award Amount: \$1,000,000
	Notice to Proceed (NTP):	02/23/18	Total of Modifications Approved: \$1,077,010
	Original Complete Date:	02/28/20	Pending Modifications (including this action): \$1,258,650
	Current Est. Complete Date:	12/31/21	Current TO Value (with this action): \$3,335,660
7.	Contract Administrator: Lily Lopez		Telephone Number: (213) 922-4639
8.	Project Manager: Colin Peppard		Telephone Number: (213) 418-3434

A. Procurement Background

This Board Action is to approve Modification No. 3 to Task Order No. PS50315-3049000 to provide financial advisory services in order to prepare a P3 Business Case for the West Santa Ana Branch Light Rail Transit Project, as well as to assist with other pre-procurement activities, including general strategic advisory on the procurement process for the project to help maximize achievement of Metro's project goals. This Modification will require the Contractor to continue finalizing the Business Case for the West Santa Ana Branch Light Rail Transit Project and will also extend the period of performance through December 31, 2021.

This Task Order Modification was processed in accordance with Metro's Acquisition Policy. The contract/task order type is firm fixed price. All other terms and conditions remain in effect.

On February 23, 2018, Task Order No. PS50315-3049000 in the amount of \$1,000,000 was issued to Sperry Capital Inc., under the Public-Private Partnership Technical Bench, Discipline 6 (Financial Analysis) for Financial Advisory Services:

Business Case Development and Pre-Procurement Support for the West Santa Ana Light Rail Transit Project.

Refer to Attachment B – Task Order Modification/Change Order Log for modifications issued to date.

B. Cost Analysis

The recommended price has been determined to be fair and reasonable based upon an independent cost estimate (ICE), cost analysis, and technical analysis. Metro’s ICE overestimated the level of effort required to conduct the value for money assessment and business case development. All labor rates remain unchanged from the original task order.

Proposal Amount	Metro ICE	Negotiated Amount
\$1,258,650	\$1,338,025	\$1,258,650

ATTACHMENT B

**TASK ORDER MODIFICATION/CHANGE ORDER LOG
PUBLIC-PRIVATE PARTNERSHIP TECHNICAL BENCH/
TASK ORDER NO. PS50315-3049000
TASK ORDER LOG VALUE ISSUED TO DATE**

Mod. No.	Description	Status (approved or pending)	Date	Amount
1	Provided supplemental market sounding, preliminary financial analysis, project risk analysis and FTA expedited project delivery grant support.	Approved	01/22/19	\$99,970
2	To finalize the Business Case for the West Santa Ana Branch Light Rail Transit Project.	Approved	04/25/19	\$977,040
3	To continue finalizing the Business Case for the West Santa Ana Branch Light Rail Transit Project and extending the period of performance through December 31, 2021.	Pending	Pending	\$1,258,650
	Task Order Modification Total:			\$2,335,660
	Original Task Order Amount:		02/23/18	\$1,000,000
	Total:			\$3,335,660

DEOD SUMMARY

Financial Advisory Services: Business Case Development and Pre-Procurement Support for the West Santa Ana Light Rail Transit Project/PS50315-3049000

A. Small Business Participation

Sperry Capital Inc. (Sperry), an SBE Prime, made a 34.63% Small Business Enterprise (SBE) commitment. The project is 93% complete and Sperry is exceeding its SBE commitment with a current SBE participation of 36.31%. DEOD reached out to Sperry about the under-utilization of their SBE subcontractor, NWC Partners, Inc. (NWC). Sperry indicated that NWC is a specialty consulting firm and the expected tasks that were envisioned for NWC have not materialized to the degree anticipated in the initial scope. Sperry also indicated they expect increased utilization of NWC on Contract Modification No. 3 with the additional task of Federal Financial Instrument Support.

Small Business Commitment	34.63% SBE	Small Business Participation	36.31% SBE
----------------------------------	-------------------	-------------------------------------	-------------------

	SBE Subcontractors	% Committed	Current Participation¹
1.	Sperry Capital Inc. (SBE Prime)	31.26%	35.96%
2.	NWC Partners, Inc.	3.37%	0.35%
	Total	34.63%	36.31%

¹Current Participation = Total Actual amount Paid-to-Date to DBE firms ÷ Total Actual Amount Paid-to-date to Prime.

B. Living Wage and Service Contract Worker Retention Policy Applicability

The Living Wage and Service Contract Worker Retention Policy (LW/SCWRP) is not applicable to this modification.

C. Prevailing Wage Applicability

Prevailing wage is no applicable to this modification

D. Project Labor Agreement/Construction Careers Policy

Project Labor Agreement/Construction Careers Policy is not applicable to this Contract. Project Labor Agreement/Construction Careers Policy is applicable only to construction contracts that have a construction contract value in excess of \$2.5 million.

**Board Report**

File #: 2019-0873, **File Type:** Contract**Agenda Number:** 42.

**EXECUTIVE MANAGEMENT COMMITTEE
JANUARY 16, 2020****SUBJECT: ACQUISITION OF COMPUTER HARDWARE, SOFTWARE AND SERVICES
ACTION: APPROVE RECOMMENDATION****RECOMMENDATION**

AUTHORIZE the Chief Executive Officer to utilize the National Association of State Procurement Officials (NASPO) cooperative purchase program to purchase computer and network equipment, peripherals, and related software and services, for a five-year period for a total expenditure not-to-exceed \$30,000,000, subject to funding availability effective Feb 1, 2020.

ISSUE

In July 2014, the Board of Directors approved the acquisition of computer hardware, software, and services through the Western States Contracting Alliance (WSCA) Master Price Agreement, for a five-year period beginning on Aug 1, 2014, in an amount not-to-exceed \$22,500,000. The Board of Directors approval has expired. The contract was successfully utilized over the last five years. As of July 2019, 124 awards were executed and a total of \$20,400,992.11 had been expended.

The recent growth of Metro's technology infrastructure (e.g., computer & server processing equipment, network & data telecommunication equipment, electronic file storage systems, audio visual & security systems) are being driven through the delivery of current Transit, Highway, Regional Rail, Program Management and Union Station Projects. Based on current and planned projects scheduled for the next five years, we are requesting a Board authority level required to meet these needs.

BACKGROUND

The National Association of State Procurement Officials (NASPO, formally WSCA), is a non-profit association dedicated to advancing public procurement through leadership, excellence, and integrity. It is made up of the directors of the central purchasing offices in each of the 50 states, the District of Columbia and the territories of the United States. By leveraging their national negotiation and buying

power (over 12 billion dollars in sales annually), NASPO delivers the highest valued, reliable and competitively sourced contracts offering public entities outstanding prices.

They work and negotiate directly with the original equipment manufacturers (OEM), to negotiate the best competitive pricing. Overall, working through NASPO program provides the best overall value, best prices, best terms and condition (including quality, delivery, return policy, insurance, performance, and warranty) and best solutions, that exceeds those possible for any single state.

In addition to cooperative contracts and collective buying power, Metro will have other benefits. These benefits include participating in NASPO training, education, professional development, research, innovative procurement strategies, conferences, procurement best practices and collaboration with other members to achieve success as public procurement leaders.

With their vast years of experience and no membership or administrative application of fees, NASPO has become the nation's premier public purchasing cooperative and the largest public purchasing cooperative in the country.

DISCUSSION

Use of NASPO has shown to be effective in streamlining computer product acquisitions by leveraging buying power to obtain lower pricing and lower administrative costs through shortened processing time. For example, by leveraging the competitive process that NASPO has already gone through, purchasing equipment through the NASPO Master Price Agreement can be accomplished in approximately 1-2 weeks versus the 6-8 weeks or longer for the Metro bid process. Based on the reduced administrative time savings, more timely purchasing cycle time and competitive volume pricing achieved, staff is recommending continued use of this procurement vehicle to sustain these objectives. Furthermore, items typically purchased under NASPO are Metro ITS standard equipment such as Dell computers, IBM servers, Cisco network devices, and the engineering implementation services related to this equipment.

Metro has significantly increased its use of computers to streamline and automate many of its business processes and functions to increase efficiency and reduce cycle time. Due to the dependence on computer technology to support its business operations, a replenishment process has been established to optimize and maintain the effective operation of Metro's inventory of computers, servers and network equipment and related software applications. Non-replacement of aging computer hardware and software systems will ultimately result in increased system unavailability affecting the ability of Metro to efficiently support its daily business operations, such as transit operations, vehicle maintenance, inventory management, human resources, and procurement.

DETERMINATION OF SAFETY IMPACT

Procurement is a critical component for all project delivery success. Technology supports all areas of communications, day to day business operations and security. The ability to grow, enhance and

maintain the state of good repair of our technology equipment and services are critical to ensuring the confidential, integrity and availability of Metro's information systems and data and safety to our patrons.

FINANCIAL IMPACT

There is no increased cost, however, Metro should realize a decrease in costs for implementing this change.

Impact to Budget

Funding for these services are included under the Information Technology and Services departmental budget through various preapproved operating and capital budgets sourcing from a combination of local operating, state and federal funding sources. Since this is a multi-year project, the Project Manager and Chief Information Technology Officer are responsible for budgeting the cost in future years.

IMPLEMENTATION OF STRATEGIC PLAN GOALS

Recommendation supports Metro Vision 2028 Strategic Goal 5 - Provide responsive, accountable and trustworthy governance within the Metro organization.

ALTERNATIVES CONSIDERED

The alternative is to formally compete individual procurements via Invitation for Bids (IFBs) or Requests for Proposals (RFPs). This process is more time consuming and expensive when compared to the benefits of utilizing vendors already selected under a competitive contracting process conducted by the National Association of State Procurement Officials (NASPO).

NEXT STEPS

Upon Board approval, staff will move forward in the procurement of computers, servers and network equipment and related software through the National Association of State Procurement Officials (NASPO).

ATTACHMENTS

Attachment A - Procurement Summary
Attachment B - DEOD Summary

Prepared by: Bill Balter, Sr. Director - ITS PMO, (213) 922-4511

Reviewed by: Bryan Sastokas, Chief Information Technology Officer, (213) 922-4510
Debra Avila, Chief, Vendor/Contract Management (213) 418-3051

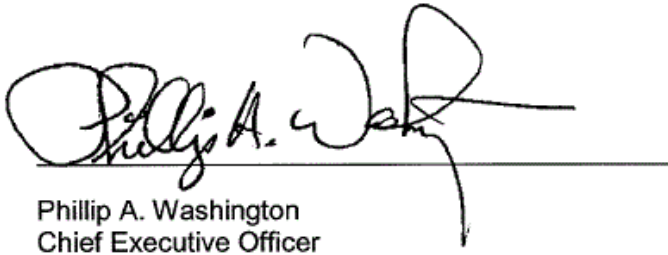

Phillip A. Washington
Chief Executive Officer

PROCUREMENT SUMMARY

NATIONAL ASSOCIATION OF STATE PROCUREMENT OFFICIALS (NASPO)

1.	Contract Number: N/A	
2.	Recommended Vendor: National Association of State Procurement Officials	
3.	Type of Procurement (check one): <input type="checkbox"/> IFB <input type="checkbox"/> RFP <input type="checkbox"/> RFP-A&E <input type="checkbox"/> Non-Competitive <input type="checkbox"/> Modification <input type="checkbox"/> Task Order	
4.	Procurement Dates:	
	A. Issued: N/A	
	B. Advertised/Publicized: N/A	
	C. Pre-Proposal Conference: N/A	
	D. Proposals Due: N/A	
	E. Pre-Qualification Completed: N/A	
	F. Conflict of Interest Form Submitted to Ethics: N/A	
	G. Protest Period End Date: N/A	
5.	Solicitations Picked up/Downloaded: N/A	Bids/Proposals Received: N/A
6.	Contract Administrator: Mark Lu	Telephone Number: 213-922-4689
7.	Project Manager: Bill Balter	Telephone Number: 213-922-4511

A. Procurement Background

NASPO ValuePoint is the cooperative contracting arm of the National Association of State Procurement Officials (NASPO), a non-profit organization formed in 1947, comprised of the Chief Procurement Officials of all 50 states and the U.S. Territories, to promote public procurement throughout the country. The NASPO ValuePoint Master Agreements are competitively solicited using a Lead State™ model, supported by a Sourcing Team™ comprised of multiple state procurement representatives and subject matter experts; leveraging the expertise and buying power of the many states and other participating entities.

B. Evaluation of Proposals

Price evaluations are performed at the individual purchase order level in accordance with the technical requirements listed for the projects.

C. Cost/Price Analysis

Most favorable pricing is obtained through competition performed by NASPO, and prices will be deemed fair and reasonable at the individual purchase order level.

D. Background on Recommended Contractor

NASPO ValuePoint Master Agreements are used by participating states and local governmental agencies. Master Agreements have been negotiated with all major IT related equipment and service providers.

DEOD SUMMARY

NATIONAL ASSOCIATION OF STATE PROCUREMENT OFFICIALS (NASPO)

A. Small Business Participation

The Diversity and Economic Opportunity Department (DEOD) will not establish a Disadvantaged Business Enterprise (DBE)/Small Business Enterprise (SBE) goals for the National Association of State Procurement Officials (NASPO) ValuePoint cooperative purchasing program. Only NASPO approved contractors and suppliers can bid on solicitations.

B. Living Wage and Service Contract Worker Retention Policy Applicability

The Living Wage and Service Contract Worker Retention Policy (LW/SCWRP) is not applicable to this contract.

C. Prevailing Wage Applicability

Prevailing wage is not applicable to this contract.

D. Project Labor Agreement/Construction Careers Policy

Project Labor Agreement/Construction Careers Policy is not applicable to this Contract. Project Labor Agreement/Construction Careers Policy is applicable only to construction contracts that have a construction contract value in excess of \$2.5 million.



Board Report

File #: 2019-0879, **File Type:** Program

Agenda Number: 43.

**EXECUTIVE MANAGEMENT COMMITTEE
JANUARY 16, 2020**

SUBJECT: ESTABLISH K-12 U-PASS PRICING AND CONTINUE REGIONAL U-PASS PROGRAM

ACTION: APPROVE RECOMMENDATIONS

RECOMMENDATION

APPROVE

1. The establishment of a K-12 pricing structure for the Universal Student Pass (U-Pass) Program for homeless student services programs at \$0.75 per boarding to match the college program, capped at \$24 per month for Metro boardings to match the existing K-12 Reduced Fare monthly pass.
2. The continuation of the Regional U-Pass Program for College/Vocational schools at the existing rate, which is each agency's college fare rate, up to \$0.75 per Boarding, capped at \$43 per month to match the College/Vocational Reduced Fare monthly pass.
3. The establishment of a Regional K-12 pricing structure for homeless student services programs, which is each agency's K-12 fare up to \$0.75 per boarding, capped at the highest monthly K-12 fare rate of all agencies used by the institution's students or \$40 per month, which is the highest monthly K-12 fare in the region, if no K-12 monthly fare exists at those agencies

ISSUE

As part of an ongoing effort to pursue strategies to increase student transit ridership, motion 49.1 requested an assessment of the feasibility of piloting a Universal Community College Student Transit Pass Program (See Attachment A).

The U-Pass Pilot Program ran for two years from Fall 2016 through Summer 2018 and U-Pass became a permanent program effective Fall 2018.

DISCUSSION

Since the launch of the U-Pass program, Metro has increased its partnerships from four schools to 21 schools (425%) and has increased participants 72% from 7,402 riders to 12,752 riders.

The U-Pass program was originally designed to partner with community colleges, universities and trade schools to utilize technology and improve accessibility to reduced fares to increase student ridership, while keeping costs low for students. Students of participating schools can purchase semester passes online or on campus. They receive a sticker with an embedded TAP chip, which turns their student ID into a TAP card that can be renewed each semester. Schools partner with Metro in co-branded marketing efforts and collect payments from students to fund the program. At the end of the semester, the schools are only billed for actual rides taken by students at the reduced rate of up to \$0.75 per boarding and the maximum charge is capped at the equivalent of \$43 per student per month (\$10.03 per week) to match the existing College/Vocational Reduced Fare.

Staff has created boilerplate Memoranda of Understanding (MOUs) approved by County Counsel and standard administrative procedures to make the U-Pass Program easy to implement, while also placing a high value on allowing schools to administer the program in the way that works best on their individual campuses.

As of Fall 2019, Metro launched the first K-12 Pilot Program at Manual Arts High School (MAHS). Through a grant from the 11th Hour Schmidt Family Foundation administered by Move LA and LA Promise Fund, passes were purchased for the Junior class at MAHS for the entire academic year (40 weeks) at a cost equivalent to the K-12 monthly reduced fare rate of \$24 per month or \$5.60 per week. Participation in the K-12 Pilot Program requires completion of Metro's K-12 application, which includes parental permission.

Los Angeles Unified School District (LAUSD) and Pasadena Unified School District (PUSD) have both contacted Metro to get permission to use the U-Pass program format to purchase passes for their homeless student populations as required under the McKinney-Vento Homeless Assistance Act. LAUSD has an estimated 18,000 homeless students and PUSD has an estimated 850 homeless students that receive free services from the district. As a result of tokens being phased out in November 2019, providing this assistance has become more challenging for schools and districts. Because this student population is more fluid and transit pass usage is likely to be less consistent, the U-Pass format of the school or district paying a per boarding cost capped at the equivalent of the monthly pass cost would work better than purchasing monthly passes for all participants.

Staff is recommending implementing the U-Pass option for homeless student services programs at K-12 schools by doing the following:

1. Invoice K-12 schools the at the same per boarding rate as the colleges, which is the agency's student rate up to \$0.75 per boarding (per the chart below, there are four agencies that have a K-12 fare lower than \$0.75, and the remaining U-Pass agencies and Metro would be invoiced at \$0.75 per boarding); and
2. Cap the average monthly cost at the board-approved K-12 monthly reduced fare rate,

which is currently \$24 per month or \$5.60 per week. If the Board changes the K-12 monthly fare rate in the future, the K-12 U-Pass monthly cap would also change accordingly.

Other Transit Agencies' K-12 Per Boarding Fare	
Culver CityBus	\$0.50 per boarding
GTrans	\$0.70 per boarding
Montebello Bus	\$0.75 per boarding
Pasadena Transit	\$0.50 per boarding
Torrance Transit:	\$0.50 per boarding

The pricing structure above does not represent a change in either the U-Pass per boarding rate or the K-12 monthly fare rate. Currently, the \$24 K-12 monthly fare rate only covers boardings on Metro and the U-Passes are valid on Metro and ten additional transit agencies. Therefore, if the K-12 U-Passes are used on regional transit agencies, and the cost to cover the Metro boardings and reimburse boardings on other agencies exceeds the \$24 monthly cap, then staff is recommending that the additional charges be handled as outlined in the following section.

Regional U-Pass

Metro currently has signed reimbursement agreements with ten additional transit agencies, where the agency adds U-Pass products to their fareboxes and Metro reimburses the agency for the fare for all U-Pass boardings at the end of each semester at the U-Pass rate or their current college rate, whichever is lower. These agencies are: Big Blue Bus, Culver CityBus, Glendale Beeline, GTrans, LADOT DASH, Long Beach Transit, Norwalk Transit, Montebello Bus, Pasadena Transit and Torrance Transit. Additional transit agencies have also expressed interest in joining the U-Pass Program. These boardings are included at no additional charge under the college U-Pass, and thus far the cost to reimburse other transit agencies has not exceeded the revenue collected for those boardings. Staff will continue to work with regional transit agencies and Metro's Office of Management and Budget (OMB) to determine if future pricing adjustments need to be made to the college Regional U-Pass based on the cost of reimbursing the other agencies and will seek Board approval if fare adjustments are required. Under this recommendation, K-12 Boardings would be reimbursed at the agency's K-12 per boarding fare up to \$0.75.

However, due to the lower monthly fare cap for K-12 boardings, the lower revenue generated by the K-12 U-Pass may not be enough to reimburse the other transit agencies at their full rate without charging additional costs to the participating schools or districts. Staff is proposing that the cost for Metro boardings be capped at the equivalent of the Metro K-12 monthly reduced fare rate, which is \$24 per month or \$5.60 per week. If the cost to reimburse additional transit agencies exceeds \$24 per month, staff is proposing that the institution be invoiced for the overage, with the total average cost capped at the monthly K-12 rate of the agencies used during the semester pass period, if one exists. For instance, if a school's students used only Metro and Torrance Transit, the cost would be

capped at the monthly equivalent of \$30 per month (\$7 per week) per student (see agencies' established K-12 monthly rates below). If a K-12 monthly rate has not been established by the agency or if the boardings were used on multiple agencies, staff is recommending the total cost be capped at an average of \$40 per month (\$9.33 per week) per student, which is the highest monthly K-12 fare in the region (see chart below). As of Spring 2019, 91% of all Regional U-Pass boardings were used on Metro services, and the total amount reimbursed to other agencies was only \$101,947.10 of over \$1.2 million collected in U-Pass Fare Revenue.

Other Transit Agencies' Monthly K-12 Reduced Fare	
Big Blue Bus	\$30 Youth 30-Day Pass
Foothill Transit	\$36 31-Day Pass
Glendale Beeline	\$22 31-Day Pass
Long Beach Transit	\$40 Monthly Student Pass
Montebello Bus	\$30 Monthly Student Pass
Torrance Transit	\$30 Monthly Student Pass

DETERMINATION OF SAFETY IMPACT

This program does not affect the incidence of injuries or healthful conditions for patrons or employees. Therefore, approval of this request will have no impact on safety.

FINANCIAL IMPACT

In FY '19, the U-Pass Program generated \$2.7 million in total revenue and paid \$112,595 in reimbursements to other agencies.

Impact to Budget

The funding source for the MCS programs is Enterprise Fund operating revenues including sales tax and fares. The source of funds for this action, operating revenues, is eligible to fund bus and rail operating and capital expenditures.

The continued expansion and support of the U-Pass program may warrant an evaluation of the staffing for future years as part of the budget process.

ALTERNATIVES CONSIDERED

1. Metro will continue to offer the regular monthly College/Vocational and K-12 Reduced Fare Passes for students and schools not participating in the U-Pass pilot program.

NEXT STEPS

1. Establish long-term contracts with new K-12 U-Pass schools to support homeless student services programs.
2. Continue to grow ridership at all partner schools by 10% each year.
3. Continue to seek additional funding to further reduce the cost of the program to schools and will work with schools to identify other sources of funding such as grants, parking fees and/or fines, student association fees, and/or activity fees and/or referendums and as a means of subsidizing the program.
4. Continue to partner with schools to address transit service and service alignment issues.

ATTACHMENTS

Attachment A - File #:2016-0333, Board Report on Approve Adoption of Universal College Student Transit Pass (U-Pass) Pilot in response to Motion 49.1

Prepared by: Devon Deming, Dir. of Metro Commute Services, (213) 922-7957
Jocelyn Feliciano, Communications Manager, (213) 922-3895

Reviewed by: Yvette Rapose, Chief Communications Officer, (213) 418-3154

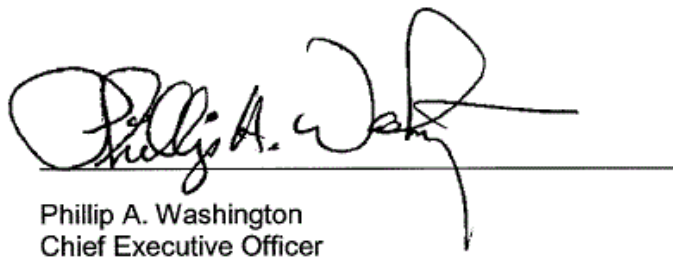

Phillip A. Washington
Chief Executive Officer

**Board Report**

File #:2016-0333, **File Type:**Program

Agenda Number:

**REGULAR BOARD MEETING
MAY 26, 2016****SUBJECT: COMMUNITY COLLEGE STUDENT TRANSIT PASS PILOT PROGRAM - MOTION
49.1****ACTION: APPROVE ADOPTION OF UNIVERSAL COLLEGE STUDENT TRANSIT PASS
(U-PASS) PILOT PROGRAM****RECOMMENDATION**

Adopt the Universal College Student Transit Pass (U-Pass) Pilot Program.

ISSUE

As part of an ongoing effort to pursue strategies to increase student transit ridership, motion 49.1 requested an assessment of the feasibility of piloting a Universal Community College Student Transit Pass Program.

Currently, there are more than 1.4 million public college students in Los Angeles County, and only 14,000 (1%) are actively participating in Metro's reduced fare college pass programs, the College/Vocational (C/V) Pass and Institutional Transit Access Pass (I-TAP) programs. In addition, the C/V and I-TAP programs are only offered to full-time students who represent only 30% of public students in Los Angeles County, while the remaining 70% of students are considered part-time and are not eligible for these programs. Lastly, Metro's systemwide average fare per boarding (FPB) is \$0.75 while the I-TAP group rate pricing is only generating \$.29 per boarding. As a result, the I-TAP group rate pricing model is no longer revenue neutral to Metro, and combined, these programs are not reaching a large enough percentage of the student population.

Riding transit is an important life skill that should be learned at a young age. Many adults who have not previously ridden transit are intimidated by learning new routes and afraid of getting lost on an unfamiliar system. Broadening the use of transit at the college level will teach this skill in conjunction with other learning and create riders for life because users will understand the system.

DISCUSSION

Full-time undergraduate and graduate students in Los Angeles County are eligible for a reduced fare College/Vocational 30-day pass that is offered at a \$43 per month, a 57% discount from the regular Metro 30-day pass which is \$100 per month. In order to be eligible for the C/V pass, undergraduate students must be enrolled in a minimum of 12 units or 12 hours of in-classroom study per week for a minimum of 3 consecutive months. Graduate students must be enrolled in a minimum of 8 units of in-classroom study per week for a minimum of 3 consecutive months. Students can purchase the reduced fare TAP card directly from Metro and load it at Ticket Vending Machines (TVMs), customer centers, vendor outlets, or online.

In 2003 the Board adopted the I-TAP program. This program was designed to increase student ridership, while keeping the program revenue neutral for Metro. The I-TAP program allows schools to purchase passes directly from Metro on a semester or quarterly basis. Currently, there are only four (4) colleges participating in the I-TAP program:

- UCLA and USC are enrolled in the retail pricing model. The retail pricing model is the regular price of \$43/month or \$9.92/week multiplied by the number of weeks in a semester. (The weekly rate has been corrected to \$10.03 moving forward to reflect the 30-day rate divided by 30 multiplied by seven days.)
- Pasadena City College and Rio Hondo College are enrolled in the group rate pricing model. The group rate pricing model is based on the total number of full-time students multiplied by the group rate multiplied by the number of weeks in a semester.

Ridership data indicates that the I-TAP group pricing model resulted in a substantial increase in transit ridership over a five (5) year period (2010 - 2014):

- PCC increased ridership from 11% to 41% of their full-students
- Rio Hondo increased ridership from 7% to 44% of their full-time students

This resulted in an average ridership increase of 7% per year. Additional Metro bus services were added to support this growth in ridership. However, the current I-TAP Program at PCC and Rio Hondo is no longer revenue neutral for Metro. The average fare collected for these programs is \$0.29 per boarding versus the system average of \$0.75. Currently, there are approximately 7,000 active I-TAP users and 16,400 active College/Vocational TAP cards, but on average only 6,800 C/V Monthly Passes are being loaded.

In addition, Metro has not been utilizing existing and new technologies efficiently to improve these programs. Currently, the I-TAP and C/V paper applications are processed and uploaded manually. C/V applications became available online in September 2015 and represent approximately 5% of the total applications received since then. In March 2016, staff added a web link to the online application from the College Programs page on Metro.net and online applications rose to 9%. Metro has been processing an average of 2,100 paper applications per month and also handling the verification of each individual student's units, which has caused a wait time of 4-6 weeks for students to receive their C/V TAP cards from the time of application. However, many students are registering for their classes online and colleges have the ability to electronically verify their enrollment. Online

registration could be modified to allow students to add transit participation along with their enrollment. New TAP chip technology also exists which would allow a sticker with an embedded computer chip and an RFID antenna to be applied directly to the student ID cards, replacing the need for photo ID C/V TAP Cards. Just like existing TAP cards, these chips have the ability to be loaded remotely, reducing the need for a student to physically to go an office to reload or reactivate their cards once they have registered.

U-Pass Task Force Results

In November 2015, Metro Commute Services established two (2) U-Pass Task Force teams that included:

Internal Task Force (Metro):

- Office of Management and Budget (OMB)
- TAP Operation
- Office of Extraordinary Innovation

External Task Force:

- Los Angeles County colleges and universities including:
 - California Institute of Technology (CalTech)
 - California State University Dominguez Hills
 - California State University Long Beach (CSULB)
 - California State University Los Angeles (CSULA)
 - California State University Northridge (CSUN)
 - Cerritos Community College
 - Citrus College
 - LA Community College District (LACCD)
 - LAUSD Adult Vocational Programs (LAUSD)
 - Mount San Antonio College (Mt. SAC)
 - Pasadena City College (PCC)
 - Rio Hondo Community College
 - University of California at Los Angeles (UCLA)
 - University of Southern California (USC)
- Local municipal transit providers and organizations including:
 - Foothill Transit
 - Long Beach Transit
 - Los Angeles Department of Transportation (LADOT)
 - Move L.A.

In addition, an online survey was distributed to collect feedback from the colleges. The survey was anonymous to allow for the highest level of honest feedback and addressed issues such as satisfaction with existing Metro transit service, and cost and funding of student transit programs. Primary findings from the survey included:

- College transit programs are currently funded through pass sales, student fees, revenue from

-
- parking fines and fees, and associated student associations
- 73% are very satisfied or satisfied with the transit service at their campus
 - 82% say not having enough parking is an issue on their campus
 - 64% do not believe they have adequate funding for the program
 - 30% feel that not including part-time students is limiting participation, and
 - 60% are willing to co-market a Universal Pass program on their campus with Metro support

As a result of the feedback from the, Internal and External Task Force teams and survey responses, the overall recommendations are as follows:

- Make passes more affordable for students
- Make passes more accessible for part-time students
- Make program easy to understand and administer

U-Pass Pilot Program

Upon Board approval, Metro Commute Services will implement a two-year U-Pass pilot program beginning in Fall 2016. U-Pass Pilot Program will:

1. Target at least 10 new schools to participate in the program.
2. Reduce the minimum units required under the pilot to 8 units or more per quarter/semester to allow more part-time students to participate in pilot program.
3. Transition to a pay per boarding model:
 - a. Charge an estimated boarding fee of \$0.75 per boarding, which is the cash-boarding equivalent of the 30-day College/Vocational pass. Payment must be made by the school at the beginning of the term and the rate will be reassessed annually as part of the budget process.
 - b. For the introductory term, estimated boardings will be based on existing I-TAP or C/V ridership data. If the school does not have existing data, the initial student participation will be estimated at 10% of eligible students. Any overage paid by the school based on the estimated boardings for the introductory term will be credited toward the payment for Term 2.
 - c. For the second term and subsequent terms, estimated boardings will be adjusted to reflect the actual boardings from the previous term based on TAP data.
 - d. At the end of the second term and each subsequent term, actual boardings will be reconciled against the initial fee payment and a charge or credit will be issued to the school based on the difference, capped at \$43 per month (\$10.03 per week) per participant.
 - e. Schools may elect to cover the cost of the program through student fees, other funding, or by charging the students for participation. Fees collected from students may not exceed \$43/month or \$10.03/week, and the total amount collected may not exceed the total amount due to Metro.
 - f. Schools are encouraged to build U-Pass participation into their existing class registration process to allow for a seamless integration and the ability to charge the appropriate student fees, if any.

4. Schools will be responsible for collecting demographic data to assist in completion of the required Title VI analysis, for verifying enrollment eligibility for each quarter/semester, and for distributing or reactivating TAP stickers/cards for eligible students. Schools are encouraged to collect as much information as possible as part of online registration, which will also allow cards to be activated and loaded electronically by Metro.
5. Schools will report all issued TAP card/sticker numbers to Metro for tracking purposes and to facilitate replacements.
6. Schools are encouraged to partner with Metro for in-kind marketing materials and promotion of the U-Pass Program.
7. Establish goal of increasing student participation by 10% over existing C/V and I-TAP levels during the two year pilot program and use the data from the pilot program as a foundation for establishing an ongoing U-Pass program, which will ultimately replace both the I-TAP and the C/V programs. Performance measures to be assessed include:
 - a. Compare total U-Pass revenue and boardings to current I-TAP and C/V revenue and boardings and assess changes in fare revenues and ridership among the college/vocational student population
 - b. Assess changes in ridership on key lines near pilot schools
 - c. Compare the percentage of students who were issued passes on a term-by-term basis to assess changes in utilization of the U-Pass

DETERMINATION OF SAFETY IMPACT

This program does not affect the incidence of injuries or healthful conditions for patrons or employees. Therefore, approval of this request will have no impact on safety.

FINANCIAL IMPACT

As a pilot, this program will be managed within existing resources. Therefore, there will be no financial impact at this time.

Impact to Budget

As a pilot, this program will be managed within existing resources. Therefore, there will be no impact to budget at this time.

ALTERNATIVES CONSIDERED

Reduction of Units

Reducing the unit requirements for the U-Pass program was considered. With the existing 12-unit requirement for undergraduate students, there are approximately 14,000 active college transit program participants. This represents 3% of the total eligible public school students who meet the

requirement.

Decreasing the unit requirement for the U-Pass pilot program to 9 units (semester) or 8 units (quarter) would increase the potential pool of eligible participants by 17%, or approximately 250,000 public students. Based on the current 3% participation, this could result in about 7,500 new college/vocational riders. Decreasing the unit requirement for the U-Pass pilot program to 6 units would increase the potential pool of eligible participants by 35%, or approximately 536,000 public students. Based on the current 3% participation, this could result in about 16,000 new college/vocational riders.

For both cases, increasing the potential pool of eligible participants will likely result in revenue loss for Metro, with the possibility of recouping the loss through a potential increase in new riders. However, the potential revenue impact will depend on how many of the new college/vocational riders were full fare transit riders (negative impact to revenue) versus how many are new transit riders (positive impact to revenue).

Because the financial impact of the unit reduction will not be known until the overall fare revenue changes for the pilot program and the agency can be assessed, staff recommends starting the pilot program with an 8-unit minimum requirement with a commitment to review the revenue impact after six months and consider lowering the requirement to 6 units based on the assessment. The 12-unit requirement for current monthly C/V passes will remain intact.

The College/Vocational Pass requires graduate students to be enrolled in 8 or more units. Under the U-Pass Pilot Program, staff is recommending reducing the units required for graduate students from 8 units to 6 units. The 8-unit requirement for graduate students utilizing monthly C/V passes will remain intact.

Continuation of I-TAP and C/V Programs

Due to the lack of widespread usage, difficulty of administration, and the loss of revenue, staff does not recommend continuing the I-TAP program during the U-Pass Pilot Program. All current I-TAP schools will be converted to U-Pass. However, Metro will continue to offer the regular monthly College/Vocational Pass for students at schools not participating in the pilot program.

NEXT STEPS

Upon approval of this pilot program, Metro will:

1. Communicate details of U-Pass Pilot Program with all 77 schools in L.A. County and target 10 or more schools to participate in the program.
2. During initial registration period, schools will collect required Title VI data from participating students. Title VI evaluation will be conducted and a findings report will be brought back to the Board of Directors for approval prior to the end of the sixth month of the pilot program.
3. During the pilot program, Metro will continue to seek additional funding through Greenhouse

Gas Reduction Fund/Low Carbon Transit Operations Program (LCTOP) revenue Cap and Trade, the South Coast Air Quality Management District's Mobile Source Air Pollution Reduction Review Committee (MSRC), or other sources to further reduce the cost of the program to the schools and will work with schools to identify other sources of funding such as parking fees and/or fines, student association fees, and/or activity fees and/or referendums and as a means of subsidizing the program.

4. During the pilot program, Metro will continue to partner with schools to address transit service and service alignment issues.

ATTACHMENTS

Attachment A - Motion 49.1 Community College Student Transit Pass Pilot Program

Attachment B - Report 49 on Community College Student Transit Pass Pilot Program in response to Motion 49.1

Prepared by: Devon Deming, Dir. of Metro Commute Services, (213) 922-7957
Jocelyn Feliciano, Communications Manager, (213) 922-3895
Glen Becerra, DEO Communications, (213) 922-5661

Reviewed by: Pauletta Tonilas, Chief Communications Officer, (213) 922-3777

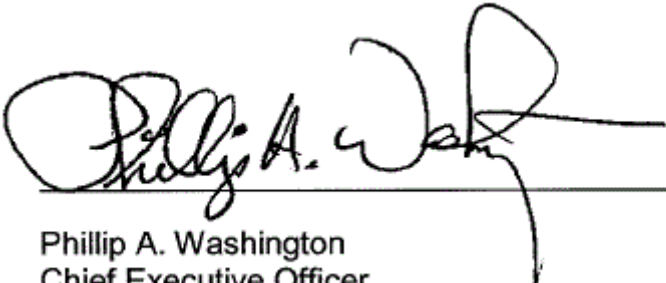

Phillip A. Washington
Chief Executive Officer



Expanding Metro's U-Pass Program to K-12

For Homeless Student Support Services

Executive Management Committee, File # 2019-0879

Metro Commute Services:

Devon Deming, *Director of Commute Services*

Direct: 213.922.9757

Jocelyn Feliciano, *Communications Manager*

Direct: 213.922.3875



Metro

Regional U-Pass & K-12 U-Pass Pricing

1. Existing U-Pass Pricing is \$0.75 per boarding, capped at \$43 per month, which is the current College/Vocational Reduced Fare Monthly rate
2. The pricing above includes regional boardings on 9 additional transit agencies, and staff is recommending continuing the Regional U-Pass Program for College/Vocational Schools at the current pricing.
3. Staff is recommending a approval of a new K-12 U-Pass rate for homeless student services programs at \$0.75 per boarding capped at \$24 per month, which is the current K-12 Reduced Fare monthly rate
4. If the cost to reimburse the 9 additional transit agencies exceeds \$24 per month, staff is recommending that the institution be invoiced for the overage with the monthly cost capped at the monthly K-12 rate of agencies used by the school's students during that semester.

K-12 U-Pass Pricing

Other Transit Agencies' Monthly K-12 Reduced Fare	
Big Blue Bus	\$30 Youth 30-Day Pass
Foothill Transit	\$36 31-Day Pass
Glendale Beeline	\$22 31-Day Pass
Long Beach Transit	\$40 Monthly Student Pass
Montebello Bus	\$30 Monthly Student Pass
Torrance Transit	\$30 Monthly Student Pass



Board Report

File #: 2020-0045, **File Type:** Agreement

Agenda Number: 45.

**EXECUTIVE MANAGEMENT COMMITTEE
JANUARY 16, 2020**

SUBJECT: BRIDGE HOUSING AT VAN NUYS STATION

ACTION: APPROVE RECOMMENDATIONS

RECOMMENDATION

Direct the Chief Executive Officer (CEO) to:

- A. Enter into a no-fee lease agreement with the City of Los Angeles (COLA) with a term ending August 15, 2023 for temporary bridge housing on a portion of the Van Nuys Orange Line Station parking lot;
- B. Re-inventory Metro-owned properties to identify other opportunities for the City of Los Angeles's A Bridge Home Program (ABH) facilities and report back to the March 2020 Executive Management Committee;
- C. Conclude the project is statutorily exempt from CEQA pursuant to Public Resources Code Sections 21080.27 and 21080, Subdivision (b)(4), and CEQA Guidelines Section 15269, Subdivision (c); and
- D. Authorize Metro staff to file a Notice of Exemption with the County Clerk.

ISSUE

In April 2018, the Los Angeles Mayor and City Council declared a shelter crisis in the City of Los Angeles. According to the 2019 Greater Los Angeles Homeless Point-in-Time Count released by Los Angeles Homeless Services Authority (LAHSA), 36,300 homeless individuals reside in the City of Los Angeles, 27,221 of who are unsheltered.

In May 2018, Metro prepared an inventory of Metro-owned property that may be suitable for temporary homeless housing. Among other properties, Metro's assessment identified a portion of the Metro parking lot at the Van Nuys Orange Line Station on 14333 Aetna Street (Site) as viable.

Board action is required to authorize the CEO to enter into a no-fee lease with the City of Los Angeles for an ABH facility on the Site.

BACKGROUND

A Bridge Home

To respond to the homeless crisis and the immediate need for shelter, the Mayor and Los Angeles City Council allocated \$39 million in their Fiscal Year 2018-19 and 2019-20 budgets to establish temporary crisis and bridge housing facilities, with the goal of adding 750 to 1,500 new beds citywide. In addition, \$54 million has been committed within the City of Los Angeles' Homeless Emergency Aid Program allocation from the State of California to construct and operate ABH facilities. The Mayor's deadline to construct, complete, and open all ABH sites is June 2020. Each site will operate for a minimum of three years to support the development of supportive permanent housing for ABH residents.

On May 29, 2019 a Los Angeles City Council Motion (Council File 19-0563) instructed City staff to evaluate and report on the feasibility of using a portion of the Van Nuys Orange Line Station parking lot for establishing an ABH facility. City agencies determined that the Site is suitable for such purpose. The Site will include bridge housing facilities including storage for residents, personal hygiene and laundry facilities, supportive and community engagement services, and 24-hour security. LAHSA will identify a service provider to operate the facility.

As per the terms of the proposed lease, COLA will return the Site to Metro, restored to its original condition, by August 15, 2023.

Van Nuys Orange Line Station Parking Lot

The Van Nuys parking location is large, flat, and currently underutilized for parking. A portion of the parking lot is currently leased by an automotive dealer. The dealer can maintain its current lease area and will share a driveway with ABH.

DISCUSSION

Findings

Metro Capital Projects

Metro Program Management has confirmed that the Site will not be required for the East San Fernando Valley Transit Corridor (ESFVTC) or the Sepulveda Transit Corridor projects prior to August 15, 2023. See below for discussion on the Metro Orange Line Bus Rapid Transit Improvements Project (MOL Improvements).

Operations

The Site is adjacent to the MOL dedicated busway, as well as the MOL Van Nuys station. Standard protections for Metro operating right-of-way are currently in place and will continue to be maintained. As part of the lease terms, COLA will provide site security and maintenance plans for Metro review and approval no later than 60 days prior to commencement of operations.

Parking

The ABH facility is expected to occupy approximately 100 parking spaces. Currently, there is sufficient space to accommodate transit riders, the automotive dealership and the ABH facility.

The North Hollywood Joint Development (NoHo JD) project is scheduled to break ground in 2022. If a determination is made to reduce parking at North Hollywood during the NoHo JD construction, some parking may be diverted to the Van Nuys station. However, with revisions to the automotive dealership lease, Metro staff believes there is sufficient parking space at Van Nuys to absorb potential NoHo overflow and accommodate MOL Improvements.

To accommodate the ABH facility, the parking lot will require minor traffic flow modifications and removal of a few parking spaces. That can be accomplished by Metro restriping a portion of the parking lot with the cost estimated not to exceed \$30,000.

Joint Development

The Site has been identified as a potential joint development location, but any joint development would not take place until after the design is complete for adjacent transportation projects such as the ESFVTC and the MOL Improvement's projects. No new development would break ground prior to August 15, 2023.

ABH California Environmental Quality Act (CEQA) Exemption

Metro staff have reviewed and considered the November 19, 2019 City of Los Angeles Public Works: Engineering Staff Report for the "Crisis and Bridge Housing Facility at 14333 Aetna (19-0563) CEQA Notice of Exemption (NOE)" ("Staff Report") and associated documents. Metro adopts the determinations made by the City of Los Angeles City Council when it approved the project at its November 27, 2019 meeting, in reliance on the Staff Report and other documents contained on the City's website related to the project.

The project is statutorily exempt from CEQA pursuant to Public Resources Code section 21080.27. The no-fee lease agreement is exempt from CEQA pursuant to Public Resources Code Section 21080.27, Subdivisions (a)(1)(C) and (b)(2).

The project is also statutorily exempt from CEQA pursuant to Public Resources Code Section 21080, Subdivision (b)(4), and CEQA Guidelines Section 15269, Subdivision (c).

Considerations

MOL Improvements

The MOL will be completed using various construction contracts. The contract for the Van Nuys section is planned to include a grade separation (GS) with an aerial station at Van Nuys Blvd, and approach ramps on the west and east end of the station, together with the use of a laydown area located to the south of the existing MOL alignment.

The approach ramps at each end of the aerial structure are planned to be built using a Mechanically Stabilized Earth (MSE) wall system. The system requires constructing MSE wall panels on both sides of each approach ramp and importing and compacting a large quantity of fill material between the walls. The Site is adjacent to the east MSE wall as shown on Attachment A and will be needed for the MOL Improvements project.

From fall 2022 to spring 2025, the GS construction will require:

- Relocating the busway and Van Nuys station to an adjacent street;
- Closing the existing busway, station and a portion of the parking lot (including the Site) in the diversion area;
- Setting up construction staging and laydown area at the Van Nuys parking lot; and
- Constructing aerial structure/station and MSE wall system.

Leasing the Site for an ABH facility will impact certain construction work on Metro's MOL Improvements project. The bid documents will dictate that the contractor may not utilize the Site until after August 15, 2023. Dictating means and methods of the design-build contract may result in higher Metro costs and risks which cannot be quantified at this time. The proposed lease terms include COLA indemnifying Metro against all liabilities and damages if the Site isn't restored to its pre-lease condition and vacated by August 15, 2023. The proposed lease terms also include that COLA may holdover on a month-to-month basis, subject to site availability, and if no additional costs will be incurred by Metro as a result of the holdover.

The GS is located in an industrial/commercial-zoned area and was determined to be statutorily exempt under CEQA as such. The MOL Improvements contractor will have the right to construct around and adjacent to the Site and will provide any required construction mitigations for industrial/commercial uses. The proposed lease terms will include that COLA defend, indemnify and hold Metro harmless for any costs or damages Metro incurs as a result of COLA's use of the Site for residential purposes. Likewise, the lease terms will include language specifying that the City is not liable for damages that are not the result of its use and occupancy of the site.

Although leasing the Site for an ABH facility will result in potential risk to budget and schedule, Program Management believes that the MOL Improvements can still be completed by the Measure M targeted date of 2025.

Homelessness

The ABH program will deploy teams of outreach workers to engage homeless who live around the ABH sites to ensure that people moving into ABH are already residents of the neighborhood. ABH team will consult with Metro's homeless outreach team for assistance in determining eligible participants for the program. As the new ABH site opens its doors, COLA homeless outreach teams will work to restore spaces that were previously encampment sites into open and clear public spaces. This effort will benefit Metro customers as it will reduce the encampment sites around the Van Nuys station.

Equity Platform

Use of Metro's property for ABH facilities meets the Equity Platform Pillar II - Listen and Learn by actively engaging members of the homeless community, as well as Pillar III - Focus and Deliver, to provide needed solutions for the homeless.

DETERMINATION OF SAFETY IMPACT

There are potential safety issues with having a residential development close to a dedicated busway,

however, many Metro stations and rights of way are adjacent to residential improvements. Metro staff will work with COLA to ensure proper fencing and segregation between operational areas and the ABH facility.

FINANCIAL IMPACT

Adoption of the COLA lease will require parking operations to restripe the remaining existing lot, estimated at \$30,000.

Depending on the impact to parking for the NoHo JD project, there may be some reduction in lease revenue from revising the lease with the automotive dealership in a way that will allow the ABH facility to stay through August 15, 2023.

The financial impact to the MOL Improvements construction bids is unknown. Keeping bid requirements to a minimum results in the best financial outcome for construction contracts. It is not possible to determine the impact to bids of incorporating the condition not to use the Site until August 15, 2023.

Impact to Budget

The minor restriping of the parking lot can be done under existing budget cost center 3046, project 308001.

IMPLEMENTATION OF STRATEGIC PLAN GOALS

Recommendation supports Strategic Plan goal #3 of enhancing communities and lives by providing shelter and supportive services for homeless.

ALTERNATIVES CONSIDERED

The Board could choose not to authorize the CEO to execute the lease. This is not recommended as homelessness continue to be a challenging issue that requires housing and supportive services.

NEXT STEPS

Upon approval, the CEO will execute the no-cost lease, and staff will review Metro's real estate holdings to determine if any additional properties can be utilized for ABH facilities and will file a Notice of Exemption with the County Clerk

ATTACHMENTS

Attachment A - MOL Improvements

Prepared by: Holly Rockwell, SEO - Real Estate, Transit Oriented Communities and Transportation Demand, Countywide Planning & Development
Bryan Pennington, Deputy Chief Program Management Officer, Program Management

Hitesh Patel, DEO, Project Management, Program Management
Brad Owen, DEO, Project Management, Program Management

Reviewed by: James de la Loza, Chief Planning Officer, (213) 922-2920
Richard Clarke, Chief Program Management Officer, (213) 922-7557

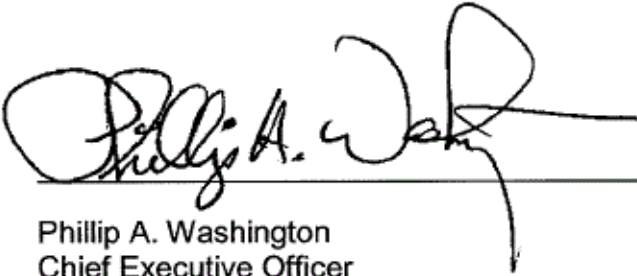



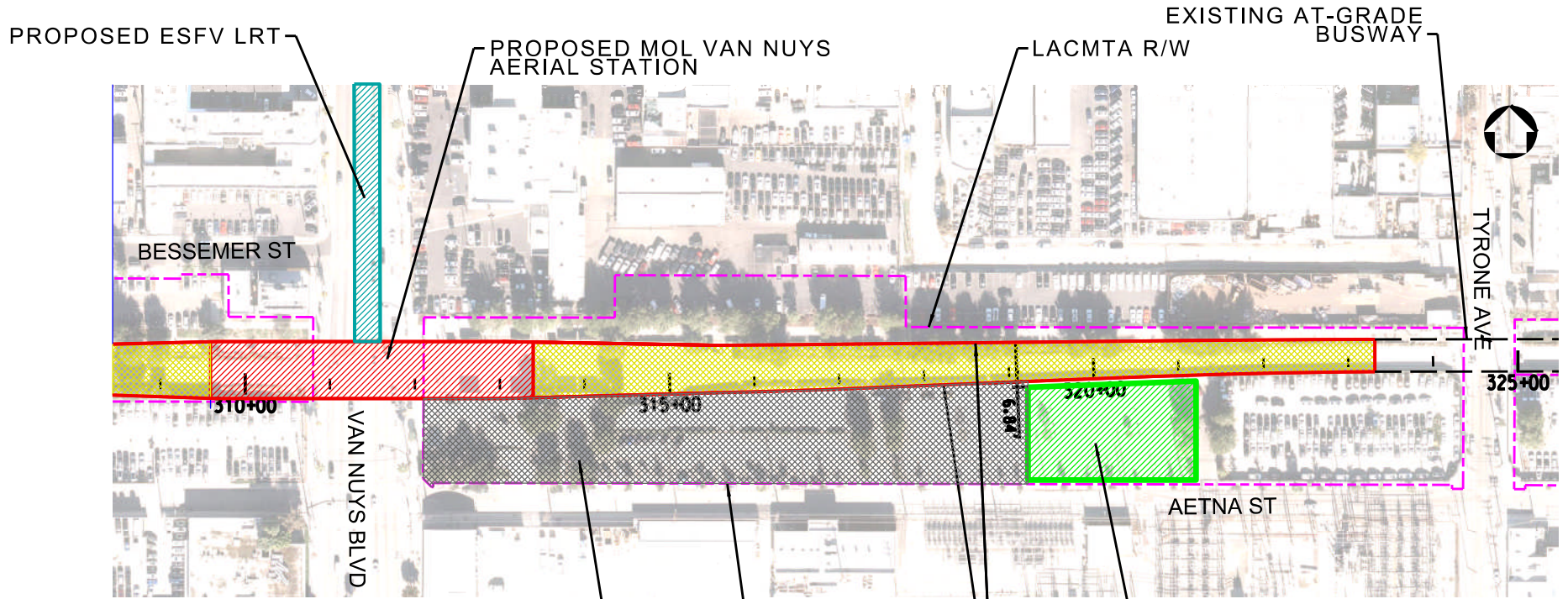

Phillip A. Washington
Chief Executive Officer

MOL BRT IMPROVEMENTS - VAN NUYS GRADE SEPARATION ADJACENT TO PROPOSED BRIDGE HOME



LEGEND:

-  MOL AERIAL STRUCTURE / STATION
-  APPROACH RAMP (MSE WALL SYSTEM)
-  PROPOSED BRIDGE HOME SITE (JAN 2020 - AUG 15, 2023)
-  LAYDOWN / STAGING / STORAGE AREA DURING MOL CONSTRUCTION (FALL 2022 - JUNE 2025)
-  ESFV LRT (CONNECTION WITH MOL UNDER REVIEW)



Board Report

File #: 2019-0833, File Type: Contract

Agenda Number: 12.

REVISED

PLANNING & PROGRAMMING COMMITTEE

JANUARY 15, 2020

EXECUTIVE MANAGEMENT COMMITTEE

JANUARY 16, 2020

SUBJECT: MOBILITY ON DEMAND PILOT PROJECT

ACTION: EXECUTE CONTRACT OPTION

RECOMMENDATION

AUTHORIZE the Chief Executive Officer to execute a Modification to Contract No. PS121778000 to exercise a six-month extension to the existing contract with NoMad Transit LLC, to continue to operate the Mobility on Demand (“MOD”) pilot project with enhanced service design for additional research at an increase in contract value not to exceed ~~\$1,530,332~~ \$2,180,332, increasing the contract value from \$2,506,410 to ~~\$4,036,742~~ \$4,686,742, and, at the discretion of the Chief Executive Officer, add an additional six months of service for a not to exceed amount of ~~\$2,097,293~~ \$2,747,293, increasing the contract from ~~\$4,036,742~~ \$4,686,742 to up to ~~\$6,134,035~~ \$7,434,035, with no further options to extend.

ISSUE

In 2018, Metro partnered with NoMad Transit LLC to provide a pilot on-demand, shared-ride service that launched on January 28, 2019 with a duration of one year, and an option to extend for a second year. This pilot is providing research insights to inform MicroTransit, expanding the availability of ride-hailing services to users who would not otherwise have access, promoting sustainability and congestion reduction through shared rides, and growing the reach of Metro fixed-route services. The Board has received quarterly reports regarding the service operations over the 2019 calendar year.

In October 2018, the Board authorized the execution of a 12-month contract in an amount not-to-

exceed \$2,506,410, with the option to renew for an additional year at a baseline amount of \$2,506,410, to be negotiated based on the initial 12-month pilot period for a total amount of \$5,012,820.

Year one of the contract will close having spent \$1,939,448 of the \$2,506,410 contract authority, leaving a balance of \$566,962. Staff recommends (a) applying the first-year remaining balance of \$566,962 to the first six months of the second contract year, (b) executing a six-month extension in an amount not to exceed ~~\$1,530,332~~ \$2,180,332 (c) delegating authority to the Chief Executive Officer to execute a subsequent six-month extension in an amount not to exceed ~~\$2,097,293~~ \$2,747,293 for a total not to exceed amount of ~~\$3,627,625~~ \$4,927,625. Staff has applied for grant funding which may become available early in 2020 that could be applied to the contract or to the MicroTransit program.

BACKGROUND

As reported to the Board in the Third Quarter Report (Attachment A), ridership and efficiency of the service have been steadily increasing and the service now provides nearly 2500 rides per week at a rate of approximately 2.6 rides per driver hour.

Grantee partners in the Seattle area are serving over 7000 rides per week at a rate of over 5 rides per driver hour. The higher ridership and efficiency numbers are attributed to longer operating hours that include evenings and weekends, more robust outreach, and shorter trip lengths. The second year of the Los Angeles pilot aims to test if longer operating hours and additional outreach efforts can increase adoption and efficiency in line with what is being seen in Seattle.

Subsidy

The pilot has created an excellent service that extends the reach of Metro fixed route transit. Such a service is not expected to be price competitive with Metro's most efficient bus and rail offerings but can offer a tool to maintain and increase ridership as competitors come into the marketplace. Bearing that in mind, staff has calculated an average trip subsidy and attempted to compare it with other modes.

At the close of Q3, MOD ride subsidies were averaging about \$13 per ride, and 2.5 miles in length. By comparison, an infrequent bus route can cost up to \$21 per ride and only provide service nearly once an hour. Access Services trips have a subsidy of \$39 per ride, regardless of length. They also require booking a day in advance and pick up times are subject to negotiation depending on vehicle availability. Access Services trips average ten miles in length (much longer than MOD trips), but Access Services pays the same price for rides of any distance, and 35% of the trips are less than five miles. MOD ride subsidies and customer service are therefore an improvement over Access Services rides. Metro also subsidizes park and ride parking and Metro Bike Share at rates comparable to MOD.

Mode	Avg. trip length	Max wait time	On-demand?	Subsidy per ride	Convenience
Mobility on Demand	2.5 miles	20 min	Yes	\$13	High
Access Services*	10 miles	N/A	24 hrs in advance	\$39	Medium
Infrequent bus**	2.36 miles	60 min	No	\$21	Low
Park & Ride	N/A	0 min	Yes	\$12***	High
Bike Share	1 mile	0 min	Yes	\$8	Medium

*Shorter trips have the same subsidy as Access Services pays its vendors per trip

**Metro Bus 607 (with current lowest route performing index of Metro Bus lines)

***In addition, park and ride lots are a barrier to transit oriented development and pedestrian access

Research Findings

Survey data suggests that the average first last mile travel time has been cut in half for Metro riders on NoMad compared to their previous mode. Fifty percent of NoMad rides are less than nine minutes in length and 95% are less than 22 minutes. Data also suggests that around 9% of users were new to transit altogether, 46% of trips were a first last mile trip shifted from private vehicles or private ride hailing, 33% of trips from buses, and 14% from walking or rolling. Additional research findings are included in Attachment B.

Requests for wheelchair accessible vehicles continue to account for about 1% of total rides. By comparison, 0.5% of Metro Bus trips are made by people in wheelchairs. NoMad call center trips continue to account for about 1% of the total trips booked, while 48% of Metro Bus riders and 27% of Metro Rail riders do not have smart phones.

Initial research findings have been collected through surveys administered by the independent evaluator, though results are not statistically significant. Preliminary data suggest that the median income of the users is around \$50,000 and the racial makeup is 35% white, 30% Latinx, 23% Asian, 6% Black, 1% American Indian, and 6% Other. The survey respondents were 52% male, 45% female and 3% non-binary. Additional research will be analyzed and used to determine if the second six months of the contract will be executed.

DISCUSSION

Due to the success of the first year of the pilot, and the potential for additional critical research findings and increased adoption in a second year, staff is recommending an additional six-months to a year of the pilot with updates to the service design to optimize customer experience and increase adoption by target riders. Service in the second year would include the following modifications:

- In order to comply with Assembly Bill 5 (AB5), Independent Driver Partners will now be employees, receive compensation for the mileage they travel in their personal cars, and may elect to receive health care or a benefits stipend.
- Marketing services will be enhanced to strengthen grassroots awareness and increase adoption by riders who are low income, do not have smart phones, or have disabilities.
- Service days and hours will be extended to include evenings and weekends (currently service is only operational from 6AM to 8PM on weekdays). Exact hours will be determined based on utilization, customer feedback and budget considerations.
- ~~In order to accommodate the increased costs associated with the employee model and extended service hours, g~~ Geographic coverage will continue in North Hollywood, ~~be focused on the El Monte and Compton service areas, as shown on maps included in Attachment C.~~
- Service design will remain subject to change per mutual agreement based on iterative operational feedback.

Provided that the contractor will be converting their independent contractor driver partners to operator employees in the new year to be compliant with AB5 the increased price of a driver hour has been included in the modification total.

Outreach and marketing for the upcoming year will be more robust and community focused in order to increase adoption by target populations. Outreach will include opportunities for engagement and feedback to help Metro understand the needs of these communities from a new mobility standpoint.

DETERMINATION OF SAFETY IMPACT

The MOD pilot project will not have any adverse safety impacts on Metro employees or patrons. It may have a positive safety benefit by reducing personal driving trips and increasing trips made with professional drivers.

FINANCIAL IMPACT

There will be no financial impact to the FY2020 budget as the additional funds would not be needed until FY2021. The funds required for FY2021 would be budgeted through the FY2021 budget process. Staff has applied for additional grant funding for the second year of service.

Impact to Budget

The current year funding for this action will come from General Fund revenues and Grant revenues. These funds are eligible for Bus and Rail Operating projects. No other funds were considered

because these funds are programed for this use.

IMPLEMENTATION OF STRATEGIC PLAN GOALS

Staff's recommendation supports the following goals form Metro's Strategic Plan:

Goal 1: Provide high-quality mobility options that enable people to spend less time traveling.

The project increases access to Metro fixed route services with a platform that provides excellent customer experience and shortens travel times for riders who must transfer.

Goal 2: Deliver outstanding trip experiences for all users of the transportation system.

The project provides seamless journeys and expands access to on-demand transportation to riders who use wheelchairs, do not have smart phones, or do not have the financial means to use private services.

Equity Platform Framework

The project is addressing inequity in new mobility options by providing access to people who would not otherwise be able to use on-demand rideshare platforms like Uber and Lyft. The project allows people without smartphones or bank account, and people who use wheelchairs to experience the benefits of on-demand mobility and seamless access to Metro fixed route offerings. MOD is offered in low income areas to encourage use by low income riders and will be marketed in this way as well.

ALTERNATIVES CONSIDERED

The Board may decide not to authorize the CEO to exercise the contract options with NoMad Transit. This alternative is not recommended as it does not allow Metro to explore additional research inquiries or continue to provide high quality trip experiences as identified in Metro Vision 2028.

NEXT STEPS

Upon Board approval, Metro staff will execute the Modification to Contract No. PS121778000 to extend the contract with NoMad Transit LLC for the MOD pilot, as originally contemplated in the October 2018 Board Report. Service would continue for an additional six months. During those six months, the Chief Executive Officer will determine if the service should continue for an additional six months, terminating no later than the end of January 2021. There are no additional contract options to extend after this date. Updates on the pilot operations will continue to be provided to the Board.

ATTACHMENTS

Attachment A - Third Quarter Report

Attachment B - Preliminary Research Findings

Attachment C - Service Areas Map

Attachment D - Procurement Summary

Attachment E - Contract Modification Log

Prepared by: Marie Sullivan, Manager, Transportation Planning, (213) 922-5667

Reviewed by: Joshua Schank, Chief Innovation Officer, (213) 418-3345

Debra Avila, Chief Vendor/Contract Management Officer, (213) 418-3051

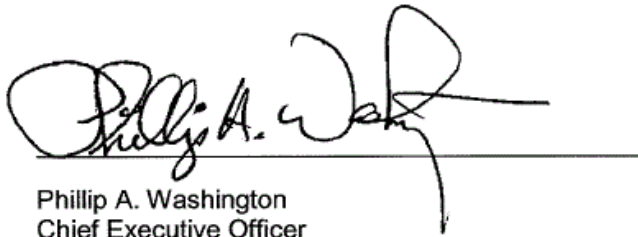

Phillip A. Washington
Chief Executive Officer



Metro

Los Angeles County
Metropolitan Transportation Authority

One Gateway Plaza
Los Angeles, CA 90012-2952

213.922.2000 Tel
metro.net

NOVEMBER 25, 2019

TO: BOARD OF DIRECTORS

THROUGH: PHILLIP A. WASHINGTON *PAW*
CHIEF EXECUTIVE OFFICER

FROM: JOSHUA L. SCHANK *JLS*
CHIEF INNOVATION OFFICER

SUBJECT: MOBILITY ON DEMAND: THIRD QUARTER REPORT AND
ASSEMBLY BILL 5 COMPLIANCE

Metro's Mobility on Demand pilot has completed nine months of service and more than 45,000 rides. This on-demand, shared-ride pilot is delivered through a partnership with ride share company Via. It makes ride-hailing services available to users who would not otherwise have access, promotes sustainability and congestion reduction through shared rides, and expands the reach of Metro fixed-route services. Additional information about the service can be found in Attachment A.

The pilot has now been operational for nine months; the third quarter (Q3) concluded October 25, 2019. Since the second quarter report was delivered to the Board in September, ridership has continued to grow far beyond the original target Key Performance Indicators (KPIs). The utilization per service hour has also continued to rise, exceeding the target 2.5 rides per driver hour near the close of the third quarter.

A new California Law (AB 5) changes the test that determines whether drivers and other workers are employees and goes into effect on January 1, 2020. Staff is amending the contract with Via to require drivers to be employees. Staff is pursuing a potential second year of this short-term research pilot, which would adjust the service design based on findings from the first year.

PERFORMANCE

Ridership

Since service launched in January, the number of rides has increased from 160 in the first week of service to 2,336 per week at the close of the third quarter, a nearly 15-fold increase since the beginning of the pilot. The steadily increasing ridership is a likely indicator of customer satisfaction and efficacy of the service.

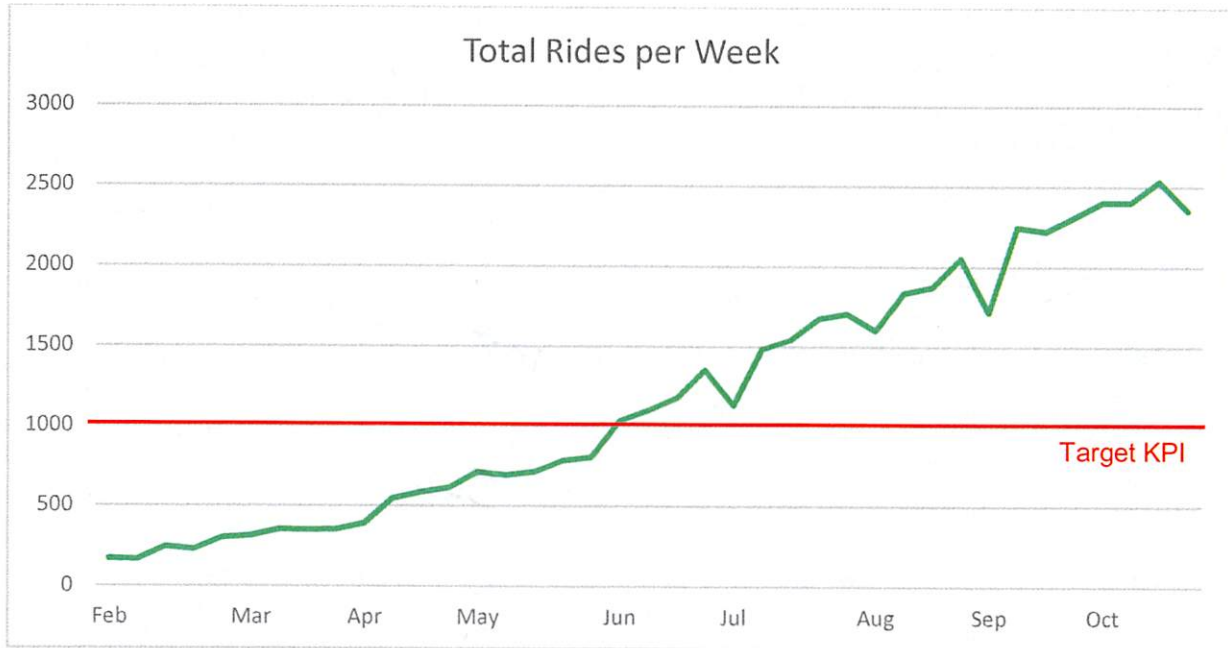

The El Monte service area continues to be the most popular zone. The Artesia/Compton zone has lower ridership, likely due to the New Blue service closures. Rail service for the southern segment of the A Line (Blue) was suspended from January 2019 to June 2019. Service for the northern segment of the A Line was suspended in June 2019 and reopened on November 2, 2019.

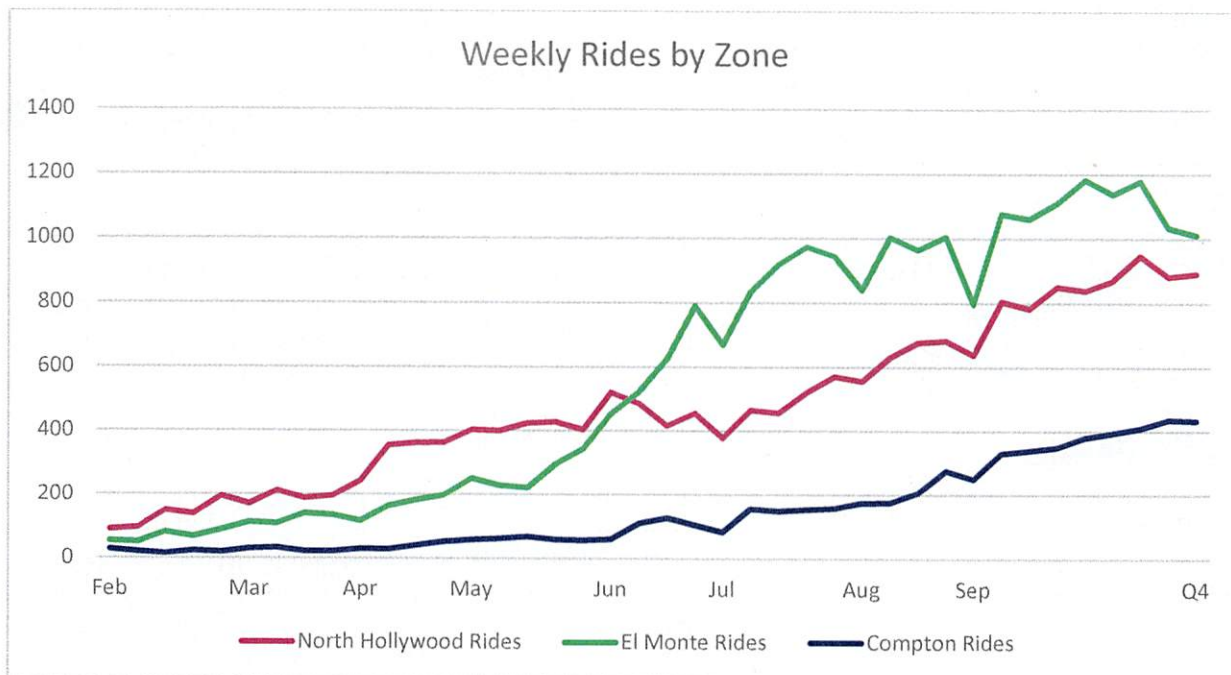

Rides per Driver Hour

The ratio of rides to driver hours has vastly improved since the launch of the service.

Utilization was at 0.1 rides to driver hours in Week 1 and by Week 12, Via had 1.2 rides to driver hours, a tenfold increase over the quarter. The ratio continued to climb over the second quarter reaching nearly two rides per driver hour by the end of the second quarter. The close of the third quarter saw a ratio of 2.7 rides per driver hour, exceeding the performance goal of 2.5.

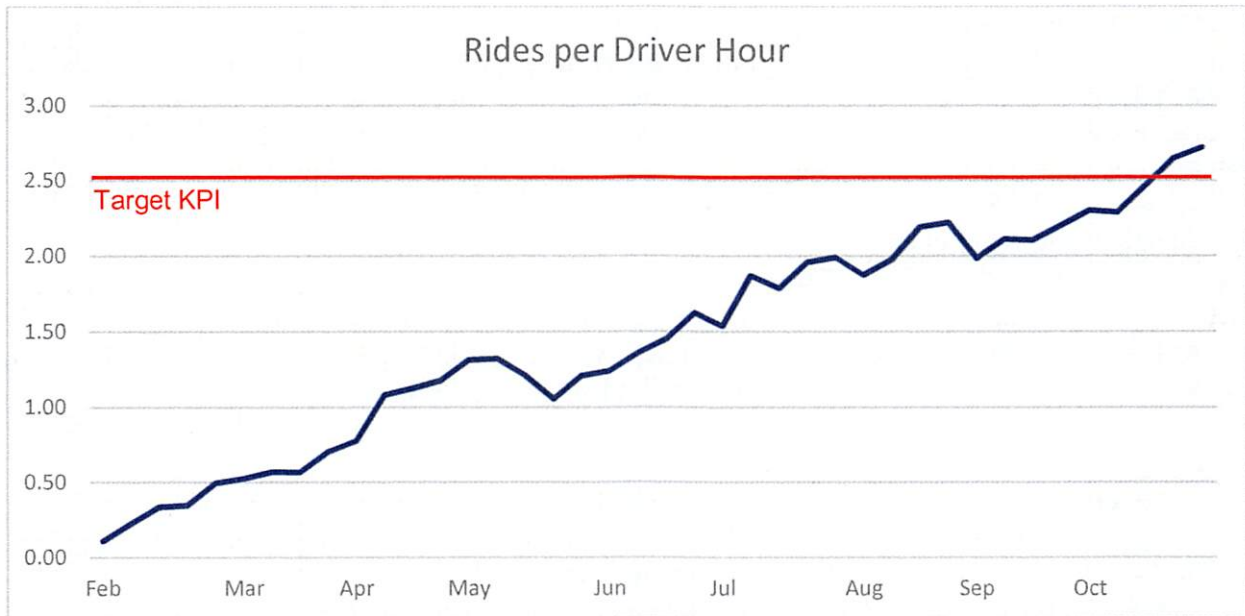

Key Performance Indicators

As detailed in the chart below, three out of the four target KPIs were met and exceeded in Q3.

KPI	Target	Q1 end	Q2 end	Q3 end	Target Met?
Avg wait time	10 min	7 min	9 min	11.5 min	No
Avg Customer Rating	4.5	4.9	4.9	4.8	Yes
Rides/ driver hour	2.5	1.12	1.8	2.7	Yes
Weekly rides	1000	585	1675	2336	Yes

In the final weeks of Q3, the rides/driver hour goal was met, but the average customer wait time slipped over the 10-minute goal. This 10-minute goal has been met for a vast majority of the service operation. This highlights the tradeoff between service quality and efficiency, and Via will continue to adjust the service supply to balance both.

Customer Payment and Fares

The free transfer fare has continued through Q3 and will remain in effect until the completion of the first year of service. This means that while customers are not paying Via for the service, but all Via customers are paying to ride Metro, the net fare remains \$1.75.

Subsidy

At the close of Q3, ride subsidies were averaging about \$13 per ride, and 2.5 miles in length. By comparison, an infrequent bus route can cost up to \$21 per ride for a ride of similar length and only provide service about once an hour. Access Services trips have a subsidy of \$39 regardless of length, require booking a day in advance, and pick up times are subject to negotiation depending on vehicle availability. While Access Services trips average ten miles in length (much longer than MOD trips), Access Services pays their contractors same price for rides of any distance, and 35% of the trips are less than five miles.

Reaching hard to reach populations

Requests for wheelchair accessible vehicles continue to account for about 1% of total rides. By comparison, 0.5% of Metro Bus trips are made by people in wheelchairs. Via call center trips continue to account for about 1% of the total trips while 48% of Metro Bus riders and 27% of Metro Rail riders do not have smart phones.

Research

The Eno Center for Transportation, as well as University of California Los Angeles, University of Oregon, and University of Washington are analyzing both qualitative and quantitative data from the pilot that will inform a final project report. That data will help to determine whom the pilot has been able to serve, and if the benefits have been in line with the project goals.

Findings to inform MicroTransit

Findings from the partnership with Via are being shared with the MicroTransit team to provide insights in preparation for the launch of MicroTransit in 2020.

Lessons from Seattle

The Via service in the Seattle area has seen even higher adoption and efficiency with over 7,000 rides per week and over five rides per driver hour. The Seattle area service differs in that the service additionally runs during evenings and weekends, the rides are provided in a dedicated, branded fleet of consistent vehicles, transit patrons can tap their transit passes on a card reader inside the vehicles, and the service zones are contiguous for more efficient operation. Metro staff is exploring the possibility of implementing several of these features in a potential second year of the Via partnership.

NEXT STEPS

Assembly Bill 5 Compliance

The Governor signed AB5 in September 2019, which will require many workers classified as independent contractors to become company employees. Metro asked Via to change the driver employment model under the contract from independent contractors to employees. Via has agreed to work with Metro to change the model on

January 1, 2020. Metro is working with Via to ensure that any updates to the contract documents that need to be made are completed in advance of January 1, 2020.

Contract Option

The contract for the pilot with Via has a base term of one year, with an option to extend to a second year. Metro is now negotiating a potential second year of the pilot contract with Via. Assuming consensus is reached on a second year, staff will bring a recommendation to the Board for a second year of service in early 2020. The design of a second year of service will take into account the findings from the first year of the service and will seek to improve customer experience and to increase marketing and outreach efforts to low-income patrons and patrons without smart phones.

If the Board approves a negotiated second year of the pilot, the additional research learnings would continue to inform the service design for MicroTransit throughout the potential second year. The pilot would not extend beyond a second year as the contract with options will expire January 28, 2021.

Attachment A – Background

Metro's Mobility on Demand (MOD) pilot is funded in part by a Federal Transit Administration (FTA) MOD Sandbox Demonstration Grant. The goals of this pilot are to test the viability of using on-demand technology to connect people to Metro's transit system (current and new customers) and to open access to transportation network companies (TNCs) to more people by making the service more accessible.

Metro launched a service partnership with Via on Monday, January 28, 2019 in three zones around the Metro North Hollywood, El Monte, and Artesia Stations. Under this pilot, Via provides first and last mile rides to or from transit stations. The service operates Monday through Friday from 6am to 8pm. Zones were set with a radius of one to 1.5 miles at service launch. Thereafter in April of 2019, the zones were expanded to a radius of two to 2.5 miles to capture additional potential riders and improve mobility for the surrounding neighborhoods.

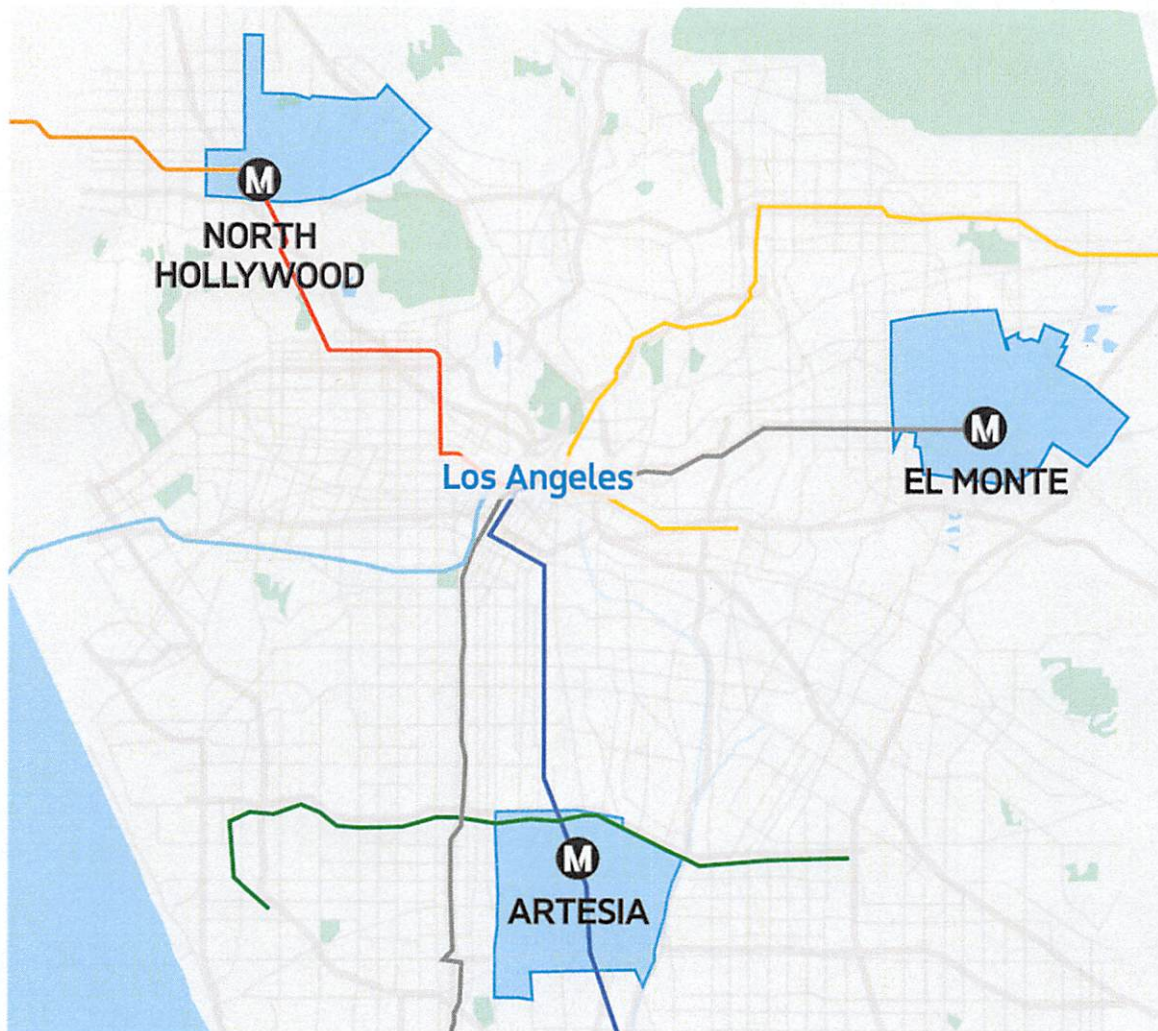

Attachment B - Mobility on Demand Preliminary Research Findings

Mode Shift

How did you get to/from the station before using Via?

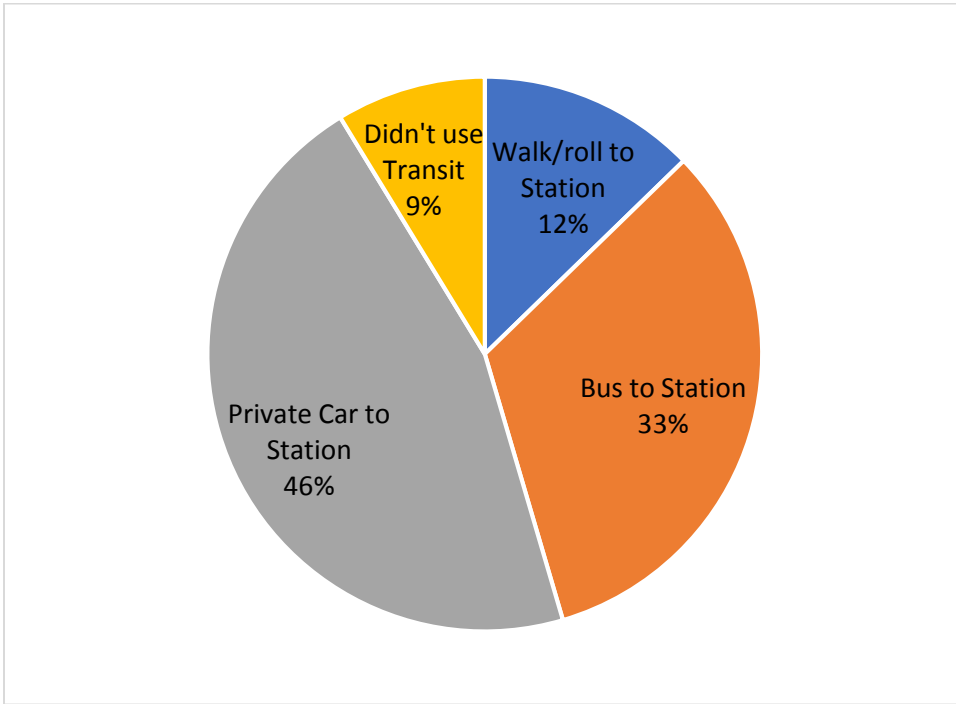

Do you have a car available you could have used to make this trip?

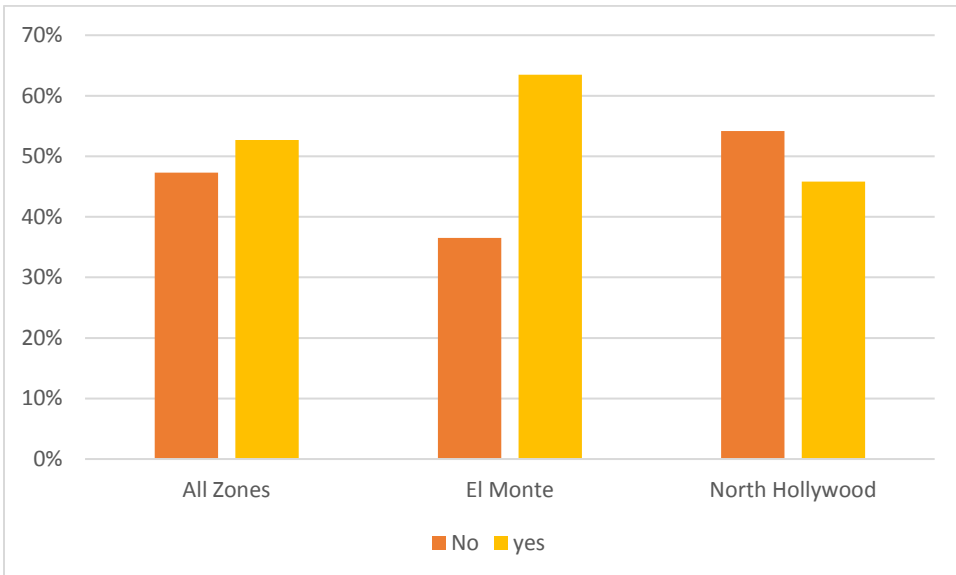

What is your annual household income?

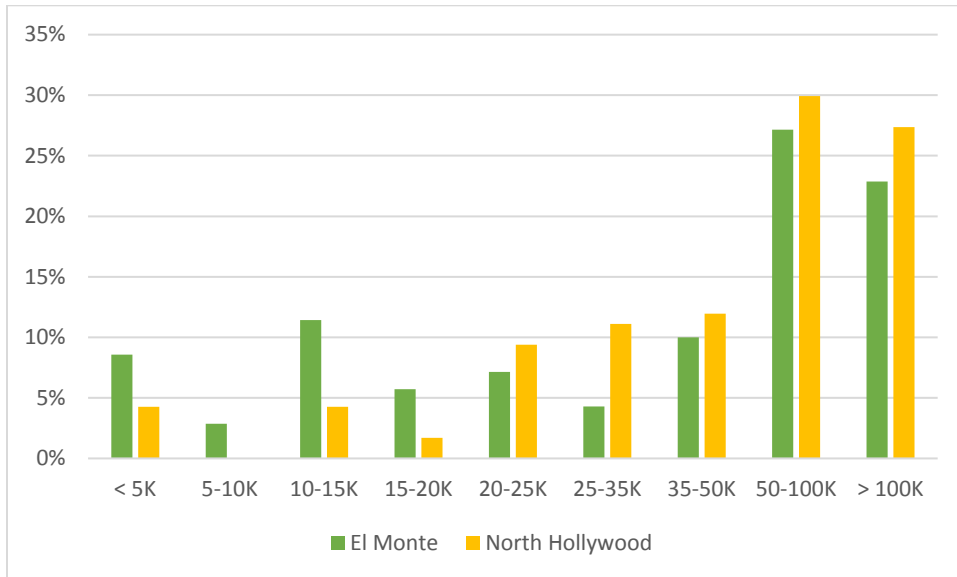

Do you identify as...?

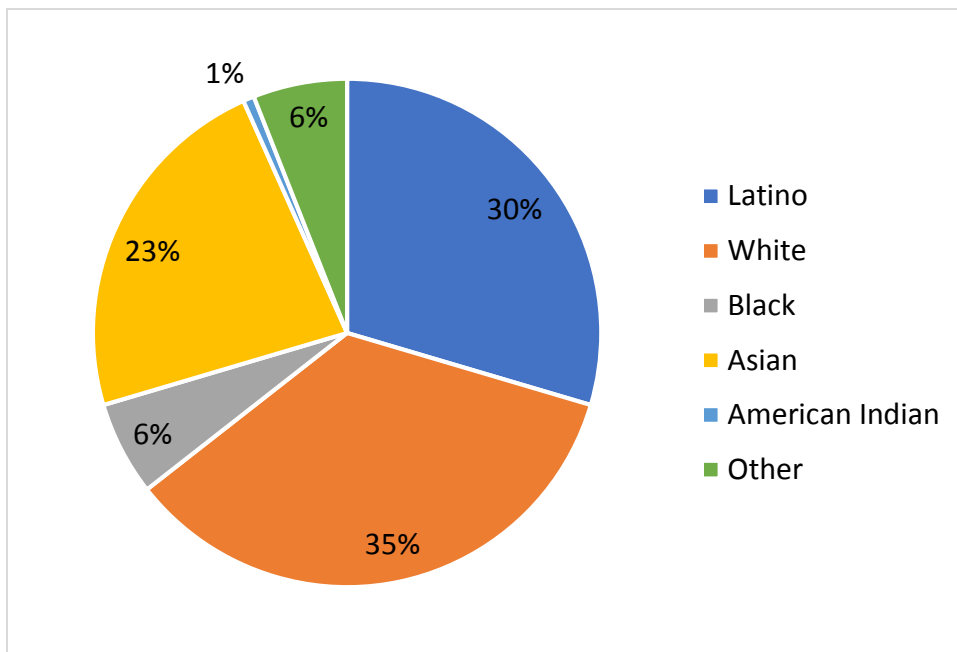

What is your age?

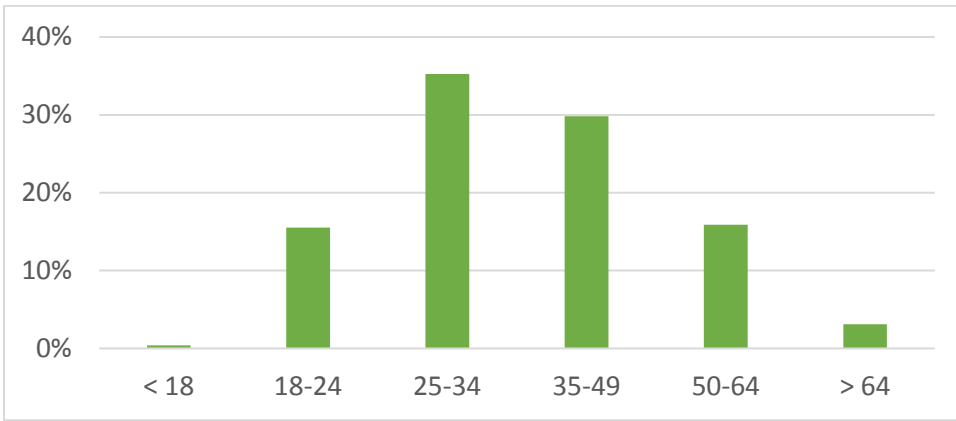

What is your gender identity?

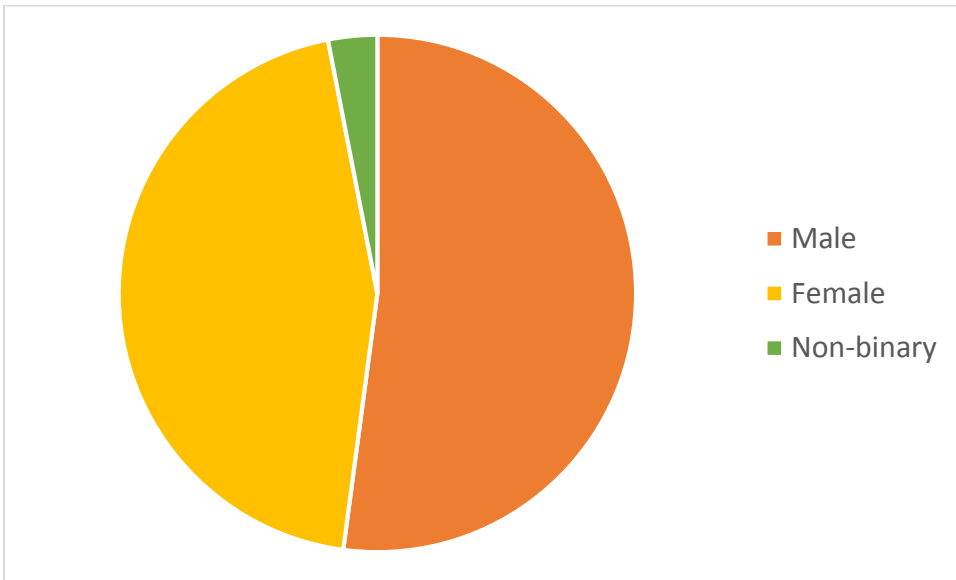

Attachment C – Service Areas

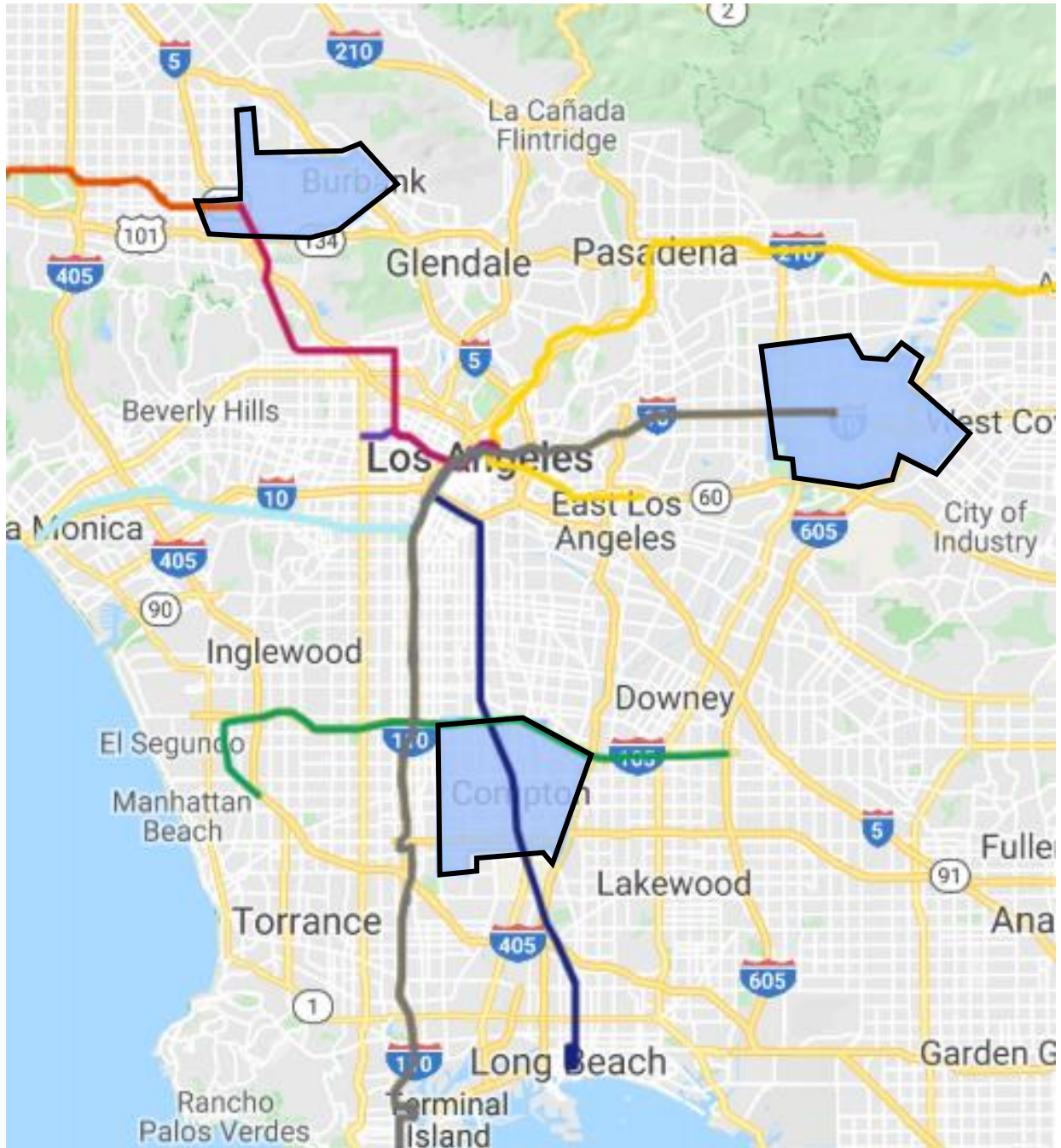

PROCUREMENT SUMMARY

MOBILITY ON DEMAND PILOT PROJECT / CONTRACT NO. PS121778000

1.	Contract Number: PS121778000		
2.	Contractor: NoMad Transit LLC		
3.	Mod. Work Description: Six-Month Term Extension to continue the pilot project with enhanced service design for additional research		
4.	Contract Work Description: Mobility on Demand pilot project		
5.	The following data is current as of: 12/19/19		
6.	Contract Completion Status		Financial Status
	Contract Awarded:	10/25/18	Contract Award Amount: \$2,506,410
	Notice to Proceed (NTP):	12/18/18	Total of Modifications Approved: \$0
	Original Complete Date:	1/28/20	Pending Modifications (including this action): \$1,530,332 \$2,180,332
	Current Est. Complete Date:	7/28/20	Current Contract Value (with this action): \$4,036,742 \$4,686,742
7.	Contract Administrator: Carolina Coppolo		Telephone Number: 213.922.4471
8.	Project Manager: Marie Sullivan		Telephone Number: 213.922.5667

A. Procurement Background

This Board Action is to approve the Contract Modification issued to extend the Contract six months in support of the Mobility on Demand (MOD) pilot project. The Contractor will continue to operate the MOD pilot project with enhanced service design for additional research.

This Contract Modification will be processed in accordance with Metro's Acquisition Policy and the contract type is a firm fixed unit price.

On October 25, 2018, the Board awarded a contract to NoMad Transit LLC to operate a first and last mile pilot service to/from the North Hollywood, Artesia, and El Monte stations, with an option to extend for a second year.

Refer to Attachment E – Contract Modification/Change Order Log.

B. Cost/Price Analysis

The recommended price has been determined to be fair and reasonable based upon an independent cost estimate (ICE), cost analysis, and technical evaluation. The contractor will be converting their independent contractor driver partners to operator employees in the option term to be compliant with AB5. The negotiated amount includes the increased hourly driver rate.

Proposal Amount	Metro ICE	Modification Amount
\$2,097,293 \$2,747,293	\$2,460,036 \$2,930,110	\$1,530,332 \$2,180,332

CONTRACT MODIFICATION/CHANGE ORDER LOG

MOBILITY ON DEMAND PILOT PROJECT / CONTRACT NO. PS121778000

Mod. No.	Description	Status (approved or pending)	Date	\$ Amount
1	Exercise Option Year with enhanced service design for additional research	Pending	Pending	\$1,530,332 <u>\$2,180,332</u>
	Modification Total:			\$1,530,332 <u>\$2,180,332</u>
	Original Contract:			\$2,506,410
	Total:			\$4,036,742 <u>\$4,686,742</u>



Board Report

File #: 2019-0853, **File Type:** Fare / Tariff / Service Change

Agenda Number: 16.

OPERATIONS, SAFETY, AND CUSTOMER EXPERIENCE COMMITTEE JANUARY 16, 2020

SUBJECT: PUBLIC REVIEW OF NEXTGEN TRANSIT FIRST SERVICE PLAN

ACTION: APPROVE RECOMMENDATION

RECOMMENDATION

CONSIDER:

1. AUTHORIZING the release of the NextGen Draft Transit First Service Plan for public review;
and
2. APPROVING updates to the Transit Service Policy to reflect the NextGen Regional Service Concept

BONIN AMENDMENT: Add a report back from OMB by April 2020 regarding funding options for the capital portion of the NextGen Transit First scenario.

ISSUE

In July 2019, the Metro Board approved the NextGen Regional Service Concept, which is the framework for restructuring Metro's bus routes and schedules for NextGen and includes:

1. Goals and objectives of the new bus network;
2. Measures of success;
3. Route and network design concepts based on public input and data analysis;
4. Framework for balancing tradeoffs that consider Metro's Equity Platform

Staff have updated the Board adopted Transit Service Policy (TSP) to reflect the Regional Service Concept which was used to develop the NextGen draft service plans. This report requests approval of the updates to the TSP and the release of the Draft Transit First Service Plan for public review starting February 2020.

BACKGROUND

In January 2018, Metro began the NextGen Bus Study aimed at reimagining the bus network to be more relevant, reflective of, and attractive to the diverse customer needs within Los Angeles County.

More specifically, the NextGen Bus Study aims to increase transit use within the County over the next decade by retaining current customers and attracting them to ride more often, reclaiming past customers, and recruiting new customers

The NextGen Bus Study is divided into four phases:

1. Conduct market research, travel demand analysis and existing service evaluation to identify areas of success, deficiency, and gaps within the network;
2. Establish a Regional Service Concept to guide the development of the NextGen Service Plan;
3. Develop the NextGen Service Plan, including routing, stop spacing, frequency, span of service, and coordination with municipal operators;
4. Implement the NextGen Service Plan through extensive engagement and public hearing process.

The first phase of the project consisted of understanding customers and what they want in a bus system. A significant effort went into understanding overall travel patterns within LA County using cell phone location data as well as an analysis of regional TAP use across 26 transit operators. A comprehensive evaluation of the existing bus network (Attachment A), broken down by routes and segments by time of day, was conducted to understand current successes as well as deficiencies and gaps in service. Significant public engagement was conducted with customers and residents with over 10 million touchpoints throughout the County via online engagement, print advertising, pop-up sessions, 260+ stakeholder and community meetings, on-board bus canvassing, and at 20 interactive public workshops to validate the market research, receive comments, and to gain valuable insight into route and area specific concerns and recommendations.

Based on the research and outreach conducted in Phase I, the Board adopted the Regional Service Concept in July 2019 which established:

1. Goals and objectives of the new bus network;
2. Measures of success;
3. Route and network design concepts based on public input and data analysis;
4. Framework for balancing tradeoffs that consider Metro's Equity Platform

This Regional Service Concept provides a planning framework to redesign the bus network.

Transit Service Policy

The policy choices set by the NextGen Regional Service Concept have been incorporated into an updated Transit Service Policy. This Board adopted document translates policies and objectives into criteria and thresholds to be used in designing and managing the Metro bus network. In addition to the changes from NextGen, other changes to the document have been incorporated to reflect the updated Title VI program, including service standards, definitions of what constitute major service changes, and the standards for determining disparate impact on minorities, and disproportionate burden for low income persons.

NextGen Draft Service Plan (Building a World Class Bus System)

In 2018 the Board adopted Metro Vision 2028 as the agency's strategic plan. This plan envisioned

building a World Class Transportation System in which a World Class Bus System is a cornerstone to its success. Building a World Class Bus System requires improving the attractiveness and competitiveness of the bus network. Attractiveness includes addressing issues such as safety and security, cleanliness, comfort, real time arrival information, easy fare payment, wayfinding and signage, and first/last mile access. Competitiveness requires developing a bus network that minimizes the overall travel time to complete a trip compared to the driving alternative. This travel time considers directness of route, access to the bus stop, waiting time, and onboard travel time.

NextGen's primary purpose is to improve the competitiveness of the bus network. However, through this process, improvements to certain aspects of attractiveness can also be achieved. The following outlines a strategy for how NextGen will set the foundation for building a World Class Bus System.

Step 1: Reconnect Scenario

Metro currently provides roughly 7 million revenue service hours (RSH) of bus service per year. The first step in creating a World Class Bus System is to redesign the routes and schedules to attract trips where and when there is the greatest market potential. The lessons learned in Phase 1 present a path forward for reinventing the bus network:

- **85% of LA County residents have used transit at least once in the past year**, THEREFORE, we should attempt to maintain coverage throughout the County by minimizing discontinued segments.
- **Fast/Frequent/reliable service is key**, THEREFORE, we need to create a competitive transit network that reduces overall travel time by optimizing all components of the trip, including walking, waiting, and riding.
- **Metro's current system is not always competitive to get people where they want to go**, THEREFORE routing should be adjusted to reflect the key origins and destinations identified in the cell phone location data.
- **The greatest opportunity to grow ridership is between midday & evening when many trips are short distance**, THEREFORE service levels should be improved for midday, evenings and weekends.
- **Need to integrate Metro's Equity Framework into the planning process**, THEREFORE service improvements should be prioritized for equity-focused areas.

A draft service plan has been developed based on the lessons learned to "reconnect" or realign routes and schedules based on where and when people travel today. Reconnect is estimated to increase ridership by 5% with no additional increase in revenue service hours.

Step 2: Transit First Scenario

Once the bus network is reestablished to reflect the travel patterns of today, the next step in building a World Class Bus System is to: 1) invest in speed and reliability infrastructure, 2) create safe &

comfortable waiting environments, 3) improve the boarding and riding experience, and 4) establish facilities to optimize layovers. These capital improvements create a more competitive and attractive bus network while saving resources to be reinvested into more service.

- Speed and Reliability Improvements - As bus system speeds continue to decline, Metro must allocate an additional \$10 million cumulatively every year to provide the same amount of service. Not only does this reduce the opportunity to increase service, it degrades our competitiveness and attractiveness. Therefore, investing to improve the speed and reliability of the bus system is critical to the success of NextGen. Some improvements can be implemented within METRO's control, such as optimizing stop spacing, all door boarding, and headway-based service management. However, other improvements can only be implemented through collaboration with local jurisdictions, including transit priorities, bus bulb outs, and bus only lanes. Under the Transit First scenario, \$750 million in capital improvements are proposed to support speed and reliability improvements for the regional bus network. This investment is anticipated to save 25%-34% in system speed if fully implemented.
- Customer Wait Environment - Through the significant public outreach conducted in Phase 1, as well as other Metro efforts such as the How Women Travel Study, we learned that an uncomfortable and unsecured wait environment is a significant barrier for customers in using the bus network. This is particularly concerning for women who account for over half of our customers and often travel with young children. Metro completed the Transfer Design Guideline in March 2018. Under the Transit First scenario, we plan to begin implementing the recommendations from this policy document at our busiest wait and transfer locations. This investment is anticipated to cost \$150 million and address several of the safety and comfort issues identified in the NextGen outreach and How Women Travel Study.
- Boarding and Riding Experience - Metro has implemented All Door Boarding on several lines, including Orange Line, Silver Line, Line 720 (Wilshire), and Line 754 (Vermont). Experience on the Silver Line showed that dwell times were reduced by 15% on average, on time performance improved, cash payment declined with more TAP penetration, and significant customer and operator satisfaction. Other strategies to improve boarding and on board experience include level boarding at key stops and improved on board information. These improvements are estimated at \$100 million systemwide.
- Layover Optimization - Due to limited curb space, many routes are extended purely to access a layover location. These unnecessary route extensions cost several million dollars in operating cost per year with little to no benefit to the customer. By investing in off street layover terminals to optimize layover locations, we can reallocate wasted resources and reallocate it to more productive use. In addition, these locations would provide facilities for better regional mobility coordination, a better wait and rest environment for customers and operators, improve bus service reliability, and opportunities for new en route Zero Emissions Bus (ZEB) charging infrastructure.

With the investment in this \$1 billion capital program, we expect to achieve resource savings by generating more revenue service miles/trips within the same revenue service hours. These savings would be reinvested into Transit First service improvements, including:

- Ensure that all regular bus lines operate 7 days per week, including weekend service on eight lines;
- Ensure no wider than 30 min headways on any line between 6:00 am and 7:00 pm;
- Expand owl (overnight) service on an additional eight lines;
- Increase weekday midday and evening service levels;
- Increase weekday evening service levels.

Investing “one time” capital dollars into transit supportive infrastructure would increase the attractiveness and competitiveness of the bus network, while freeing resources to reinvest into service enhancements. Under the Transit First scenario, these benefits are expected to generate a 15-20% increase in ridership (10-15% over Reconnect) without additional increases in revenue service hours.

Step 3: Future Funding Scenario

Should future funding be secured through efforts such as de-congestion pricing, additional resources can be added to the Transit First network. However, without disincentives for driving, there will be diminishing returns on benefits since most customers would already have been served well within the Transit First Scenario. Therefore a 34% increase in revenue service hours would only be expected to yield a 10% increase in ridership over Transit First.

Summary of Benefits

The following is a summary of benefits from each scenario described above.

	Existing Conditions	Reconnect Scenario	Transit First Scenario	Future Funding Scenario
Revenue Service Hours	7 million	7 million	7 million	9.4 million
Revenue Service Miles	75 million	75 million	82 million	95 million
# High Freq Lines ¹ (weekdays)	16	28	29	46
# High Freq Lines ¹ (weekends)	2	14	14	19
Pop within walk access to High Freq Lines (weekdays)	900k	2.15m	2.17m	2.96m

Pop within walk access to High Freq Lines (weekends)	630k	1.14m	1.18m	1.49m
Ridership Change ²	0	+5%	+15-20%	+25-30%
% Riders who lose convenient access to transit ³	0	0.3%	0.3%	0.3%

Notes

¹ Every 10 min or better

² Compared to Existing Conditions

³ Beyond a 5 min walk (.25 mile) to a transit stop

Recommendation

Based on the benefits and costs identified above, staff recommends that the Board approve the Transit First scenario as the NextGen Service Plan to be released for public review and comment starting February 2020. This scenario includes:

- Service adjustments recommended through the Reconnect scenario (revenue service hour neutral);
- \$1 billion in transit supportive capital infrastructure to improve speed and reliability, customer wait environment, boarding and riding experience, and layover optimization.
- Reinvestment of resource savings from speed infrastructure and layover optimization into additional revenue service as outlined above

If fully implemented, the Transit First scenario is expected to achieve a 15-20% increase in ridership over current levels.

FINANCIAL IMPACT

Approving the Transit First scenario for public review and updates to the Transit Service Policy will not have an impact on the FY20 budget. However, future implementation of any components of the Transit First scenario will be evaluated for financial impact at that time based on cost and implementation schedule. Funding will be identified and programmed into the appropriate annual budget.

IMPLEMENTATION OF STRATEGIC PLAN GOALS

Recommendation supports strategic plan goal #1: Provide high quality mobility options that enable people to spend less time traveling. The study also encompasses two sub-goals: 1) Target infrastructure and service investments towards those with the greatest mobility needs; and 2) Invest in a world class bus system that is reliable, convenient, safe, and attractive to more users for more trips.

NEXT STEPS

Should the Board approve the recommendations above, staff will begin the public outreach process to review all route and schedule changes within Transit First with stakeholders and the public. Public workshops will be held between February and March 2020 followed by community and stakeholder meetings/briefings. The formal public hearing process to approve the service changes for implementation is scheduled to begin in June 2020 with Service Council consideration of approval in August 2020. If approved by the Service Councils, the final NextGen service plan will be presented to the Board for approval in September 2020. Assuming approval, the service plan will be implemented in two to three starting in December 2020, then June 2021 and possibly December 2021.

As a complementary effort, staff will continue to work with LADOT through the established traffic engineering working group to develop annual work programs to design, engineer, fund and construct the speed and reliability infrastructure. The customer experience and layover infrastructure will also be further defined and scoped. The individual elements of the Transit First capital program will be presented to the Board for approval of Life of Project (LOP) budget as they are defined and programmed through the annual budget development process for implementation.

ATTACHMENTS

Attachment A - NextGen Transit First service plan
Attachment B - Transit Service Policy

Prepared by: Conan Cheung, Sr. Executive Officer, Service Development, (213)418-3034

Reviewed by: James T. Gallagher, Chief Operations Officer, (213)418-3108

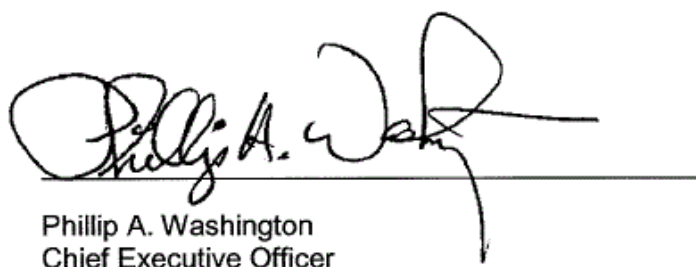

Phillip A. Washington
Chief Executive Officer

Transit First Service Plan

Core Network

Key spines in the network

Highest investment in customer and operations infrastructure

53% of today's bus riders use one of these top 25 corridors

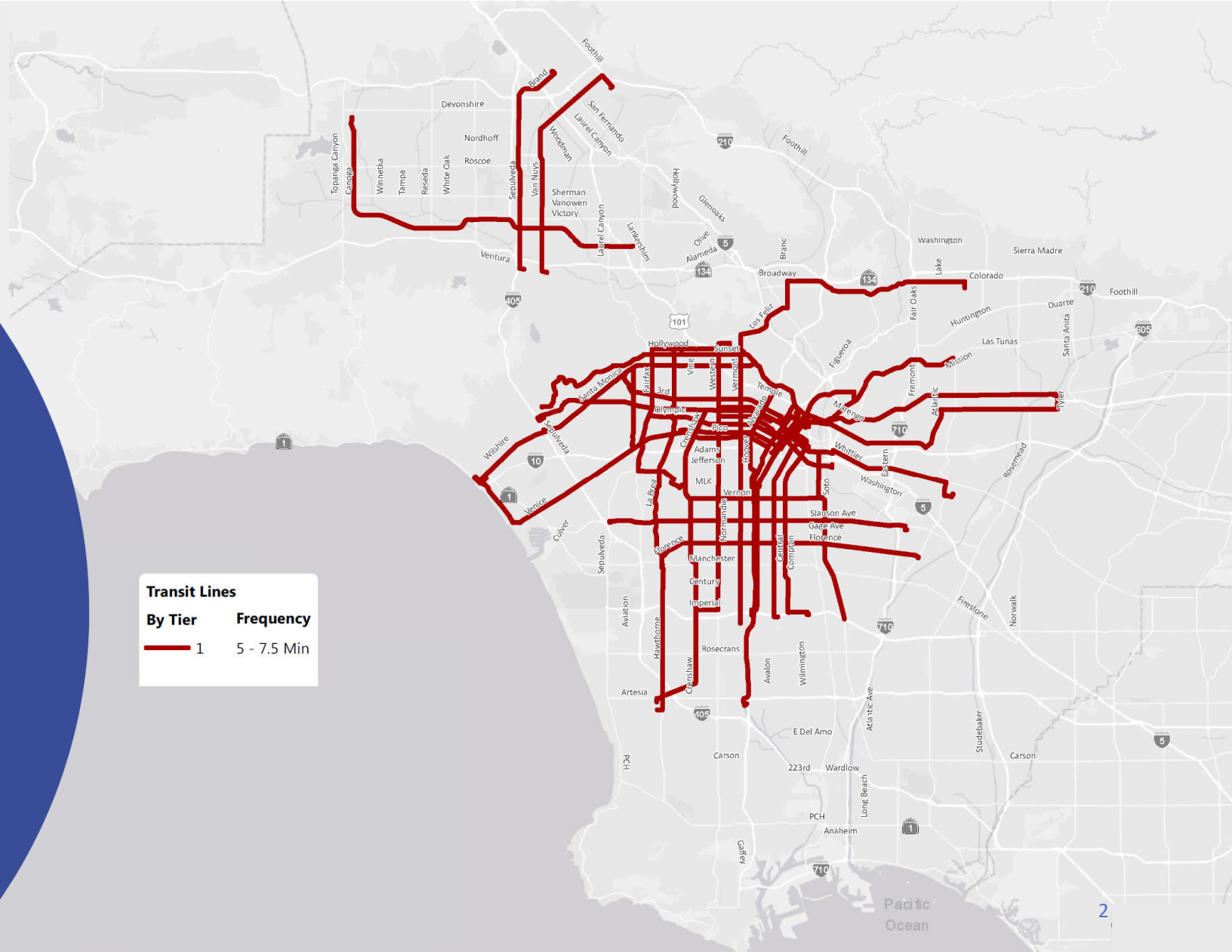

Convenience Network

81% of Metro's bus riders use a Tier 1 or 2 corridor

Completes the spontaneous-use network

Focuses on network continuity

High investment in customer and operations infrastructure

28% of today's bus riders use one of the 19 Tier 2 corridors

Transit Lines	
By Tier	Frequency
1	5 - 7.5 Min
2	10 Min

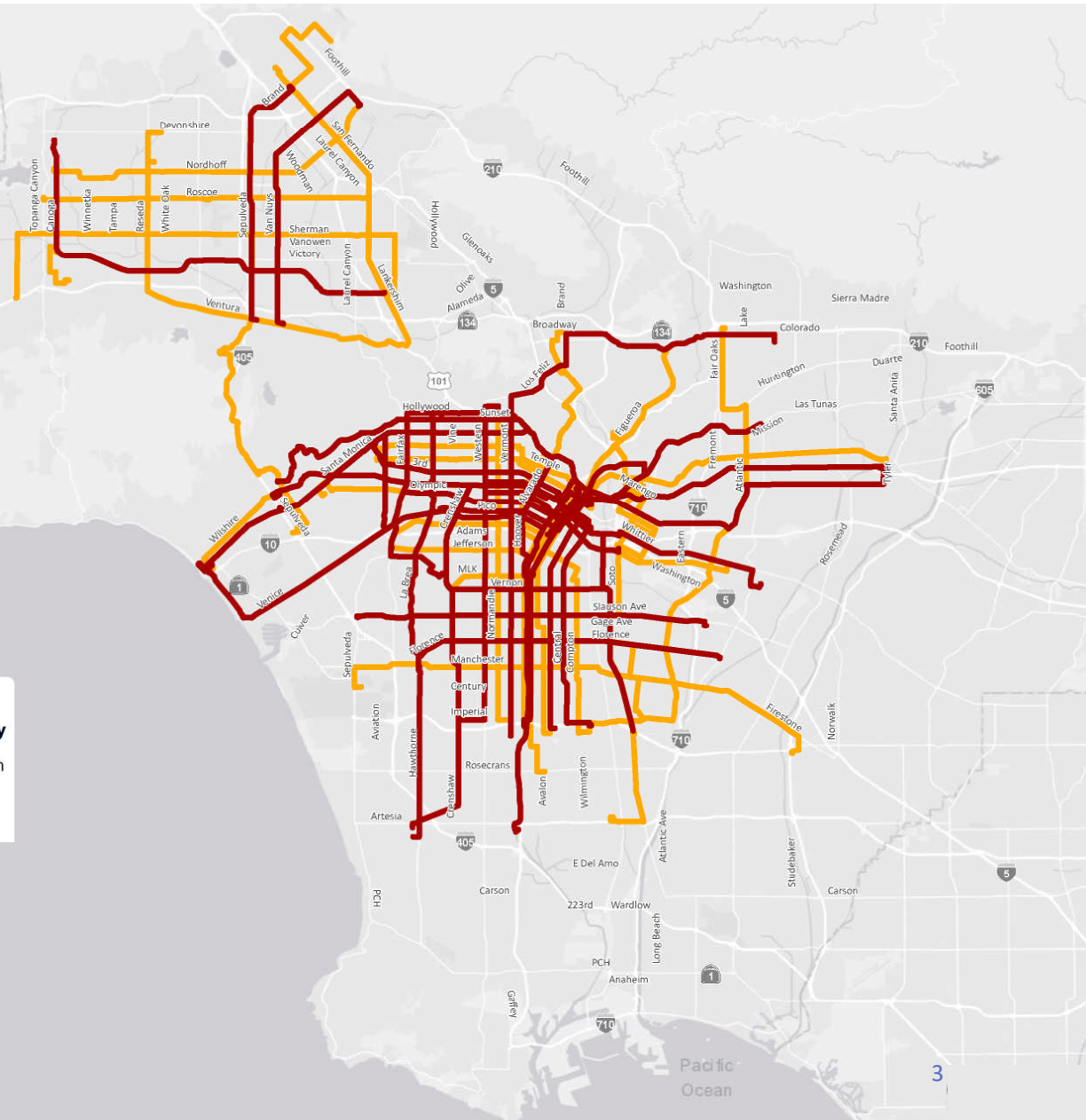

Connectivity Network

Completes the frequent network

Moderate investment in customer and operations infrastructure

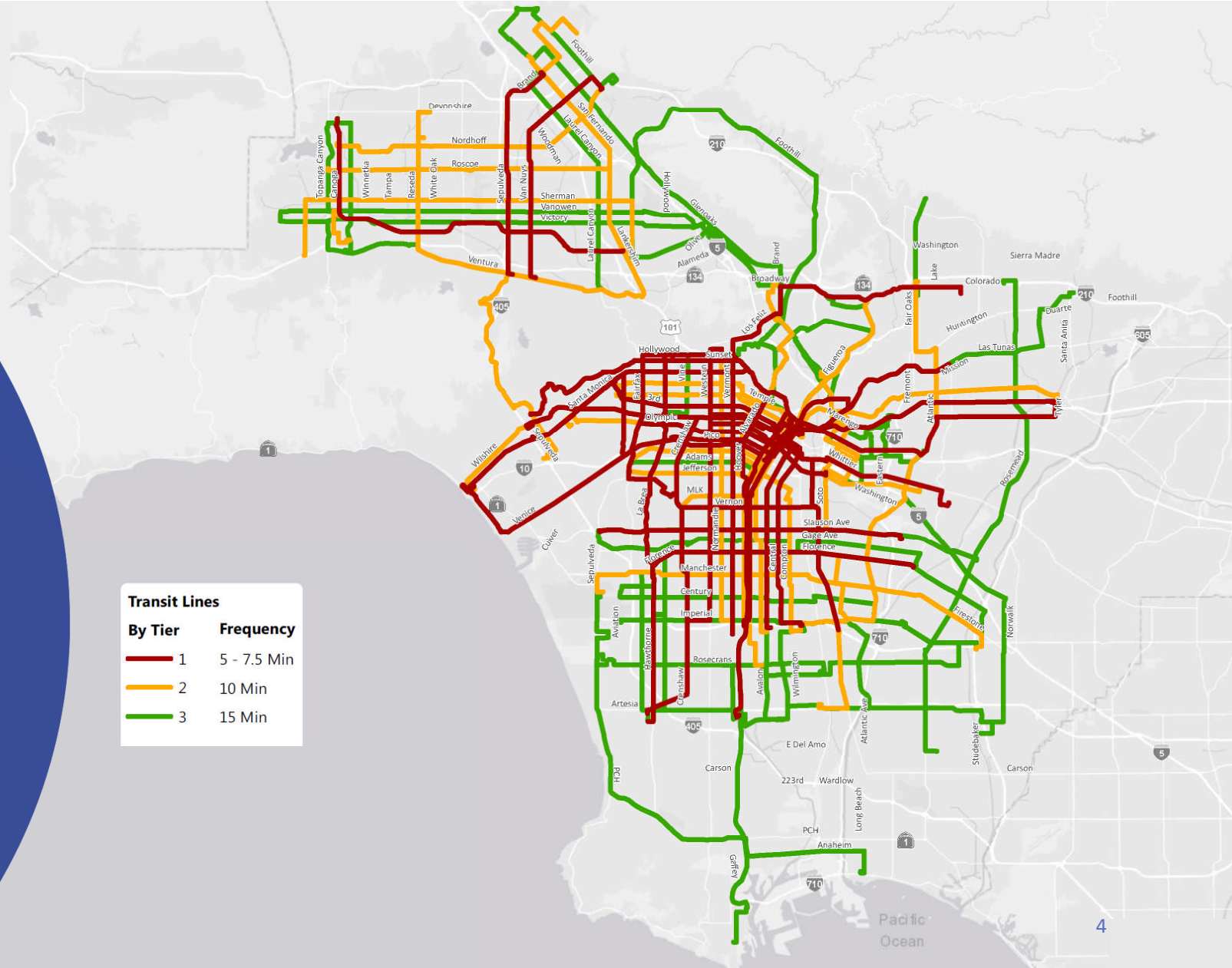

Community Network

Focuses on community travel in areas with lower demand; also includes Expresses

Minimal investment in customer and operations infrastructure

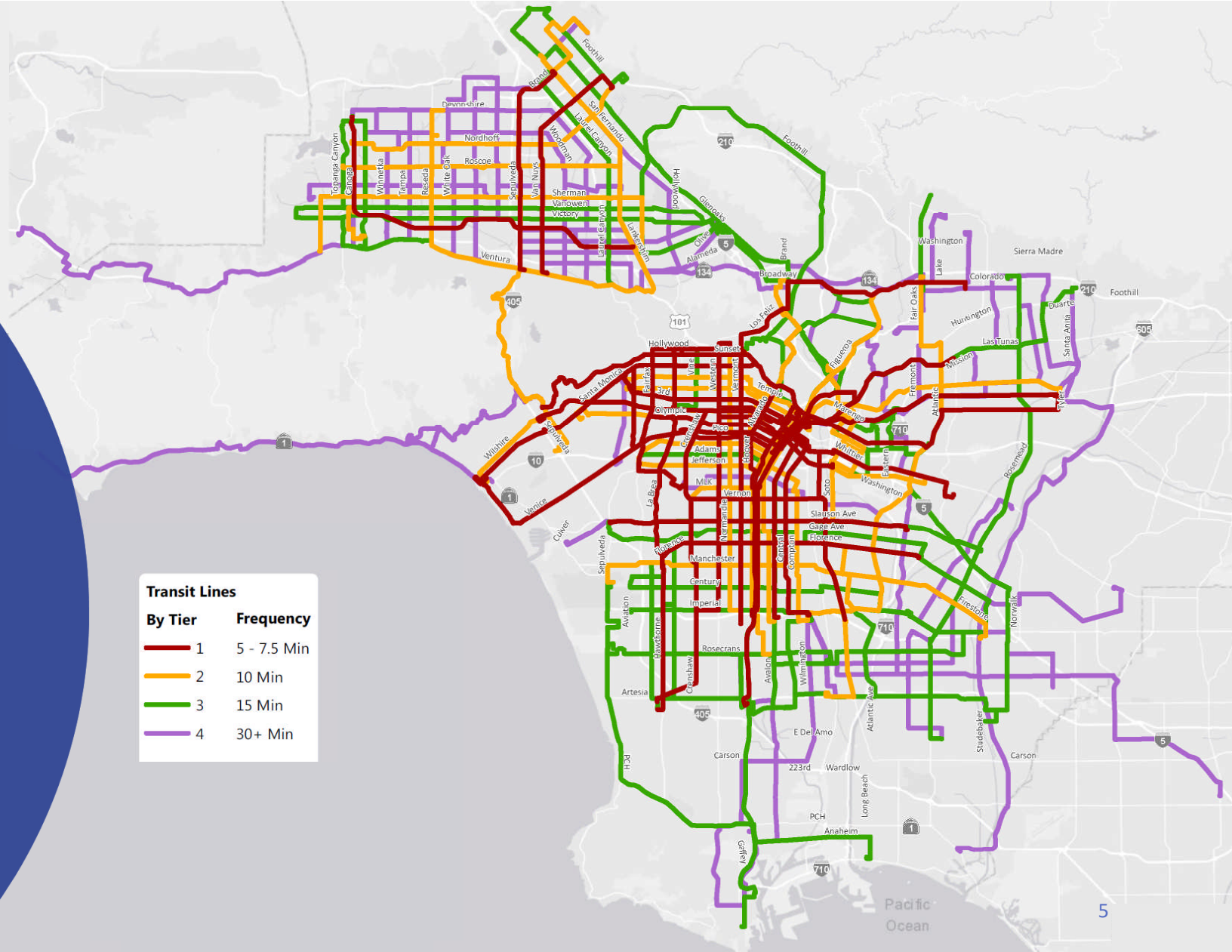

Full Network

The full network complements Muni lines, Metro Rail, & Metrolink services

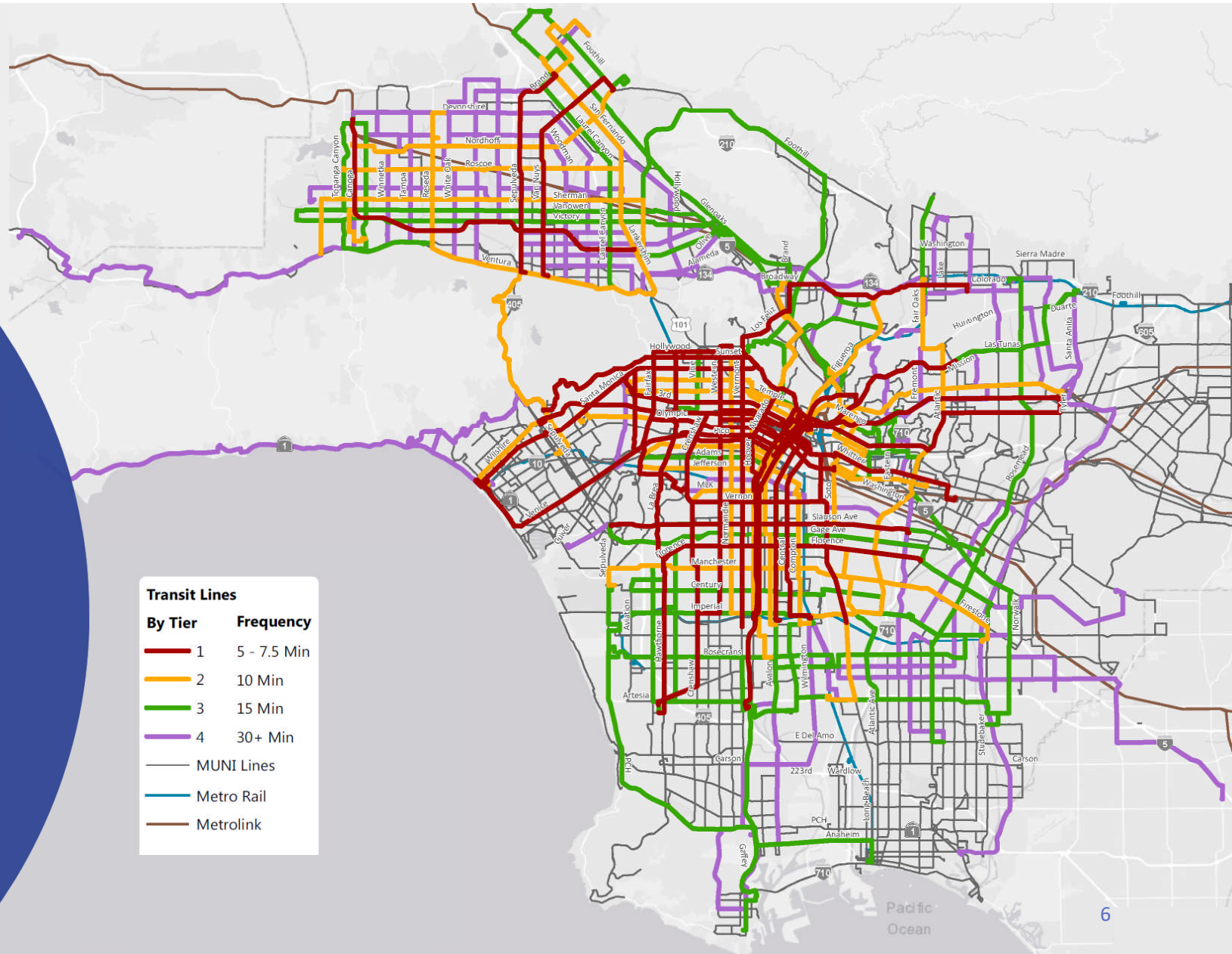

Attachment A
NextGen Transit First Service Change Proposals by Line

Line	Service Change Proposal	Existing Weekday Frequency						Proposed Weekday Frequency						Existing Saturday Frequency						Proposed Saturday Frequency						Existing Sunday Frequency						Proposed Sunday Frequency								
		AM Peak	Midday	PM Peak	Evening	Late Night	Owl	AM Peak	Midday	PM Peak	Evening	Late Night	Owl	AM Peak	Midday	PM Peak	Evening	Late Night	Owl	AM Peak	Midday	PM Peak	Evening	Late Night	Owl	AM Peak	Midday	PM Peak	Evening	Late Night	Owl	AM Peak	Midday	PM Peak	Evening	Late Night	Owl			
R2	New Line 2: Merge Lines 2 and 302 on Sunset Bl with Line 200 (Alvarado/Hoover): •New Line 2 would follow existing Lines 2 & 302 routes on Sunset Bl between UCLA and Hollywood, merging with existing Line 200 at Sunset & Alvarado to Exposition Park/USC via Alvarado, Hoover, Figueroa and MLK Jr New Line 2 would provide: •New direct route between USC/Exposition Park and Hollywood •High frequency service for all bus stops on Sunset Blvd and Alvarado St •Underutilized bus stops would be consolidated to balance speed, reliability, and accessibility •Line 4 would remain serving Sunset Bl east of Alvarado St through downtown LA	15	15	15	20	30	60	7.5	12	7.5	15	30	60	12	15	15	20	30	60	12	12	12	15	30	60	20	20	20	30	30	60	12	12	12	15	30	60			
R302		10	-	15	-	-	-	-	-	-	-	-	-	-	-	-	-	-	-	-	-	-	-	-	-	-	-	-	-	-	-	-	-	-	-	-				
R602		-	-	-	-	-	-	30	30	30	30	60	-	-	-	-	-	-	30	30	30	30	30	60	-	-	-	-	-	-	30	30	30	30	30	60				
R200		8	12	7	20	40	-	-	-	-	-	-	12	12	10	20	40	-	-	-	-	-	-	-	20	13	10	25	40	-	-	-	-	-	-	-				
Sunset/ Alvarado	More frequent service would be provided all day on weekdays for Line 602.	6	15	7.5	20	30	60	7.5	12	7.5	15	30	60	12	15	15	20	30	60	12	12	12	15	30	60	20	20	20	30	30	60	12	12	12	15	30	60			
R4	New Line 4: Merge Lines 4 and 704 on Santa Monica Bl: •New Line 4 would follow the existing Line 4 & 704 routes between downtown Santa Monica and downtown LA via Santa Monica Bl and Sunset Bl •Bus stops between Westwood and downtown LA would be adjusted through consolidation of underutilized stops to balance speed, reliability, and accessibility, with bus stops for existing Line 704 retained between Westwood and downtown Santa Monica. •More frequency for new Line 4 bus stops between Westwood and downtown LA.	10	15	10	20	20	25	12	15	12	20	30	30	15	15	12	20	20	30	15	15	15	20	30	30	20	15	15	25	25	25	15	15	15	20	30	30			
RS4		-	-	-	-	-	-	12	15	12	20	30	60	-	-	-	-	-	-	15	15	15	20	30	60	-	-	-	-	-	-	15	15	15	20	30	60			
R704		10	15	10	20	20	-	-	-	-	-	-	20	20	20	25	25	-	-	-	-	-	-	-	30	20	20	25	25	-	-	-	-	-	-	-				
Santa Monica		5	7.5	5	10	10	25	6	7.5	6	10	15	20	9	9	7.5	12	12	30	7.5	7.5	7.5	10	15	20	12	9	9	13	13	25	7.5	7.5	7.5	10	15	20			
R10	Line 10 has no changes and would continue to operate in partnership with Line 48. Buses continuing to change between these two lines at Temple/Figueroa in downtown LA. Line 10 would have more frequency during midday and evening hours on weekdays.	8	20	10	30	60	60	10	15	10	15	30	-	20	20	20	18	60	60	20	20	20	20	30	-	30	20	20	40	60	60	20	20	20	20	30	-			
R14	Line 14 would continue between downtown Los Angeles to Beverly/San Vicente via Beverly Bl and then travel north on San Vicente to Santa Monica Blvd then connect to Line 4: •Line 14 would have more frequency during midday and evening hours on weekdays. •Existing Line 14 segment west of Beverly/San Vicente to Pico Bl via Beverly Dr would be discontinued due to underutilized service. Nearest alternative bus service would be on Robertson Bl (Line 17), Santa Monica Bl (Line 4), Wilshire Bl (Line 20), Olympic Bl (Line 28), and Pico Bl (Big Blue Bus Line 7). •Line 14 would continue to operate in partnership with Line 37, with buses still changing to Line 37 at 1st/Beadry in downtown LA	6	15	8	15	60	60	10	15	10	15	30	-	25	20	17	30	60	60	20	20	20	20	30	-	25	20	20	25	60	60	20	20	20	20	30	-			
R16	New Line 16: Merge Lines 16, 17, and 316.	10	10	20	15	30	-	6	7.5	6	10	15	60	10	8	6	10	20	-	7.5	7.5	7.5	10	15	30	12	8	8	20	20	-	7.5	7.5	7.5	10	15	30			
R17	New Line 16 will operate between downtown LA and 3rd St/San Vicente via 3rd St, then north on San Vicente to Santa Monica Bl to connect with Line 4: •Line 16 and 316 would no longer continue west of 3rd St/San Vicente at Beverly Hills on Burton due to underutilized service	25	60	30	60	-	-	-	-	-	-	-	-	-	-	-	-	-	-	-	-	-	-	-	-	-	-	-	-	-	-	-	-	-	-	-	-			
R617	•Lines 4 (Santa Monica Bl) or Line 28 (Olympic Bl) would be available service at Century City •New Line 16 will have more frequency during midday and evening hours on weekdays	-	-	-	-	-	-	30	30	30	30	-	-	-	-	-	-	-	-	45	45	45	45	-	-	-	-	-	-	-	-	45	45	45	45	-	-			
R316	New Line 617 would operate between E Line (Expo) Culver City Station to Cedars-Sinai Medical Center/Beverly Center via Robertson Bl, to operate more reliably: •New Line 617 will have more frequency during midday and evening hours on weekdays, as well as new Saturday and Sunday service	8	-	8	-	-	-	-	-	-	-	-	-	-	-	-	-	-	-	-	-	-	-	-	-	-	-	-	-	-	-	-	-	-	-	-	-			
3rd		4	9	5	12	30	-	6	7.5	6	10	15	60	10	8	6	10	20	-	7.5	7.5	7.5	10	15	30	12	8	8	20	20	-	7.5	7.5	7.5	10	15	30			
R18	New Line 18: Merge Line 18 and Line 720. New Line 18 would operate between Metrolink Montebello-Commerce Station and downtown LA: •More frequency for all new Line 18 bus stops between East LA and downtown LA •New Line 18 service would continue between downtown LA and Wilshire/Western via 6th St •Underutilized bus stops would be consolidated to balance speed, reliability, and accessibility.	5	10	8	22	30	60	6	7.5	6	10	15	30	7.5	12	12	25	30	60	7.5	7.5	7.5	10	15	30	15	15	12	25	30	60	7.5	7.5	7.5	10	15	30			
RS20		10	12	10	20	30	30	10	10	10	15	-	-	20	15	15	25	30	30	12	12	12	15	-	-	25	20	20	20	30	30	12	12	12	15	-	-			
RL20	New High Frequency Line 20: Merge Line 20 and Line 720 between downtown Santa Monica and downtown LA via Wilshire Bl., following the existing Line 20/720 route: •More frequency for all new Line 20 bus stops between Westwood and downtown LA •Underutilized Line 20 bus stops between Westwood and downtown LA would be consolidated to balance speed, reliability, and accessibility, •New Line 20 would serve existing Line 720 stops west of Sepulveda Bl to Santa Monica •New Line R20 would operate peak periods weekdays serving existing Line 720 stops between downtown LA and Santa Monica	10	10	4	10	15	-	10	-	10	-	-	-	12	10	8	10	15	-	-	-	-	-	-	-	20	10	10	15	15	-	-	-	-	-	-	-			
Wilshire		5	5	5	6	10	30	5	5	5	7.5	15	30	-	-	-	-	-	-	6	6	6	7.5	15	30	-	-	-	-	-	-	6	6	6	7.5	15	30			
R28	New High Frequency Line 28: Merge Line 28 & Line 728. New Line 28 would operate between Century City, downtown LA and Eagle Rock via Olympic Bl between Century City and downtown LA New Line 684 will link Gold Line Lincoln/Cypress Station and Eagle Rock: •More frequency during weekdays and weekends at all bus stops between Century City and downtown LA •Underutilized stops between Century City and downtown LA on Olympic Bl would be consolidated to balance speed, reliability, and accessibility, •New Line 684 would link Gold Line Lincoln/Cypress Station and Eagle Rock via existing Line 28. •Line 45 would serve the section of Line 28 on Broadway between downtown LA and Avenue 26	12	30	15	30	30	60	15	20	15	15	30	-	15	12	12	20	30	60	15	15	15	15	30	-	18	15	15	25	30	60	15	15	15	15	30	-			
RS28		-	-	-	-	-	-	15	20	15	-	-	-	-	-	-	-	-	-	-	-	-	-	-	-	-	-	-	-	-	-	-	-	-	-	-				
R684		-	-	-	-	-	-	30	30	30	30	60	-	-	-	-	-	-	60	30	30	60	60	-	-	-	-	-	-	60	30	30	60	60	-	-	-	-	-	-
R728		10	20	12	30	-	-	-	-	-	-	-	-	-	-	-	-	-	-	-	-	-	-	-	-	-	-	-	-	-	-	-	-	-	-	-				
Olympic		6	12	7	15	30	60	7.5	10	7.5	15	30	-	15	12	12	20	30	60	15	15	15	15	30	-	18	15	15	25	30	60	15	15	15	15	30	-			
R30	New Frequent Line 30: Merge Lines 30 & 330 between West Hollywood and Gold Line Indiana Station via San Vicente Bl, Pico Bl, and 15th St, via existing Lines 30/330 between Pico Rimpau Transit Center and Gold Line Little Tokyo/Arts District Station: •Existing Line 30/330 service on San Vicente Bl would be discontinued, with alternative bus service available on Olympic Bl (Line 28), Wilshire Bl (Lines 20, 320), 3rd St (Line 16), Beverly Bl (Line 14), Santa Monica Bl (Line 4) •Existing Line 30 service between Little Tokyo and Indiana Gold Line stations would be eliminated, with alternative service available on the Gold Line •Underutilized bus stops will be consolidated on Pico Bl to balance speed, reliability, and accessibility.	12	12	12	10	30	60	10	10	10	15	30	-	8	12	10	20	30	60	15	15	15	15	30	-	15	12	10	25	30	60	15	15	15	15	30	-			
R330		12	-	20	-	-	-	-	-	-	-	-	-	-	-	-	-	-	-	-	-	-	-	-	-	-	-	-	-	-	-	-	-	-	-	-				
Pico		6	12	7	10	30	60	10	10	10	15	30	-	8	12	10	20	30	60	15	15	15	15	30	-	15	12	10	25	30	60	15	15	15	15	30	-			
R33	New Line 33: Merge Lines 33 & 733 on Venice Bl, following existing Line 33/733 alignment between downtown Santa Monica and downtown LA via Venice Bl: •New Line 33 route would be modified to serve Pico Station in downtown LA •Increased service frequency for all new Line 33 bus stops between Santa Monica and downtown LA •Underutilized stops between Santa Monica and downtown LA would be consolidated to balance speed, reliability, and accessibility	12	20	12	20	30	30	7.5	10	7.5	10	30	60	20	20	13	15	25	30	10	10	10	10	30	60	30	20	20	20	25	30	10	10	10	10	30	60			
R733		15	20	15	20	30	-	-	-	-	-	-	20	20	20	30	30	-	-	-	-	-	-	-	20	20	20	20	30	-	-	-	-	-	-	-				
Venice		7	10	7	10	15	30	7.5	10	7.5	10	30	30	10	10	7.5	10	15	30	10	10	10	10	30	60	12	10	10	10	15	30	10	10	10	10	30	60			
R35	Line 35 has no route changes: •More frequency during midday and late-night hours on weekdays	10	15	12	20	60	-	12	12	12	15	30	-	15	15	15	40	60	-	20	15	15	20	30	-	40	20	20	40	60	-	20	15	15	20	30	-			
R40	New High-Frequency Line 40: Merge Lines 40 & 740. This new line 40 would operate between LA Union Station and downtown Inglewood Station via Broadway, ML King Jr Bl, Crenshaw Bl, Florence Av: •More frequency for all bus stops on Broadway, ML King Jr Bl, Crenshaw Bl, and Florence Av •Underutilized bus stops will be consolidated on Broadway, ML King Jr Bl, Crenshaw Bl, and Florence Av to balance speed, reliability, and accessibility •Line 40 Overnight Owl service between LAX and downtown LA would be discontinued, with alternative Owl service available on Lines 45 and 111 •New Line 212 would serve La Brea Av, Hawthorne Bl south of downtown Inglewood Station ending at South Bay Galleria	12	20	15	15	25	60	10	10	10	15	30	-	20	20	20	24	60	60	15	15	15	15	30	-	20	20	20	20	60	60	15	15	15	15	30	-			
R740		18	30	18	20	-	-	-	-	-	-	-	20	30	20	20	-	-	-	-	-	-	-	-	-	-	-	-	-	-	-	-	-	-	-	-				
Hawthorne		7.5	12	8	8	25	60	10	10	10	15	30	-	10	12	10	12	60	60	15	15	15	15	30	-	20	20	20	20	60	60	15	15	15	15	30	-			

Line	Service Change Proposal	Existing Weekday Frequency						Proposed Weekday Frequency						Existing Saturday Frequency						Proposed Saturday Frequency						Existing Sunday Frequency						Proposed Sunday Frequency					
		AM Peak	Midday	PM Peak	Evening	Late Night	Owl	AM Peak	Midday	PM Peak	Evening	Late Night	Owl	AM Peak	Midday	PM Peak	Evening	Late Night	Owl	AM Peak	Midday	PM Peak	Evening	Late Night	Owl	AM Peak	Midday	PM Peak	Evening	Late Night	Owl	AM Peak	Midday	PM Peak	Evening	Late Night	Owl
R45	New High Frequency Line 45: Merge Lines 45 & 745 on Broadway St: •New Line 45 would follow existing route between Harbor Freeway Station, downtown LA, and Lincoln Heights via Broadway St •More frequency for all new Line 45 bus stops •Underutilized bus stops on Broadway St would be consolidated to balance speed, reliability, and accessibility •Line 127 will replace the segment of Line 45 south of Harbor Freeway Station on 117th St, Broadway St, El Segundo Bl, and Main St to San Pedro & Rosecrans (see Line 127 information sheet)	5	15	10	25	60	60	5	7.5	5	10	30	60	9	8	15	30	60	60	7.5	7.5	7.5	15	30	60	20	12	15	30	60	60	7.5	7.5	7.5	15	30	60
R745		8	15	10	30	-	-	-	-	-	-	-	-	12	18	20	20	-	-	-	-	-	-	-	-	30	30	30	30	-	-	-	-	-	-	-	-
Broadway		3	7.5	5	15	60	60	5	7.5	5	10	30	60	6	6	8	12	60	60	7.5	7.5	7.5	15	30	60	12	9	10	15	60	60	7.5	7.5	7.5	15	30	60
R51	New Line 51: Merge Lines 51, 52, 352 on San Pedro St and Avalon Bl. New Line would follow existing routes between downtown LA, San Pedro St, and Avalon Bl, with a new southern terminus at Cal State Dominguez Hills •Lines 51/52/351 would not operate between downtown LA and Wilshire/Vermont, with alternative service available on Wilshire Bl (Line 20) and 8th St (Line 66) •Line 127 would replace Lines 51/351 on Compton Bl and Line 52 on Victoria St (see Line 127 information sheet) •More frequency would be provided for all bus stops on San Pedro St and Avalon Bl, with highest frequency provided north of the Green Line Avalon Station •Underutilized bus stops would be consolidated to balance speed, reliability, and accessibility.	10	24	20	15	60	60	15	15	15	30	30	60	10	7.5	10	20	60	-	20	20	20	20	30	60	30	10	10	60	60	-	20	20	20	20	30	60
R551		-	-	-	-	-	-	15	15	15	-	-	-	-	-	-	-	-	-	20	20	20	-	-	-	-	-	-	-	-	-	20	20	20	-	-	-
R52		20	24	20	60	-	-	-	-	-	-	-	-	30	30	30	40	-	-	-	-	-	-	-	-	30	20	30	60	-	-	10	10	10	20	30	60
R351		20	-	20	-	-	-	-	-	-	-	-	-	-	-	-	-	-	-	-	-	-	-	-	-	-	-	-	-	-	-	-	-	-	-	-	-
Avalon	5	12	6	12	60	60	7.5	7.5	7.5	30	30	60	7.5	6	7.5	12	60	-	10	10	10	20	30	60	15	6	7.5	30	60	-	10	10	10	20	30	60	
R53	Line 53 between downtown LA and Cal State Dominguez Hills via Central Av would be changed as follows: •More frequency during the midday and evening hours on weekdays •Reroute Line 53 to serve the A Line (Blue) Line Willowbrook/Rosa Parks Station (instead of Green Line Avalon Station) to connect with both the A (Blue) Line and Green Line •Selected Line 53 trips will continue south of the A Line (Blue) Willowbrook/Rosa Parks Station to Cal State Dominguez Hills •Reroute Line 53 in downtown LA from Beaudry Av to Olive St to serve more destinations and a new connection to Line 4 (Line 55 will replace Line 53 on Beaudry Ave)	8	15	8	30	60	-	20	20	20	20	30	-	12	15	15	20	60	60	20	20	20	20	30	-	30	20	20	30	60	60	20	20	20	20	30	-
R553		-	-	-	-	-	-	20	20	20	-	-	-	-	-	-	-	-	-	-	-	-	-	-	-	-	-	-	-	-	-	-	-	-	-	-	-
Central		8	15	8	30	60	-	10	10	10	20	30	-	12	15	15	20	60	60	20	20	20	20	30	-	30	20	20	30	60	60	20	20	20	20	30	-
R55	New Line 55: Merge Lines 55 & 355 between downtown LA and Willowbrook/Rosa Parks Station via Adams Bl and Compton Av: •New Line 55 would follow existing Line 55/355 route with all trips ending at Willowbrook/Rosa Parks Station •More frequency for all bus stops on Adams Bl and Compton Av •Underutilized stops would be consolidated to balance speed, reliability, and accessibility •Line 55 in downtown LA would be rerouted on Beaudry Av, maintaining Metro rail connections •Eliminate Line 55 segment via Firestone Station to travel direct on Compton Av •Underutilized late-night Owl service would be discontinued. Nearest alternative late night Owl service would be Avalon Bl (Line 51)	15	20	15	60	60	60	12	12	12	15	30	60	12	15	15	30	60	60	20	20	20	20	30	60	30	23	23	60	60	60	20	20	20	20	30	60
R355		20	-	20	-	-	-	-	-	-	-	-	-	-	-	-	-	-	-	-	-	-	-	-	-	-	-	-	-	-	-	-	-	-	-	-	-
Adams/Compton		8	20	8	60	60	60	12	12	12	15	30	60	12	15	15	30	60	60	20	20	20	20	30	60	30	23	23	60	60	60	20	20	20	20	30	60
R60	New High Frequency Line 60: Merge Lines 60 & 760 on Long Beach Blvd between downtown LA, Green Line Long Beach Blvd and A Line (Blue) Artesia Stations: •New Line 60 would follow the existing Line 60 route between downtown LA and A Line (Blue) Artesia Station •High frequency service would be provided for all new Line 60 bus stops •More high frequency would be available north of Green Line Long Beach Bl Station •Underutilized bus stops on Santa Fe Av and Long Beach Bl would be consolidated to balance speed, reliability and accessibility •New Line 60 would include a reroute in downtown LA from Figueroa St to Olive St	7.5/15	15	7.5/15	20	23	60	10	10	10	15	30	60	15	10	15	30	34	60	10	10	10	15	30	60	20	12	12	30	34	60	10	10	10	15	30	60
R560		-	-	-	-	-	-	10	-	10	-	-	-	-	-	-	-	-	-	-	-	-	-	-	-	-	-	-	-	-	-	-	-	-	-	-	-
R760		12	20	15	30	-	-	-	-	-	-	-	-	20	30	25	60	-	-	-	-	-	-	-	-	-	-	-	-	-	-	-	-	-	-	-	-
Long Beach Blvd	5/7.5	8	5/7.5	12	23	60	5	10	5	15	30	30	9	7.5	10	20	34	60	10	10	10	15	30	60	20	12	12	30	34	60	10	10	10	15	30	60	
R62	New Line 262: New Line 262 will operate between East LA College, Gold Line Atlantic Station, and Los Cerritos Center, via Atlantic Ave, Telegraph Rd, Pioneer Bl: •Line 62 will be discontinued between downtown Los Angeles and Hawaiian Gardens via Telegraph Rd, Norwalk Bl, and Pioneer Bl. This would remove service duplication with Line 66 west of Atlantic Bl/Telegraph Rd to downtown LA. •New connection to East LA College will be created •Discontinue existing Line 62 on Imperial Hwy/Bloomfield Av at Norwalk, reducing overlap of Norwalk Transit service, providing better service on Pioneer Bl. •Discontinue existing Line 62 south of Los Cerritos Center due to underutilized service, with nearest alternative lines available on Long Beach Transit Lines 173 and Cerritos on Wheels	16	33	25	60	60	-	-	-	-	-	-	-	60	35	30	60	60	-	-	-	-	-	-	-	60	60	60	60	60	-	-	-	-	-	-	-
R262		-	-	-	-	-	-	20	20	20	30	60	-	-	-	-	-	-	-	60	30	30	60	60	-	-	-	-	-	-	-	60	30	30	60	60	-
R66	Line 66 between Red Line Wilshire/Western Station and Metrolink Montebello Station via Western Av, 8th St, and Olympic Bl will change as follows: •Replace the deviation along 8th St in East LA with Line 66 traveling direct on Olympic Bl, replacing Line 62 and providing faster more direct service. •Line 605 would still be available on 8th St. •Discontinue service between Olympic & Gerhart and Metrolink Montebello Station due to underutilized service and to reduce overlap of lines, with Line 66 ending at Commerce Center. •Line 18 would provide alternative service to Metrolink Montebello Station	6	20	15	20	60	-	10	10	10	15	30	-	8.5	15	15	30	60	-	15	15	15	15	30	-	22	20	20	30	60	-	15	15	15	15	30	-
R68	New Frequent Line 70 replaces Line 68 between downtown LA and East LA College via Cesar E Chavez Av (see Line 70 information sheet): •Discontinue existing segment of Line 68 east of Atlantic Bl due to underutilized service. •Access to The Shops at Montebello would be available through a connection between Metro Line 18 and Montebello Bus Line 70 at Whittier Bl and Garfield Av	15	20	15	30	45	-	-	-	-	-	-	-	20	20	20	30	40	-	-	-	-	-	-	-	30	20	15	25	45	-	-	-	-	-	-	-
R770		12	15	12	30	-	-	-	-	-	-	-	-	20	22	22	-	-	-	-	-	-	-	-	-	-	-	-	-	-	-	-	-	-	-	-	-
R70	New Higher Frequency Line 70: Merge Lines 70 and 770 New Line 70 would operate between downtown LA and El Monte Station via Garvey Av. The route will follow the existing Line 70 route via Garvey Av, Atlantic Bl, and Cesar Chavez Av: •Alternative New Line 106 would Replace Line 70 service on Ramona Bl and Marengo St. •Underutilized bus stops on Garvey Ave, Atlantic Blvd, and Cesar Chavez Ave would be consolidated to balance speed, reliability and accessibility. •New Overnight Owl service on Cesar Chavez Ave	12	15	12	25	60	60	7.5	7.5	7.5	10	30	60	15	20	15	30	60	60	10	10	10	15	30	60	15	15	15	35	60	60	10	10	10	15	30	60
R71		15	35	35	60	-	-	-	-	-	-	-	-	60	60	60	60	-	-	-	-	-	-	-	-	60	60	60	60	-	-	-	-	-	-	-	-
Garvey/Cesar Chavez		6	7.5	6	15	60	60	7.5	7.5	7.5	10	30	60	10	10	10	30	60	60	10	10	10	15	30	60	15	15	15	30	60	60	10	10	10	15	30	60
R76	Line 76 between downtown LA and El Monte Bus Station via Main St and Valley Blvd would continue to follow the majority of the existing alignment operating more frequent midday and evening service during the weekdays: •Line 76 would no longer travel to the Metrolink El Monte Station due to underutilized service and will instead operate on Santa Anita Av. The Metrolink El Monte Station would be served by City of El Monte's shuttle & trolley services •Line 76 in downtown LA would continue operating on Alameda St. to 1st St. then existing route to 7th St./Maple St.	12	15	12	45	60	60	12	12	12	15	60	60	20	20	15	35	60	60	20	20	20	30	60	60	30	20	20	45	60	60	20	20	20	30	60	60
R78	New Frequent Line 78: Merge Lines 78, 79, and 378 between downtown LA and Arcadia. Route would follow Mission Rd, Huntington Dr then continue along Main St/Las Tunas Dr, Baldwin, back to Huntington Dr with a new connection to Gold Line Arcadia Station •Discontinue Line 78 service on Live Oak Av east of Baldwin Av •Discontinue Line 79 service on Huntington Dr east of Maycrest Av to Baldwin Av due to underutilized service. •Foothill Transit Line 187 would provide alternative service on Huntington Dr at Rosemead Bl to the Gold Line Arcadia Station •Underutilized bus stops would be consolidated to balance speed, reliability, accessibility.	20	15	15	45	60	-	20	20	20	20	30	-	20	15	12	45	60	-	20	20	20	30	60	-	40	32	18	60	60	-	20	20	20	30	60	-
R578		-	-	-	-	-	-	20	20	20	-	-	-	-	-	-	-	-	-	-	-	-	-	-	-	-	-	-	-	-	-	-	-	-	-	-	-
R378		20	-	20	-	-	-	-	-	-	-	-	-	-	-	-	-	-	-	-	-	-	-	-	-	-	-	-	-	-	-	-	-	-	-	-	-
R79		22	40	30	60	60	-	-	-	-	-	-	-	45	45	40	40	60	-	-	-	-	-	-	-	45	32	40	40	60	-	-	-	-	-	-	-
Mission/Las Tunas	7	10	7	24	30	-	10	10	10	20	30	-	12	12	9	15	30	-	20	20	20	30	60	-	22	16	13	24	30	-	20	20	20	30	60	-	

Line	Service Change Proposal	Existing Weekday Frequency						Proposed Weekday Frequency						Existing Saturday Frequency						Proposed Saturday Frequency						Existing Sunday Frequency						Proposed Sunday Frequency					
		AM Peak	Midday	PM Peak	Evening	Late Night	Owl	AM Peak	Midday	PM Peak	Evening	Late Night	Owl	AM Peak	Midday	PM Peak	Evening	Late Night	Owl	AM Peak	Midday	PM Peak	Evening	Late Night	Owl	AM Peak	Midday	PM Peak	Evening	Late Night	Owl	AM Peak	Midday	PM Peak	Evening	Late Night	Owl
		R81	Line 81 route would remain same south of Figueroa St and Yosemite Dr between Harbor Freeway Silver/Green Line Station, downtown LA, and Eagle Rock. Line 81 will replace Line 181 and will be rerouted via Yosemite St to provide service to Colorado Bl/Eagle Rock.	8	15	10	35	60	-	20	20	20	30	60	60	20	20	15	30	60	-	20	20	20	20	30	60	25	25	22	30	60	-	20	20	20	20
RS81	•More frequency during midday hours on weekdays	-	-	-	-	-	-	20	20	20	30	60	60	-	-	-	-	-	-	-	-	-	-	-	-	-	-	-	-	-	-	-	-	-	-	-	-
Figueroa	•Selected trips would continue to end at Figueroa/Colorado •New Overnight Owl Service (in place of Line 83) to Figueroa/Colorado, connecting with Line 180 Overnight Owl service	8	15	10	35	60	-	10	10	10	15	30	30	20	20	15	30	60	-	20	20	20	20	30	60	25	25	22	30	60	-	20	20	20	20	30	60
R83	Line 83 would be replaced with new Line 182 between downtown LA and Eagle Rock via York Blvd and Pasadena Ave and would be extended to East Hollywood (Red Line Vermont/Sunset Station) via York St, Eagle Rock Bl, Fletcher Dr, Rowena Av, and Franklin St: •This new segment provides a more direct east-west connection between Northeast LA and Hollywood while maintaining service to John Marshall High School, and replacing Line 175	23	40	25	40	-	-	-	-	-	-	-	-	35	40	40	40	-	-	-	-	-	-	-	-	34	40	35	40	-	-	-	-	-	-	-	-
R182	•New Line 182 would begin from Lincoln/Cypress Gold Line Station (rather than Downtown LA) via Pasadena Ave and Figueroa St rather than Marmion Wy and Monte Vista St •Frequent alternative service to/from downtown LA is available on Figueroa St (Line 81) and the Gold Line •New Line 81 Overnight Owl Service will replace Line 83 Overnight Owl Service.	-	-	-	-	-	-	30	30	30	30	60	-	-	-	-	-	-	-	60	30	30	30	60	-	-	-	-	-	-	-	60	30	30	30	60	-
R290	New Line 290: Merge Lines 90 & 91 on Foothill Blvd: •New Line 290 would connect with Gold Line Lincoln/Cypress Station for frequent rail connections to downtown LA then extend via Daly St to LA County USC Medical Center	-	-	-	-	-	-	20	20	20	30	60	-	-	-	-	-	-	-	30	30	30	60	60	-	-	-	-	-	-	-	30	30	30	60	60	-
R90	•Line 94 will provide service on Hill St	25	40	30	60	60	-	-	-	-	-	-	-	60	60	60	60	60	-	-	-	-	-	-	-	60	60	60	60	60	-	-	-	-	-	-	-
R91	•On the north end, new Line 290 would be routed on Vineland Av from Sunland to North Hollywood Station, for better connections to bus and rail service	28	30	30	60	60	-	-	-	-	-	-	-	60	60	60	60	60	-	-	-	-	-	-	-	60	60	60	60	60	-	-	-	-	-	-	-
Foothill Blvd	•Line 90 north of Sunland Bl would be discontinued. And new Line 690 would operate on a segment of Foothill Bl between Lake View Terrace and Sylmar	13	18	15	30	30	-	20	20	20	30	60	-	30	30	30	30	30	-	30	30	30	60	60	-	30	30	30	30	30	-	30	30	30	60	60	-
R92	Line 92 will be extended south to Venice & Broadway in downtown LA and operate more frequency.	25	25	25	35	60	60	20	20	20	30	60	-	30	30	30	60	60	60	30	30	30	30	60	60	40	40	40	60	60	60	30	30	30	30	60	60
R292		35	45	35	40	60	-	-	-	-	-	-	-	45	45	45	45	-	-	-	-	-	-	-	-	40	40	40	40	60	-	-	-	-	-	-	-
Glenoaks		25	25	25	35	60	60	20	20	20	30	60	-	30	30	30	60	60	60	30	30	30	30	60	60	40	40	40	60	60	60	30	30	30	30	60	60
R94	New Lines 94 and 794: Merge Lines 94 and 794 on San Fernando Rd: •New Line 94 would operate via the existing Line 94 route between downtown LA and downtown Burbank, then extend west on Magnolia Blvd to end at the Red Line North Hollywood Station. This new route would provide more service between Burbank and North Hollywood.	20	30	25	35	60	-	15	15	15	30	60	60	20	22	20	30	60	-	30	30	30	30	60	60	30	20	20	30	60	-	30	30	30	30	60	60
R294	•A new Line 294 would operate along San Fernando Rd between Sylmar and downtown Burbank. (See New Line 294 information sheet.)	-	-	-	-	-	-	30	30	30	30	60	-	-	-	-	-	-	-	30	30	30	30	60	-	-	-	-	-	-	-	30	30	30	30	60	-
R794	•Underutilized bus stops on new Line 294 would be consolidated between North Hollywood and downtown LA to balance speed, reliability, and accessibility	20	30	20	60	-	-	-	-	-	-	-	-	-	-	-	-	-	-	-	-	-	-	-	-	-	-	-	-	-	-	-	-	-	-	-	-
San Fernando	•Frequent service would be available at all new Line 94 bus stops	10	15	12	20	60	-	15	15	15	30	60	60	-	-	-	-	-	-	30	30	30	30	60	60	-	-	-	-	-	-	30	30	30	30	60	60
R96	Line 96 is will be replaced by the following service: •Lines 92 and 94 would provide service between Burbank, Glendale, and downtown LA •Line 501 between North Hollywood, Burbank, Glendale, and Pasadena would include a new stop at the LA Zoo, with connections to downtown LA available on Brand Bl at Glendale with Line 92. San Fernando Valley residents would have more frequent service to LA Zoo and Griffith Park with direct connections to the Red Line and Orange Line. •Lines 81 and 94 would operate on Hill St to serve Chinatown •Line 92 would serve Echo Park at Glendale Bl Refer to Line 81, Line 92, Line 94, and Line 501 information pages.	28	40	30	55	-	-	-	-	-	-	-	-	50	55	52	55	-	-	-	-	-	-	-	-	60	60	60	60	-	-	-	-	-	-	-	-
R102	New Line 102 would operate between Slauson/Atlantic and Crenshaw/43rd: •Service would be discontinued on Stocker St due to underutilized service, with alternative service on Crenshaw Bl (Line 210), La Brea Av (Line 212) and on La Tijera Bl (with alternative service Slauson Av (Line 108), Centinela Av (Line 110) or Manchester Ave (Line 115)) •Future Crenshaw/LAX light rail service would also connect to LAX area •Reroute Line 102 east of Central Av/41st St to Vernon and Maywood (Slauson/Atlantic) via Central Ave, Vernon Av, Pacific Av, Leonis Bl, District Bl, Atlantic Bl, replacing Line 611 •Line 102 to South Gate via Hooper Av, Gage Av, Central Av, Florence Av, Seville Av would be discontinued due to underutilized service, with alternative service available on Lines 53, 111, 251	34	60	35	55	60	-	30	30	30	30	60	-	30	60	30	60	60	-	30	30	30	30	60	-	30	60	30	60	60	-	30	30	30	30	60	-
R105	New High Frequency Line 105: Merge Lines 105 & 705 on Vernon Av, Martin Luther King, Jr. Bl, and La Cienega Bl between Vernon and West Hollywood: •All New Line 105 trips would continue to serve Santa Rosalia Dr between Hillcrest Dr and Marilton Av	12	18	15	30	60	60	10	10	10	15	30	60	15	15	13	25	60	60	15	15	15	30	30	60	25	16	16	35	60	60	15	15	15	30	30	60
R705	•Discontinue Line 705 segment on Martin Luther King Jr. Bl between Hillcrest Dr and Marilton Av	12	30	15	60	-	-	-	-	-	-	-	-	-	-	-	-	-	-	-	-	-	-	-	-	-	-	-	-	-	-	-	-	-	-	-	-
Vernon	•High frequency service would be provided for all new Line 105 stops •Underutilized bus stops would be consolidated to balance speed, reliability and accessibility.	6	12	7.5	20	60	60	10	10	10	15	30	60	15	15	13	25	60	60	15	15	15	30	30	60	25	16	16	35	60	60	15	15	15	30	30	60
R106	Line 106 between East LA College and LA County USC Medical Center via East LA and Boyle Heights is significantly upgraded: •New Line 106 would extend south via Atlantic Bl to Gold Line Atlantic Station •New Line 106 would replace Line 71 and extend east via Marengo St, Wabash St, City Terrace Dr to Cal State University LA. •New Line 106 would travel direct via 1st St instead of deviating via Indiana St, 3rd St, 4th St (Line 605 and Montebello Bus Lines 40), Soto St (Line 251), Whittier Bl (line 18) and Boyle Av •New Line 106 would operate very frequent service and implement new weekend service. •Underutilized bus stops would be consolidated to balance speed, reliability and accessibility.	50	50	50	50	-	-	15	15	15	30	60	-	-	-	-	-	-	-	30	15	15	30	60	-	-	-	-	-	-	-	30	15	15	30	60	-
R108	New Line 108: Merge Lines 108 & 358 via Slauson Ave between Culver City Transit Center and Pico Rivera: •Discontinue Lines 108 & 358 due to underutilization west of Sepulveda Bl to Marina Del Rey via Jefferson Bl, Centinela Av, Admiralty Way, Via Marina, Pacific Av as well as the deviation into Fox Hills Business Park. Alternative bus service will be available on Culver City Lines 2, 4, 7 and Big Blue Bus Line 18	8	15	9	25	60	-	15	15	15	15	30	60	15	15	15	40	60	-	15	15	15	30	60	60	25	20	20	60	60	-	15	15	15	30	60	60
R358	•New Line 108 would extend east to Slauson/Rosemead to connect with Line 256	15	-	15	-	-	-	-	-	-	-	-	-	-	-	-	-	-	-	-	-	-	-	-	-	-	-	-	-	-	-	-	-	-	-	-	-
RS108	•More frequency at all bus stops on Slauson Av and provide Overnight Owl service	-	-	-	-	-	-	15	15	15	-	-	-	-	-	-	-	-	-	-	-	-	-	-	-	-	-	-	-	-	-	-	-	-	-	-	-
Slauson	•Underutilized bus stops on Slauson Av would be consolidated to balance speed, reliability, and accessibility	6	15	6	25	60	-	7.5	7.5	7.5	15	30	60	15	15	15	40	60	-	15	15	15	30	60	60	25	20	20	60	60	-	15	15	15	30	60	60
R110	Line 110 will continue to serve the existing route from Playa Vista to Bell Gardens. •At the eastern end at Gage/Garfield, buses would stay on Garfield Av and not serve Foster Bridge Bl, Scout Av, and Florence Pl due to underutilized service. •More frequency during the midday and evening hours on weekdays.	10	20	15	40	60	-	15	15	15	30	60	-	25	20	25	40	60	-	30	30	30	30	60	-	40	35	35	50	60	-	30	30	30	30	60	-
R111	Line 111 will remain unchanged.	10	15	10	20	35	60	15	20	15	15	30	60	15	15	15	30	35	60	15	15	15	30	30	60	17	12	12	35	32	60	15	15	15	30	30	60
RS111	New overnight Owl service to serve the full route between Green Line Norwalk Station and LAX City Bus Center.	-	-	-	-	-	-	15	20	15	-	-	-	-	-	-	-	-	-	-	-	-	-	-	-	-	-	-	-	-	-	-	-	-	-	-	-
Florence		-	-	-	-	-	-	7.5	10	7.5	15	30	60	-	-	-	-	-	-	15	15	15	30	30	60	-	-	-	-	-	-	15	15	15	30	30	60
R115	New Line 115 would provide service from Westchester to Norwalk Station via Manchester Ave and Firestone Bl. Service to Playa del Rey would be discontinued west of Manchester/Sepulveda except selected school term trips, due to underutilized service. New Line 115 would provide new Overnight Owl Service.	10	15	10	35	60	-	12	12	12	15	30	60	22	20	20	35	60	-	20	20	20	30	60	60	30	20	20	45	60	-	20	20	20	30	60	60
R117	Line 117 from LAX City Bus Center to Lakewood Blvd Green Line Station would continue to travel via Century Blvd, Tweedy Blvd, and Imperial Hwy. Near Jordan Downs Housing Complex, Line 117 would be rerouted more directly from 103rd St to Century Blvd between Alameda St and Grape St. Line 117 would offer New Overnight Owl service.	15	20	15	35	60	-	15	15	15	30	60	60	30	25	25	50	60	-	30	30	30	30	60	60	30	30	30	35	60	-	30	30	30	30	60	60

Line	Service Change Proposal	Existing Weekday Frequency						Proposed Weekday Frequency						Existing Saturday Frequency						Proposed Saturday Frequency						Existing Sunday Frequency						Proposed Sunday Frequency									
		AM Peak	Midday	PM Peak	Evening	Late Night	Owl	AM Peak	Midday	PM Peak	Evening	Late Night	Owl	AM Peak	Midday	PM Peak	Evening	Late Night	Owl	AM Peak	Midday	PM Peak	Evening	Late Night	Owl	AM Peak	Midday	PM Peak	Evening	Late Night	Owl	AM Peak	Midday	PM Peak	Evening	Late Night	Owl				
R120	New Line 120 would provide service from Aviation/LAX Green Line Station to Green Line Norwalk Station via Imperial Hwy. Shortening Line 120 would allow it to operate more reliably.	40	30	30	45	60	-	30	30	30	30	60	-	55	60	60	60	60	60	-	60	60	60	60	60	60	-	55	60	60	60	60	60	-	60	60	60	60	60	60	-
R621	New Line 621 would replace Line 120 east from Norwalk Green Line Station to Whittwood Mall. In Downey, new Line 120 would remain on Imperial Hwy and not deviate into the Leeds St parking lot at the Rancho Los Amigos National Rehabilitation Center, this will provide faster more direct service.	-	-	-	-	-	-	60	60	60	60	-	-	-	-	-	-	-	-	-	60	60	60	60	-	-	-	-	-	-	-	-	-	60	60	60	60	-	-		
Imperial	Alternative bus service to the Leeds St parking lot remains available via Willowbrook/Rosa Parks Shuttle and Access Services.	-	-	-	-	-	-	30	30	30	30	60	-	-	-	-	-	-	-	-	60	60	60	60	60	-	-	-	-	-	-	-	-	60	60	60	60	60	-		
R125	Line 125 would continue to operate between Norwalk Green Line Station and El Segundo via Rosecrans Ave. Line 125 would offer new Overnight Owl Service. Line 126 would be discontinued due to underutilized service.	14	35	25	60	-	-	20	20	20	30	60	60	40	30	30	60	-	-	30	30	30	30	60	60	60	30	40	60	-	-	30	30	30	30	60	60				
R126	Nearest alternative services would be available as follows: •Torrance Transit Line 8 (Aviation Bl) •Beach Cities Transit Line 109 •LADOT Commuter Express 438 (Highland Av) •Metro Lines 125 (Rosecrans Av) •Metro Line 210 (Crenshaw Bl) •Metro Line 212 (Hawthorne Bl) •Metro Line 232 (Sepulveda Bl) •G-Trans Line 5 (El Segundo Bl)	35	-	70	-	-	-	-	-	-	-	-	-	-	-	-	-	-	-	-	-	-	-	-	-	-	-	-	-	-	-	-	-	-	-	-	-				
R127	New Line 127 would follow the existing Line 127 route between A Line (Blue) Compton Station and Downey Depot, except for remaining on Somerset Blvd between Clark Av and Bellflower Bl.	60	60	60	-	-	-	30	30	30	30	60	-	-	-	-	-	-	-	60	60	60	60	60	60	-	-	-	-	-	-	60	60	60	60	60	60				
RS127	Service will be discontinued on Alondra Bl due to underutilized service in that segment and to make the route more direct. New Line 127 would be extended west of the A Line (Blue) Compton Station to the Harbor Freeway Station via Compton Bl, San Pedro St, El Segundo Bl, and Broadway to Figueroa/117th St, replacing a segment of Line 45 and existing Line 51.	-	-	-	-	-	-	30	30	30	-	-	-	-	60	60	-	-	-	-	60	60	-	-	-	-	60	60	-	-	-	-	60	60	-	-	-				
Compton	New weekend service and more frequent weekday service would be provided.	-	-	-	-	-	-	15	15	15	30	60	-	-	-	-	-	-	-	60	30	30	60	60	60	-	-	-	-	-	-	60	30	30	60	60	60				
R128	Line 128 between A Line (Blue) Compton Station and Cerritos Towne Center via Alondra Bl will change as follows: •Existing Line 128 segment south of Alondra Bl & Carnerita Rd will be discontinued due to underutilized service. •Alternative service to Cerritos Towne Center available via Cerritos On Wheels (COW) Route 1-A	35	55	55	60	-	-	60	60	60	60	-	-	-	-	-	-	-	-	60	60	60	60	-	-	-	-	-	-	-	-	60	60	60	60	-	-				
R130	Line 130 would continue to operate on Artesia Bl between the A (Blue) Line Artesia Station and Cerritos with new Overnight Owl service provided to improve late night and early morning trips. This segment of Line 130 would be operated initially by Metro and later transitioned to be operated by Long Beach Transit.	25	50	30	55	-	-	30	30	30	30	60	60	60	60	60	60	-	-	60	60	60	60	60	60	60	60	60	60	-	-	60	60	60	60	60	60				
R344	Line 130 west of the Artesia A (Blue) Line Station would transition to be operated by Torrance Transit as their new Line 13, following its existing route via Artesia Bl to Redondo Beach. Line 344 would operate via the existing route and stops via Artesia Bl and Hawthorne Bl to a new southern terminus at Hawthorne/Silver Spur. Service would be discontinued south of Silver Spur Rd to Rancho Palos Verdes due to underutilized service. Select alternative service is available by Palos Verde Peninsula Transit Authority.	20	60	20	60	-	-	30	30	30	30	30	-	35	40	40	60	-	-	60	60	60	60	60	60	60	60	60	60	-	-	60	60	60	60	60	60				
R150	New Lines 150 and 240: Merge Lines 150, 240 and 750: •New Line 150 would operate frequent service from Ventura/Reseda west to Chatsworth Station along Ventura Bl and Topanga Canyon Bl (replacing Line 245 segment) •New Line 240 would operate frequent service on the existing alignment between Northridge and Universal City/Studio City Station on Ventura Bl and Reseda Bl	20	22	24	40	60	60	20	20	20	30	60	-	20	30	30	40	40	60	30	30	30	30	60	60	30	35	35	40	40	60	30	30	30	30	60	60				
R750	•More frequent service at all new Line 150 and 240 bus stops •Underutilized bus stops would be consolidated on new Line 150 and 240 to balance speed, reliability, and accessibility.	15	30	15	30	-	-	-	-	-	-	-	-	-	-	-	-	-	-	-	-	-	-	-	-	-	-	-	-	-	-	-	-	-	-	-	-				
R240	•More frequent service at all new Line 150 and 240 bus stops •Underutilized bus stops would be consolidated on new Line 150 and 240 to balance speed, reliability, and accessibility.	25	32	24	40	40	60	10	10	10	15	30	60	30	20	10	35	40	60	15	15	15	15	30	60	30	35	35	40	40	60	15	15	15	15	30	60				
Reseda/Ventura		7.5	9	7	12	24	30	10	10	10	15	30	60	12	12	7.5	20	20	30	15	15	15	15	30	60	15	17	17	20	20	30	15	15	15	15	30	60				
R152	Line 152: Merge Lines 152 & 353: •New Line 152 would continue to serve Roscoe Bl with proposed frequency improvements midday weekdays •On the east end, new Line 152 is proposed to travel via Lankershim Bl to provide a more direct connection to the Red Line North Hollywood Station.	20	25	25	35	60	-	15	15	15	30	60	60	25	25	25	60	60	-	30	20	20	30	60	60	35	30	30	60	60	-	30	20	20	30	60	60				
R353	•Service on Vineland Ave would be provided by modified Lines 162 and new Line 290 (please see Line 162 and Line 290 information sheets) •The route is proposed to terminate at Topanga Canyon Bl in the west end. A modified Line 162 would provide service on Fallbrook Av	20	-	25	-	-	-	-	-	-	-	-	-	-	-	-	-	-	-	-	-	-	-	-	-	-	-	-	-	-	-	-	-	-	-	-	-				
Roscoe		10	25	13	35	60	-	15	15	15	30	60	60	25	25	25	60	60	-	30	20	20	30	60	60	35	30	30	60	60	-	30	20	20	30	60	60				
R153	New Line 153 would operate between the Red Line North Hollywood Station and downtown Burbank via Burbank Bl, as well as an existing segment of Burbank Bl east of the Red Line North Hollywood Station.	-	-	-	-	-	-	30	30	30	30	30	-	-	-	-	-	-	-	60	30	30	30	60	-	-	-	-	-	-	-	60	30	30	30	60	-				
R154	Line 154 would operate between the Red Line North Hollywood Station and Sepulveda Bl, via Oxnard St and Burbank Bl as a two-way direction circulator: •More frequency on the new proposed route •Discontinue service west of Sepulveda Bl due to underutilized service	60	65	64	-	-	-	30	30	30	30	-	-	-	-	-	-	-	-	60	60	60	60	-	-	-	-	-	-	-	-	60	60	60	60	-	-				
R155	New Line 155 will merge existing Line 155 with a segment of Line 183: •New Line 155 would operate via Riverside Dr, Sepulveda Bl, and Magnolia Bl between the Red Line North Hollywood Station and Red Line Universal City/Studio City Station •Segment of Line 155 east of Universal City/Studio City Station via Olive Ave would continue to be served by Burbank Bus newly improved Pink Route	42	45	45	60	-	-	30	30	30	30	-	-	50	50	50	50	-	-	60	60	60	60	-	-	60	60	60	60	-	-	60	60	60	60	-	-				
R158	New Line 158 would follow the existing Line 158 via Woodman Av, then travel via Plummer St to Chatsworth Station, while new Line 167 would serve the current Line 158 segment on Devonshire St. •This swap of east-west alignments between Lines 158 and 167 is intended to create simpler, easier to use Lines 158 and 167 •Service to Sepulveda Ambulatory Care Center would be provided on-street at Haskell Av and Gloria Av	22	60	50	60	-	-	60	60	60	60	-	-	60	60	60	60	-	-	60	60	60	60	-	-	60	50	50	55	-	-	60	60	60	60	-	-				
R161	Line 161 would operate primarily on the existing route between Orange Line Canoga Station and City of Thousand Oaks: •In Calabasas, Line 161 would operate on Calabasas Rd instead of Park Calabasas and Park Granada to improve travel time	20	60	35	55	-	-	60	60	30	60	-	-	60	60	60	60	-	-	60	60	60	60	-	-	60	65	65	60	-	-	60	60	60	60	-	-				
R162	New Line 162: Merge Line 162 & Line 163: •More frequency during the mid-day on weekdays on Sherman Way •On the east end, new Line 162 would be routed via Vineland Av to provide more service along that corridor while still connecting to Red Line North Hollywood Station	20	40	20	50	60	-	15	15	15	20	30	60	50	60	60	60	60	-	30	30	30	30	30	60	50	60	60	-	-	30	30	30	30	30	60					
R163	•Line 152 would serve Lankershim Bl. (see Line 152 information sheet) •New Line 162 would be extended to serve Fallbrook Av in the west end •Line 169 would continue to directly serve West Hills Medical Center (see Line 169 information sheet)	20	40	30	60	60	-	-	-	-	-	-	-	50	60	60	60	60	-	-	-	-	-	-	-	50	60	60	60	60	-	-	-	-	-	-	-				
Sherman Way		10	20	12	30	30	-	15	15	15	20	30	60	25	30	30	30	30	30	30	30	30	30	60	25	30	30	60	60	30	30	30	30	30	60						
R164	Line 164 would operate in partnership with Line 165, with buses changing between each Line at Platt Ave/Victory Bd (to eliminate a long turn-around loop and reinvest into more frequent service). Line 164 would operate more frequency during the midday hours on weekdays.	12	30	15	35	60	-	15	15	15	30	60	-	30	30	30	40	60	-	30	30	30	30	30	60	-	35	35	30	60	60	-	30	30	30	30	60	60			
R165	Line 165 would operate in partnership with Line 164, with buses changing between each Line at Platt Ave/Victory Bd (to eliminate a long turn-around loop and reinvest into more frequent service).	6.5	30	10	30	60	-	15	15	15	30	60	-	40	35	35	60	60	-	30	30	30	30	60	-	40	40	40	40	60	-	30	30	30	30	60	60				
R166	New Line 166: Merge Lines 166 & 364: •Would continue to serve Nordhoff St and Osborne St •Would operate more frequent midday weekday service •New Line 166 would extend east via Osborne St and Foothill Bl to Hansen Dam and Discovery Cube, making connections with New Line 690 on Foothill Bl •A short segment of Glenoaks Bl would then be served by Line 92	15	24	15	40	60	-	15	15	15	30	60	60	35	35	35	60	-	-	30	30	30	30	60	60	40	40	40	40	-	-	30	30	30	30	60	60				
R364		15	-	15	-	60	-	-	-	-	-	-	-	-	-	-	-	-	-	-	-	-	-	-	-	-	-	-	-	-	-	-	-	-	-	-	-				

Line	Service Change Proposal	Existing Weekday Frequency						Proposed Weekday Frequency						Existing Saturday Frequency						Proposed Saturday Frequency						Existing Sunday Frequency						Proposed Sunday Frequency					
		AM Peak	Midday	PM Peak	Evening	Late Night	Owl	AM Peak	Midday	PM Peak	Evening	Late Night	Owl	AM Peak	Midday	PM Peak	Evening	Late Night	Owl	AM Peak	Midday	PM Peak	Evening	Late Night	Owl	AM Peak	Midday	PM Peak	Evening	Late Night	Owl	AM Peak	Midday	PM Peak	Evening	Late Night	Owl
Nordhoff	<ul style="list-style-type: none"> On the west end, New Line 166 is proposed to end at Nordhoff St/Canoga Av, with access to Chatsworth Station via the Metro Orange Line A segment on Topanga Canyon Blvd would continue to be served by new Line 150 New Line 158 would follow the existing Line 158 via Woodman Av, then travel via Plummer St to Chatsworth Station, while new Line 167 would serve the current Line 158 segment on Devonshire St. This swap of east-west alignments between Lines 158 and 167 is intended to create simpler, easier to use Lines 158 and 167 Service to Sepulveda Ambulatory Care Center would be provided on-street at Haskell Av and Gloria Av 	7.5	24	7.5	40	60	-	15	15	15	30	60	60	35	35	35	60	-	30	30	30	30	60	60	40	40	40	40	-	30	30	30	30	60	60		
R167	<ul style="list-style-type: none"> New Line 169 would operate on Satcoy St between Lankershim Bl and West Hills Medical Center. The east end of new Line 169 would end at Satcoy St/Lankershim Bl due to underutilized service east of Lankershim Bl. Discontinue the segment south of West Hills Medical Center due to underutilized service Additional trips serving El Camino High School would be maintained More weekday frequency and new weekend service would be provided between Lankershim Bl and Fallbrook Av 	40	40	55	60	60	-	60	60	60	60	60	-	50	40	60	60	60	-	60	60	60	60	60	-	50	40	60	60	60	-	60	60	60	60	60	-
R169	<ul style="list-style-type: none"> New Line 169 would operate on Satcoy St between Lankershim Bl and West Hills Medical Center. The east end of new Line 169 would end at Satcoy St/Lankershim Bl due to underutilized service east of Lankershim Bl. Discontinue the segment south of West Hills Medical Center due to underutilized service Additional trips serving El Camino High School would be maintained More weekday frequency and new weekend service would be provided between Lankershim Bl and Fallbrook Av 	10	60	25	60	-	-	30	30	30	30	-	-	-	-	-	-	-	-	60	60	60	60	-	-	-	-	-	-	-	-	60	60	60	60	-	-
R175	Replace Line 201 weekday service between Koreatown and Glendale via Silver Lake with frequent service on Fletcher Dr, Rowena Av, and Franklin St (see New Line 83 information sheet), Glendale Bl (Line 92) and Sunset Av (new Lines 2 and 4).	15	-	60	60	-	-	-	-	-	-	-	-	-	-	-	-	-	-	-	-	-	-	-	-	-	-	-	-	-	-	-	-	-	-	-	-
R201	Discontinue Line 176 weekday service between Highland Park and El Monte Bus Station due to underutilized service and overlap of Metro Lines 78, 258, 260, 266 and 267, Montebello Bus Lines 20 and 30, and Foothill Transit Line 487.	55	55	54	54	-	-	-	-	-	-	-	-	60	70	70	66	-	-	-	-	-	-	-	55	70	70	66	-	-	-	-	-	-	-		
R176	Discontinue Line 176 weekday service between Highland Park and El Monte Bus Station due to underutilized service and overlap of Metro Lines 78, 258, 260, 266 and 267, Montebello Bus Lines 20 and 30, and Foothill Transit Line 487.	40	45	45	50	-	-	-	-	-	-	-	-	-	-	-	-	-	-	-	-	-	-	-	-	-	-	-	-	-	-	-	-	-	-	-	-
R177	Pasadena Transit would operate weekday peak period service between Pasadena and the Jet Propulsion Laboratory in place of Metro, with a minor reroute proposed in Pasadena to use Mountain St instead of Walnut St.	30	-	30	60	-	-	-	-	-	-	-	-	-	-	-	-	-	-	-	-	-	-	-	-	-	-	-	-	-	-	-	-	-	-	-	-
R180	New Frequent Line 180: Merge Lines 180, 181, 217, 780	30	60	30	50	60	60	7.5	7.5	7.5	10	30	60	24	36	24	40	-	15	15	15	15	60	60	50	24	24	50	-	15	15	15	15	60	60		
R181	New Line 180 would operate between Pasadena, Glendale, Hollywood via Colorado Bl, Broadway, Los Feliz Bl, Hollywood Bl, Fairfax Av, following existing Lines 217, 180, 181 between La Cienega/Jefferson Expo Line Station and Pasadena City College.	30	60	30	50	60	-	-	-	-	-	-	-	36	36	36	40	-	-	-	-	-	-	-	50	36	36	50	-	-	-	-	-	-	-		
R780	Underutilized bus stops on new Line 180 would be consolidated to balance speed, reliability, and accessibility	10	20	12	60	-	-	-	-	-	-	-	-	-	-	-	-	-	-	-	-	-	-	-	-	-	-	-	-	-	-	-	-	-	-	-	-
R217	Discontinue Line 217 south of La Cienega/Jefferson Station to Westfield Culver City due to underutilized service	15	15	13	15	30	60	-	-	-	-	-	-	40	15	12	20	30	60	-	-	-	-	-	-	35	20	15	20	30	60	-	-	-	-	-	-
Colorado/Fairfax	<ul style="list-style-type: none"> Pasadena Transit Line 20 and New Line 662 would replace Line 180 on Lake Av Foothill Transit Line 187 would replace Line 181 service on Colorado Bl east of Pasadena City College 	6	7	9	9	30	60	7.5	7.5	7.5	10	30	60	12	18	12	20	-	15	15	15	15	60	60	25	12	12	25	-	15	15	15	15	60	60		
R183	<ul style="list-style-type: none"> Merge Line 183 with a segment of Line 155: New Line 155 would operate via Riverside Dr, Sepulveda Bl, and Magnolia Bl between North Hollywood Station and Universal City/Studio City Station New Line 94 would provide more frequency on the segment of existing Line 183 east of Red Line North Hollywood Station along Magnolia Bl 	30	60	30	60	-	-	30	30	30	30	-	-	65	65	65	65	-	60	60	60	60	-	-	65	65	65	65	-	60	60	60	60	-	-		
R202	<ul style="list-style-type: none"> New Line 202 would operate peak hours only weekdays via the existing Line 202 route between A (Blue) and Green Line and Imperial/Wilmington Rosa Parks Stations' to A Line (blue) Artesia Station. Discontinue service south of A Line (Blue) Artesia Station to Wilmington via Santa Fe Av, Victoria St, Susana Rd, Del Amo Bl and Alameda St due to underutilized service. Nearest alternative Metro service would be Line 205 (Wilmington Av), Line 232 (Anaheim St) and Line 246 (Avalon Bl). 	60	-	60	-	-	-	30	-	30	-	-	-	-	-	-	-	-	-	-	-	-	-	-	-	-	-	-	-	-	-	-	-	-	-	-	-
R204	New Line 204 would follow the existing route between Hollywood and the Green Line Vermont/Athens Station via Vermont Av.	10	15	10	20	30	30	5	5	5	10	15	30	20	20	15	20	30	30	7.5	7.5	7.5	10	15	30	20	20	15	20	30	30	7.5	7.5	7.5	10	15	30
R54	<ul style="list-style-type: none"> New Line R54 would provide more frequent midday and weekend service New Line R54 would provide more weekday peak service serving existing Line 754 stops More frequency would be provided for all New Line 204 bus stops on Vermont Ave Underutilized existing Line 204 bus stops would be consolidated to balance speed, reliability, and accessibility. 	6	15	6	20	-	-	10	-	10	-	-	-	12	12	12	20	-	-	-	-	-	-	-	25	15	20	30	-	-	-	-	-	-	-		
Vermont	<ul style="list-style-type: none"> New Line 204 would provide faster service on a simpler route via Del Amo Bl between Wilmington Bl and Main St, serving new development and connecting with Silver Line service at Carson Transitway Station. This will eliminate out-of-direction service overlapping Line 246 on Avalon Bl to Harbor Gateway Transit Center Avoids service duplication of Torrance Transit Line 6 on Victoria St and Torrance Transit Line 1 on Vermont Av north of Carson St In San Pedro, new Line 205 would be simpler, serving 7th Street in both directions between Harbor Bl and Weymouth Av, and alternative service on 1st St and 13th St would be provided by DASH San Pedro 	4	7.5	4	10	30	30	5	5	5	10	15	30	7.5	7.5	7	10	30	30	7.5	7.5	7.5	10	15	30	12	8	8	12	30	30	7.5	7.5	7.5	10	15	30
R205	<ul style="list-style-type: none"> Line 206 will continue to serve Normandie Av between Red Line Vermont/Sunset Station and Green Line Vermont/Athens Station, with no proposed route changes, and more frequency during the midday hours on weekdays. 	25	30	35	50	60	-	30	30	30	30	60	-	50	55	60	60	60	-	60	60	60	60	-	-	55	60	60	60	60	-	60	60	60	60	-	-
R206	Line 206 will continue to serve Normandie Av between Red Line Vermont/Sunset Station and Green Line Vermont/Athens Station, with no proposed route changes, and more frequency during the midday hours on weekdays.	8	20	12	20	60	-	10	15	10	15	30	-	20	20	20	30	60	-	20	20	20	20	30	-	20	20	20	30	60	-	20	20	20	20	30	-
R207	New High Frequency Line 207: Merge Lines 207 and 757	10	15	10	20	20	60	6	7.5	6	12	15	30	12	12	10	15	20	60	12	12	12	15	15	30	15	12	12	20	35	60	12	12	12	15	15	30
R757	New Line 207 would operate between Hollywood and the Green Line Crenshaw Station:	10	15	8	-	-	-	-	-	-	-	-	-	-	-	-	-	-	-	-	-	-	-	-	-	-	-	-	-	-	-	-	-	-	-	-	-
Western	<ul style="list-style-type: none"> More frequency for all new Line 207 bus stops on Western Av Underutilized bus stops would be consolidated on Western Av to balance speed, reliability, and accessibility. 	5	7.5	6	20	20	60	6	7.5	6	12	15	30	12	12	10	15	20	60	12	12	12	15	15	30	15	12	12	20	35	60	12	12	12	15	15	30
R209	<ul style="list-style-type: none"> Discontinue Line 209 on Van Ness Ave and Arlington Av due to underutilized service. Alternative service is available on nearby Western Av (Metro Line 207) and Western and Vermont Av (G-Trans Line 2). 	50	60	50	60	-	-	-	-	-	-	-	-	-	-	-	-	-	-	-	-	-	-	-	-	-	-	-	-	-	-	-	-	-	-	-	-
R210	New High Frequency Line 210: Merge Lines 210 & 710	15	20	15	30	60	-	10	10	10	15	30	60	30	20	20	20	60	-	10	10	10	15	30	60	25	15	15	30	60	-	10	10	10	15	30	60
R610	New Line 210 would operate via Crenshaw Bl between Crenshaw/Wilshire and Crenshaw/Redondo Beach and via Redondo Beach Bl to South Bay Galleria:	-	-	-	-	-	-	15	15	15	30	30	-	-	-	-	-	-	15	15	15	30	30	-	-	-	-	-	-	-	15	15	15	30	30	-	
R710	<ul style="list-style-type: none"> More frequency would be provided for all bus stops on Crenshaw Bl. Underutilized bus stops on Crenshaw Bl would be consolidated to balance speed, reliability, and accessibility. Torrance Transit Line 2 would replace the existing Line 210 segment on Crenshaw Bl and Artesia Bl south of El Camino College 	10	20	10	20	-	-	-	-	-	-	-	-	20	20	20	20	-	-	-	-	-	-	-	-	-	-	-	-	-	-	-	-	-	-	-	
Crenshaw	<ul style="list-style-type: none"> New Metro Line 610 would replace existing Line 210 north of Wilshire Bl via Rossmore Av and Vine St to Red Line Hollywood/Vine Station New Line 210 would provide new Late Night Owl service 	6	10	6	12	60	-	10	10	10	15	30	60	12	10	10	10	60	-	10	10	10	15	30	60	25	15	15	30	60	-	10	10	10	15	30	60
R211	<ul style="list-style-type: none"> New Lines 211 and 215 would operate as separate two-directional loop routes serving north (new Line 211) and south (new Line 215) of the Green Line Hawthorne/Lennox Station. Service would provide new midday weekday, night and weekend service on both lines: New Line 211 loop would replace Line 212/312 on Prairie Av (Line 212 would instead serve Hawthorne Bl) and New Line 211 would also replace Line 215 service on Manchester Av and Inglewood Av north of the Green Line New Line 215 loop would replace existing Lines 211 and 215 south of the Green Line on Prairie Av, Marine Av, and Inglewood Av 	30	-	30	-	-	-	30	30	30	30	60	-	-	-	-	-	-	-	60	60	60	60	60	-	-	-	-	-	-	-	60	60	60	60	60	-
R215	<ul style="list-style-type: none"> New Lines 211 and 215 would operate as separate two-directional loop routes serving north (new Line 211) and south (new Line 215) of the Green Line Hawthorne/Lennox Station. Service would provide new midday weekday, night and weekend service on both lines: New Line 211 loop would replace Line 212/312 on Prairie Av (Line 212 would instead serve Hawthorne Bl) and New Line 211 would also replace Line 215 service on Manchester Av and Inglewood Av north of the Green Line New Line 215 loop would replace existing Lines 211 and 215 south of the Green Line on Prairie Av, Marine Av, and Inglewood Av 	30	-	30	-	-	-	30	30	30	30	60	-	-	-	-	-	-	-	60	60	60	60	60	-	-	-	-	-	-	-	60	60	60	60	60	-

Line	Service Change Proposal	Existing Weekday Frequency						Proposed Weekday Frequency						Existing Saturday Frequency						Proposed Saturday Frequency						Existing Sunday Frequency						Proposed Sunday Frequency					
		AM Peak	Midday	PM Peak	Evening	Late Night	Owl	AM Peak	Midday	PM Peak	Evening	Late Night	Owl	AM Peak	Midday	PM Peak	Evening	Late Night	Owl	AM Peak	Midday	PM Peak	Evening	Late Night	Owl	AM Peak	Midday	PM Peak	Evening	Late Night	Owl	AM Peak	Midday	PM Peak	Evening	Late Night	Owl
Soto	underutilized service and duplication of service from other lines. The following alternative bus service would be available: Figueroa St (Line 81); Pasadena Av (new Line 182); Broadway (Line 45); Huntington Dr (Line 78), Valley Bl (Line 76), and Soto St (Line 51).	7.5	10	9	15	50	60	10	10	10	15	30	60	15	12	12	40	50	60	15	15	15	30	30	60	25	15	15	40	50	60	15	15	15	30	30	60
R254	Line 254 would be discontinued between East LA and Watts via Boyle Av and Lorena St due to underutilized service and duplication of service from other lines. The following alternative bus services would be available: 103rd St (Line 117), Compton Av (Line 55); Firestone Bl (Line 115); Florence Av (Line 111); Pacific Bl (Lines 60, 251); Gage Av (Line 110); Lorena Av (Line 605); Indiana St (Line 665).	35	70	70	-	-	-	-	-	-	-	-	-	60	60	60	-	-	-	-	-	-	-	-	-	-	-	-	-	-	-	-	-	-	-	-	-
R256	Line 256 between Commerce and Altadena via El Sereno, Highland Park, and Pasadena would be subdivided by three separate bus lines with more frequent service: •City of Commerce would operate the existing segment between Commerce and Cal State LA Station, with no proposed changes to alignment •Metro would continue to operate the existing segment between Cal State LA Station and Gold Line Highland Park Station as Line 256, with no proposed changes to alignment •Pasadena Transit would operate a simpler route between Highland Park and Pasadena, via Colorado Bl, Gold Line Memorial Park Station, Lincoln Ave, Washington Bl, Altadena Dr and Foothill Bl to Sierra Madre Villa Station •New Line 662 would serve Lake Av between Pasadena and Altadena, with Metro Lines 180, 686 and Foothill Transit 187 serving Colorado Bl in Pasadena	50	50	50	45	-	-	20	30	30	30	30	-	60	60	60	60	-	-	40	40	40	40	-	-	60	60	60	60	-	-	40	40	40	40	-	-
R258	Line 258 would be shortened between Paramount and Altadena via South Gate, Bell Gardens, Commerce, East LA, Monterey Park, Alhambra and Pasadena on Eastern Av, Fremont Av, and Lake Av to improve reliability and avoid duplication of other bus service. This would provide a much-requested connection with the Gold Line South Pasadena Station via Fremont Av and Fair Oaks Av: •Service would be discontinued on Huntington Dr/Oak Knoll Av-Cir in San Marino due to underutilized Line 258 service •New Metro Line 662 would operate two-directional service on Lake Av, Altadena Dr, Lincoln Av, Washington Bl, and Los Robles Av between Pasadena (Gold Line Del Mar and Lake Stations) and Altadena •New Lines 258 and 662 would both provide new weekend service	40	40	40	60	-	-	40	40	40	40	60	-	-	-	-	-	-	-	60	60	60	60	60	-	-	-	-	-	-	-	60	60	60	60	60	-
R260	New Line 260: Merge Lines 260 & 762 between Altadena, Pasadena, Alhambra, East LA, Lynwood and Compton via Fair Oaks Av and Atlantic Bl; would provide more frequent and more reliable service following the existing Line 260/762 route between Gold Line Memorial Park Station and Imperial Highway then travel west to Willowbrook/Rosa Parks A (Blue) & Green Line Station:	15	20	15	20	60	-	12	12	12	15	30	60	20	20	20	40	60	-	20	20	20	30	30	60	30	20	20	30	60	-	20	20	20	30	30	60
R261		-	-	-	-	-	-	15	15	15	15	30	-	-	-	-	-	-	-	30	30	30	30	60	-	-	-	-	-	-	-	30	30	30	30	60	-
R660		-	-	-	-	-	-	15	15	15	15	30	-	-	-	-	-	-	-	15	15	15	15	30	-	-	-	-	-	-	-	15	15	15	15	30	-
R762	•A new frequent Line 261 would link A (Blue) Line & Green Line Willowbrook/Rosa Parks A (Blue) Station and A (Blue) Line Artesia Station via Imperial Hwy, Atlantic Bl, and Artesia Bl •A new frequent Line 660 would operate between Gold Line Memorial Park Station and Altadena via Fair Oaks Av	25	30	25	60	-	-	-	-	-	-	-	-	-	-	-	-	-	-	-	-	-	-	-	-	-	-	-	-	-	-	-	-	-	-	-	-
Atlantic		10	12	10	15	60	-	12	12	12	15	30	60	20	20	20	40	60	-	15	15	15	15	30	60	30	20	20	30	60	-	15	15	15	15	30	60
R264	Line 264 would be discontinued between Duarte, Monrovia, Arcadia, Pasadena, Altadena via Duarte Rd, Michillinda Ave, Foothill Bl, Altadena Dr due to underutilized service and duplication of service of other bus lines: •New Line 256 (Pasadena Transit) would serve Altadena Dr (south of Washington Bl) and Foothill Bl, with new Line 662 serving Altadena Dr at Lake Av •Nearest alternative service in Duarte and Monrovia would be Metro Gold Line, Foothill Transit on Buena Vista St (Line 272) and Myrtle Av (Line 170), and Duarte Transit •Nearest alternative service to Arcadia-Sierra Madre Villa would be on Temple City Bl, Huntington Dr, Rosemead Bl, Michillinda Av (Metro Lines 266, 267, 268 and Foothill Transit Line 187) and on Baldwin Av/Huntington Dr (Metro Lines 78 and 268)	60	60	65	60	-	-	-	-	-	-	-	-	60	60	60	-	-	-	-	-	-	-	-	-	60	60	60	-	-	-	-	-	-	-	-	-
R267	Line 267 would be shortened between El Monte, Arcadia, Pasadena, and Altadena via Temple City Bl, Rosemead Bl, Del Mar Bl, Lincoln Av, and Altadena Dr to end at the Gold Line Del Mar Station in Pasadena. This would improve reliability and avoid service duplication with other bus lines: •Pasadena Transit would operate new Line 256 on southern end of Lincoln Ave with new Metro Line 662 serving the north end of Lincoln Av and Altadena Dr	30	30	30	25	-	-	30	30	30	30	-	-	60	60	60	-	-	-	60	60	60	60	-	-	60	60	60	-	-	-	60	60	60	60	-	-
R265	More frequent service would be provided during daytime hours on weekdays. Line 266 has no significant changes between Lakewood, Bellflower, Downey, Pico Rivera, South El Monte, Arcadia, Pasadena, and Altadena via Lakewood Bl and Rosemead Bl:	40	60	60	60	-	-	30	30	30	30	60	-	-	60	60	60	-	-	60	60	60	60	-	-	-	60	60	60	-	-	60	60	60	60	-	-
R266	•Line 266 would end on northbound Lakewood Bl adjacent to Lakewood Center Mall for improved connections with the mall and Line 265 •Line 266 would provide more frequent service during midday hours on weekdays and weekends	20	35	20	50	-	-	20	20	20	30	60	-	45	45	40	40	40	-	30	30	30	30	60	-	50	45	45	45	-	-	30	30	30	30	60	-
R268	Line 268 route would be shortened between El Monte, Arcadia, Sierra Madre, Pasadena, La Canada Flintridge (Jet Propulsion Lab), and Altadena via Baldwin Av, Sierra Madre Bl, Orange Grove Bl, and Washington Bl to end at the Gold Line Sierra Madre Villa Station to improve reliability and avoid service duplication of other bus lines: •Pasadena Transit would operate new Line 256 on southern end of Lincoln Ave, Washington Blvd, Altadena Dr, Foothill Bl to Sierra Madre Villa Station •New Metro Line 662 would serve the northern end of Lincoln and Washington Blvd west of Los Robles Av (see Line 662 information sheet) •Line 268 has very low utilization to JPL on weekends. Line 177 (to be operated by Pasadena Transit) would provide alternative service to JPL on the weekdays only during peak periods via connections to the Gold Line Del Mar & Memorial Park Stations. •Line 268 would provide more frequent service during midday hours on weekdays and weekends	30	50	30	50	-	-	30	30	30	30	60	-	60	60	50	50	-	-	60	60	60	60	60	-	60	60	60	60	-	-	60	60	60	60	60	-
R442	Express Line 442 would be discontinued due to underutilized service and service duplication with other bus lines. Alternative bus service would be available on Metro Silver Line to Manchester Station (connection with Line 115 on Manchester Bl) or Harbor Freeway Station (connection with Line 120 on Imperial Hwy or Green/Silver Line service).	40	-	40	-	-	-	-	-	-	-	-	-	-	-	-	-	-	-	-	-	-	-	-	-	-	-	-	-	-	-	-	-	-	-	-	-
R460	Line 460 would operate between downtown LA and Disneyland via I-110 Harbor Transitway, I-105, Green Line Norwalk Station, Rosecrans Av, Carmentia Rd, Alondra Bl, Beach Bl, I-5 and Harbor Bl	20	25	25	30	40	-	-	-	-	-	-	-	30	25	25	30	40	-	-	-	-	-	-	-	30	30	30	30	35	-	-	-	-	-	-	-
R160	Line 460 would operate as new Line 160 between Green Line Norwalk Station and Disneyland: •New Line 160 would not serve the existing Line 460 segment between downtown LA and Green Line Norwalk Station due to duplication of other service; alternative bus service for this segment would be available by utilizing the Silver Line, Blue Line and Green Line •New Line 160 would bypass Fullerton Park & Ride to provide faster, more direct service to Knott's Berry Farm in Buena Park and Disneyland in Anaheim, with alternative bus service available on OCTA Routes 30 and Bravo! 529	-	-	-	-	-	-	30	30	30	30	60	-	-	-	-	-	-	-	30	30	30	30	60	-	-	-	-	-	-	-	30	30	30	30	60	-
R487	New Line 487: frequent service would link the Gold Line Sierra Madre Villa Station and LA Union Station via San Gabriel Bl, Las Tunas Dr, Mission Dr, Del Mar Av, I-10 Express-Lanes: •Frequent Metro Red/Purple/Silver Line services would serve downtown LA and Westlake/MacArthur Park in place of Line 487 •New Line 287 would be introduced, serving existing Line 487 segment between El Monte Station and Gold Line Arcadia Station via Santa Anita Ave seven days a week •Existing Line 487 north and west of Gold Line Arcadia Station to Gold Line Sierra Madre Villa Station via Santa Anita Av, Sierra Madre Av, San Gabriel Av would be discontinued due to underutilized service, with alternative Metro Line 268 service available on Baldwin Av, Sierra Madre Bl and Michillinda Av	25	40	40	50	-	-	15	30	15	30	60	-	50	60	50	60	-	-	60	60	60	60	60	-	60	50	50	60	-	-	60	60	60	60	60	-
R287		-	-	-	-	-	-	30	30	30	30	60	-	-	-	-	-	-	-	60	60	60	60	60	-	-	-	-	-	-	-	60	60	60	60	60	-
R489		15	-	20	-	-	-	20	-	20	-	-	-	-	-	-	-	-	-	-	-	-	-	-	-	-	-	-	-	-	-	-	-	-	-	-	-
Santa Anita	Proposed Line 489 would link Arcadia and LA Union Station during peak hours on weekdays via Rosemead Bl, Valley Bl, Del Mar Av, I-10 Express Lanes: •Frequent Metro Red/Purple/Silver Line services would serve downtown LA and Westlake/MacArthur Park in place of Line 489 west of Union Station	-	-	-	-	-	-	8.5	30	8.5	30	60	-	-	-	-	-	-	-	60	60	60	60	60	-	-	-	-	-	-	-	60	60	60	60	60	-

Line	Service Change Proposal	Existing Weekday Frequency						Proposed Weekday Frequency						Existing Saturday Frequency						Proposed Saturday Frequency						Existing Sunday Frequency						Proposed Sunday Frequency								
		AM Peak	Midday	PM Peak	Evening	Late Night	Owl	AM Peak	Midday	PM Peak	Evening	Late Night	Owl	AM Peak	Midday	PM Peak	Evening	Late Night	Owl	AM Peak	Midday	PM Peak	Evening	Late Night	Owl	AM Peak	Midday	PM Peak	Evening	Late Night	Owl	AM Peak	Midday	PM Peak	Evening	Late Night	Owl			
R501	Line 501 would continue to link North Hollywood, Burbank, Glendale, and Pasadena, with the following changes: •A new route for Line 501 is proposed in Burbank to simplify and expedite service through the Media District by operating on Alameda Av instead of Olive Av •A new route for Line 501 would operate in downtown Glendale via Brand Bl and Broadway with a new Line 501 stop to serve the Americana at Brand and Glendale Galleria •A new route and stop for Line 501 would serve the LA Zoo and Griffith Park	12	30	12	25	-	-	15	30	15	30	-	-	45	45	45	45	-	-	30	30	30	30	-	-	45	45	45	45	-	-	30	30	30	30	-	-			
R534 R134	New Line 134: Line 534 would be renumbered to 134. There are no route changes for New Line 134 between Malibu and Santa Monica.	20	60	30	50	-	-	-	-	-	-	-	-	25	60	30	50	-	-	-	-	-	-	-	-	60	60	45	60	-	-	-	-	-	-	-	-			
R550	Express Line 550 would be discontinued due to underutilized service and service duplication with other bus lines. Alternative bus service would be provided by Metro E Line (Expo) and Silver Line 910, Torrance Transit Line 1 on Vermont Av from Harbor Gateway Transit Center, and Metro Line 205 on Vermont Ave and 7th St in San Pedro from Carson Transitway Station.	30	60	30	60	-	-	-	-	-	-	-	-	60	60	60	60	60	-	-	-	-	-	-	-	-	60	60	60	60	60	-	-	-	-	-	-	-	-	
R577	Line 577 between El Monte Station and Cal State Long Beach via I-605 would change as follows: •Reroute service between El Monte Station and Rio Hondo College via the I-10 and I-605 freeways instead of Santa Anita Ave and Peck Rd, providing faster and more direct service •Discontinue the deviation to Los Cerritos Center due to low ridership, providing faster and more direct service to/from Cal State Long Beach and VA	40	45	40	50	-	-	30	30	30	60	60	-	-	-	-	-	-	-	-	-	-	-	-	-	-	-	-	-	-	-	-	-	-	-	-	-	-		
R603	Line 603 would continue on the current route between Glendale Galleria and downtown LA, with more frequent service during the midday hours on weekdays: •Line 603 would be rerouted via Glendale Station, providing direct connections with Metrolink and Amtrak.	10	20	12	25	-	-	12	12	12	15	30	-	-	25	20	15	20	-	-	20	20	20	20	30	-	-	30	20	15	20	-	-	20	20	20	20	30	-	-
R605	Line 605 would operate between LA County USC Medical Center and Olympic Bl/Grande Vista Av and be extended west on 8th St to end at Olympic Bl/Soto St, improving connections with Lines 66, 251, and 665. Line 605 would provide more frequency during midday hours on weekdays and weekends.	15	25	15	-	-	-	15	15	15	30	30	-	-	30	35	35	-	-	-	20	20	20	30	30	-	-	30	35	35	-	-	-	20	20	20	30	30	-	-
R607	Line 607 would be discontinued due to underutilized service. Nearest alternative bus service would be on Slauson Av (Line 108), Hyde Park Bl (Line 110), Manchester Av (Line 115), Crenshaw Bl (Line 210), and La Brea Av (Line 212).	60	-	60	-	-	-	-	-	-	-	-	-	-	-	-	-	-	-	-	-	-	-	-	-	-	-	-	-	-	-	-	-	-	-	-	-			
R611	Line 611 Huntington Park Shuttle would be discontinued due to underutilized service and service duplication of other bus lines. This line currently is operating on Florence Av, Compton Av, Vernon Av, Leonis St, Wilcox Av, and Santa Ana St.: •Alternative bus services would be available on Florence Av (Line 111), Compton Av (Line 55), Vernon Av (Line 105), Leonis (see Line 102 information sheet), Atlantic Bl (Line 260), Seville Av and Pacific Bl (Line 60)	45	60	50	60	-	-	-	-	-	-	-	-	60	60	60	60	-	-	-	-	-	-	-	-	60	60	60	60	-	-	-	-	-	-	-	-			
R612	Line 612 South Gate Shuttle would be discontinued due to underutilized service and service duplication of other bus lines. This line is currently operating on Wilmington Av, Compton Av, 92nd St, Santa Fe Av, Florence Av, Otis St, Abbott Rd, Atlantic Av, Martin Luther King Jr. Bl, and Imperial Hwy: •Alternative bus services would be available on 103rd St (Line 117), Compton Av (Line 55), Long Beach Bl and Pacific Bl (Line 60), Florence Av (Line 111), Atlantic Av (Line 260), Martin Luther King Jr. Bl (see Line 261 information sheet), and Imperial Hwy (Line 120)	60	60	60	60	-	-	-	-	-	-	-	-	60	60	60	60	-	-	-	-	-	-	-	-	60	60	60	60	-	-	-	-	-	-	-	-			
R625	Line 625 would be discontinued due to underutilized service. Nearest alternative bus service would be Metro Line 232 on Sepulveda Bl and Beach Cities Transit Line 109 on Imperial Hwy.	20	-	20	-	-	-	-	-	-	-	-	-	-	-	-	-	-	-	-	-	-	-	-	-	-	-	-	-	-	-	-	-	-	-	-	-			
R662	New Metro Line 662 would operate two-directional service on Lake Av, Altadena Dr, Lincoln Av, Washington Bl, and Los Robles Av between Pasadena (Gold Line Del Mar and Lake Stations) and Altadena •New Lines 258 and 662 would both provide new weekend service	-	-	-	-	-	-	30	30	30	30	30	-	-	-	-	-	-	-	-	30	30	30	30	60	-	-	-	-	-	-	-	-	30	30	30	30	60	-	-
R665	Line 665 through East LA would to operate all trips the full route between Olympic Bl/Soto St and Cal State University LA, instead of selected trips starting at Indiana St/Olympic Bl. This change will improve connections with Metro Lines 66, 251, and 605. More frequent Line 665 service would operate every day, including weekends.	40	40	50	40	-	-	30	30	30	30	60	-	-	60	60	60	-	-	-	30	30	30	30	60	-	-	-	60	60	-	-	-	30	30	30	30	60	-	-
R685	Line 685 would be discontinued due to underutilized service. This line currently operates between Glassell park and Glendale City College via Eagle Rock Bl and Verdugo Rd: •Line 28 will continue to serve Eagle Rock Bl •Line 90 will link Gold Line Lincoln/Cypress Station to Glendale City College (see Line 90 information sheet)	30	30	30	30	-	-	-	-	-	-	-	-	-	-	-	-	-	-	-	-	-	-	-	-	-	-	-	-	-	-	60	30	30	60	60	-	-		
R686	Line 686 would operate between Altadena (New York Dr/Allen Av) and Gold Line Del Mar Station in Pasadena and would no longer continue to Fillmore Station, avoiding overlap with new Line 260 and providing improved frequency weekdays.	40	40	40	50	-	-	30	30	30	30	-	-	40	60	60	60	-	-	-	-	-	-	-	-	40	60	60	60	-	-	40	40	40	40	-	-			
R687	Line 687 would be discontinued due to underutilized service and duplication of bus service or proximity to other bus routes. This line currently operates between Altadena and Gold Line Del Mar and Fillmore Stations in Pasadena via Los Robles Av, Colorado Bl, and Fair Oaks Av/Raymond Av. Alternative bus service would be available as follows: •Frequent New Line 660 will be available on Fair Oaks Av •Frequent New Line 662 will be available on Washington Bl, Los Robles Av, and Lake Av •Pasadena Transit will be available in the area	40	40	40	50	-	-	-	-	-	-	-	-	30	60	60	60	-	-	-	-	-	-	-	-	30	60	60	60	-	-	-	-	-	-	-	-			
R690	New Line 690 would operate between Lake View Terrace and Sylmar via San Fernando Rd., Maclay Ave., Foothill Blvd. and Terra Bella St.	-	-	-	-	-	-	30	30	30	30	30	-	-	-	-	-	-	-	-	30	30	30	30	30	-	-	-	-	-	-	-	-	30	30	30	30	30	-	-
R901	The Orange Line will continue to serve as a critical arterial service linking destinations across the San Fernando Valley, with more frequency for midday and late evening on weekdays.	5/10.	10	5/10.	10	20	40	10	10	10	10	15	30	12/30.	10/20.	10/20.	15	20	40	10	10	10	10	15	30	12/30.	10/20.	10/20.	15	20	40	10	10	10	10	15	30			
RS901		-	-	-	-	-	-	10	-	10	10	-	-	-	-	-	-	-	-	-	-	-	-	-	-	-	-	-	-	-	-	-	-	-	-	-	-			
R601		10	10	10	10	20	20	10	10	10	10	20	20	15	10	10	15	20	20	15	10	10	12	20	20	15	10	10	15	20	20	15	10	10	12	20	20			
Orange Line	There are no changes for Line 601.	-	-	-	-	-	-	5	10	5	5	15	20	-	-	-	-	-	-	10	10	10	10	15	20	-	-	-	-	-	-	10	10	10	10	15	20			
R910	The Silver Line 910 will continue operating as usual between El Monte, downtown LA and Harbor Gateway Transit Center. New Line 510 would replace Line 950 and operate between Harbor Freeway Station and San Pedro via the I-110 Freeway, remaining on I-110 and bypassing Harbor Gateway Transit Center for faster service to San Pedro.	5	30	5	30	20	60	5	10	5	10	15	30	30	30	30	40	20	60	15	15	15	20	20	30	30	30	30	40	20	60	15	15	15	20	20	30			
R950	New Line 510 would maintain convenient, same platform transfers with Silver Line 910 at Rosecrans Station, and provide connections with the future Crenshaw/LAX Line at Harbor Freeway Station.	15	30	20	40	-	-	-	-	-	-	-	-	40	30	30	40	-	-	-	-	-	-	-	-	40	30	30	40	-	-	-	-	-	-	-	-			
R510	Additional Silver Line 910 trips would operate in place of Line 950 between El Monte and Harbor Gateway Transit Center. This change would improve Silver Line 910 reliability and allow for the transition to operating new Zero Emission Buses on the Silver Line.	-	-	-	-	-	-	15	30	15	20	30	-	-	-	-	-	-	-	-	30	30	30	30	30	-	-	-	-	-	-	-	-	30	30	30	30	30	-	-
Silver Line		-	-	-	-	-	-	5	10	5	10	15	30	-	-	-	-	-	-	15	15	15	20	20	30	-	-	-	-	-	-	15	15	15	20	20	30			

TABLE OF CONTENTS

LIST OF TABLES AND FIGURES 3

EXECUTIVE SUMMARY 5

SECTION 1: INTRODUCTION, PURPOSE & BACKGROUND 6

SECTION 2: DESIGNING A WORLD CLASS BUS SYSTEM 10

SECTION 3: SERVICE DESIGN GUIDELINES 13

 3.1 Service Design Concepts 13

 3.2 Service Standards 16

 3.3 Metro Bus Routing Guidelines 19

 3.4 Vehicle Assignment 22

 3.5 Charter Service 23

 3.6 Special Event Service 24

 3.7 Service Transfer Guideline 24

 3.8 Alternative Service Delivery Options 26

SECTION 4: CUSTOMER INFORMATION AND AMENITIES 27

 4.1 Customer Information 27

 4.2 Customer Amenities 28

 4.3 Rail Stations and Major Off-Street Bus Facilities 29

 4.4 Bus Stop Amenities 30

 4.5 Bus Stop/Station Location, Design and Guidelines 31

SECTION 5: SERVICE PERFORMANCE EVALUATION 38

 5.1 Route Performance Index 38

 5.2 Customer Experience 39

 5.3 Service Evaluation Process 40

SECTION 6: SERVICE CHANGE PROCESS 42

 6.1 Service Change Programs 44

 6.2 Title VI and Metro’s Equity Platform 44

 6.3 Title VI Equity Analysis 46

 6.4 Public Outreach 49

 6.5 Public Hearing Process 51

 6.6 Implementing Minor Changes on an Interim Basis 51

APPENDICES..... 52

 APPENDIX A: Metro Line Identification..... 53

 APPENDIX B: Los Angeles County Local Fixed and Demand Response Route Transit
 Operators..... 57

LIST OF TABLES AND FIGURES

SECTION 1: INTRODUCTION, PURPOSE & BACKGROUND

Table 1.1 Metro Bus Service Types and Features.....6
Table 1.2 Service Type Determination.....7

SECTION 3: SERVICE DESIGN GUIDELINES

Table 3.1 Service Design Concepts.....16
Table 3.2 Maximum Headway by Service Type.....16
Table 3.3 Passenger Loading Standards by Vehicle Type.....17
Table 3.4 Maximum Avg. Stop/Station Spacing.....18

Figure 3.1 40-foot bus turning radius.....20
Figure 3.2 45-foot bus turning radius.....21
Figure 3.3 Articulated 60-foot bus turning radius21

SECTION 4: CUSTOMER INFORMATION AND AMENITIES

Table 4.1 Passenger Amenities.....30
Table 4.2 Comparative Analysis of Bus Stop Locations.....33

Figure 4.1 General Standard Bus Stop/Zone Attributes.....35
Figure 4.2 Typical Near-Side Bus Stop.....36
Figure 4.3 Typical Far-Side Bus Stop.....37
Figure 4.4 Typical Mid-Block Bus Stop.....38

SECTION 6: SERVICE CHANGE PROCESS

Table 6.1 Service Change Timeline.....44
Table 6.2 Timeline for Public Notification Activities.....51

Figure 6.1 Metro Service Council Areas.....43
Figure 6.2 Service Change Process.....46

This page intentionally left blank.

EXECUTIVE SUMMARY

Los Angeles County Metropolitan Transportation Authority (Metro) serves as transportation planner and coordinator, designer, builder and operator for Los Angeles County. More than 8.6 million people live, work, and play within its 1,469-square-mile service area.¹

In 2018, the Board adopted Metro Vision 2028 as the agency's strategic plan. The plan outlines five goals to guide the development of transportation in LA County. Metro must ensure that: our customers feel safe when riding, that they do so in clean equipment, service is reliable and on-time, and our staff provides service in a courteous manner.

Goal 1: Provide high-quality mobility options that enable people to spend less time traveling

Goal 2: Deliver outstanding trip experiences for all users of the transportation system

Goal 3: Enhance communities and lives through mobility and access to opportunity

Goal 4: Transform LA County through regional collaboration and national leadership

Goal 5: Provide responsive, accountable, and trustworthy governance within the Metro organization

Metro's Transit Service Policy (TSP) establishes criteria and guidelines to ensure that the transit system is developed and managed consistent with policy guidance approved by the Metro Board of Directors, including a formal process for evaluating services, service design guidelines, and a process for implementing service changes.

¹ FY19 National Transit Database

SECTION 1: INTRODUCTION, PURPOSE & BACKGROUND

Metro operates a comprehensive bus and rail network that complements Metro Rail and municipal operator services. Determining the most appropriate transit service in a corridor depends on several factors such as level of demand, resource availability, site or corridor characteristics, environmental considerations, and community acceptance. The characteristics that determine which type of service is most appropriate are summarized in Table 1.1.

Table 1.1 *Service Type Determination²*

Service Type	Corridor	Optimal Characteristics
Heavy Rail (Subway)	Operate 100% within an exclusive right of way.	- 2,500 boardings per route mile or more than 50,000 boardings per day. - Ability to construct a fully grade-separated facility.
Light Rail	Operate in mixed flow traffic or an exclusive right of way.	- 1,000 boardings per route mile or more than 25,000 boardings per day. - Ability to construct a guideway within or adjacent to the corridor.
Commuter Routes	Operate in mixed flow traffic in along either an HOV or HOT Lane and may operate a segment of their route on local streets.	300 or more boardings during peak-hour and in peak direction of travel.
BRT and Rapid	Operated using 40', 45' or 60' buses. - Metro G Line (Orange) (BRT) operates on a fixed guideway. - Metro Rapid and Hybrid Lines operate in exclusive bus lanes or mixed flow traffic on local streets with signal priority.	- 300 or more boardings during peak-hour and in peak direction of travel. - Daily average of more than 500 boardings per route mile or more than 10,000 daily boardings. - Ability to implement operating speed improvements in the corridor.
Core, Convenience, Connectivity and Community Routes	Operate in mixed flow traffic on local streets by 32', 40', 45', or 60' buses.	- The median bus route carries about 4,500 daily boardings. - Core and Convenience services are expected to carry more than the daily median, while Connectivity and Community are anticipated to carry less.

Metro Bus

Metro currently operates 165 bus routes, of which 18 routes are contracted out. Metro serves nearly 14,000 bus stops, including station stops on the G Line (Orange) and J Line (Silver) BRT systems. On weekdays, Metro operates a fleet of over 2,300 buses. Metro’s bus operations consist of both directly operated and contract operated services. Metro operates the largest

²Capacity limits adapted from TCRP, Research Results Digest, November 1999—Number 35, Highlight of Large Transit Capacity and Quality of Service Manual, Figure 1 Achievable Capacity (Peak direction passengers/hour)

share of all bus services provided in the region. Municipal and Local Return operators provide additional public bus and paratransit services in areas of the region where Metro provides limited service or no service at all.

Metro classifies its bus services into tiers stratified by the frequency of service. The tiers are assigned to individual routes in accordance with demand and propensity for future growth. Table 1.2 describes the features of each of Metro’s bus service types. Tier definitions are:

- **Core (Tier 1):** weekday all day headways of 7.5 minutes or better
- **Convenience (Tier 2):** 7.5 to 10 minutes
- **Connectivity (Tier 3):** 10 to 15 minutes
- **Community (Tier 4):** 15 to 30+ minutes
- **Commuter (Tier 5):** Varies

Table 1.2 *Metro Bus Service Types and Features*

Feature	Bus Service Type			
	BRT	Rapid	Commuter	Core, Convenience, Connectivity, Community
Right of Way	Dedicated right-of-way	Major arterials	Major arterials and freeways.	Major arterials and local streets
Minimum Average Stop Spacing	1.25 miles	0.75 mile	1.25 miles	0.2 - 0.30 mile
Target Travel Market	Inter-community	Inter-community	Inter-community, regional	Inter-community, neighborhood
Vehicle Type	45/60-foot buses	40/45/60-foot buses	40-foot bus	40/45/60-foot buses
Communities Served	Multiple	Multiple	Multiple	Multiple
Signal Priority	Yes	Yes	No	
Fare Collection	On board /pre-pay	On Board	On Board	On Board
Passenger Amenities	Shelters and stations	Shelters and stations	Shelters and stations	Benches and shelters
Real-time Passenger Info	Yes	Yes	Yes	

Note: Proposed stop spacing standards provide for the average stop spacing in miles by type of service and spacing should fall within 0.1 mile of the specified average at least 90% of the time.

Metro Bus Rapid Transit (BRT)

To support BRT, Metro incorporates a series of design features to reduce delays, increase reliability and improve customer comfort. Metro operates two high-capacity vehicle types: 45-foot buses with 46 seats and articulated 60-foot buses with 57 seats. Ideally, high-capacity vehicles should primarily be operated on high-volume trunk service routes with more than

10,000 total daily boardings. Metro BRT services operate on an exclusive right-of-way, major arterials, or in HOV/HOT lanes.

Metro operates two such routes: the G Line (Orange) which operates on its own exclusive right-of-way, and the J Line (Silver) which operates on the I-10 and I-110 ExpressLanes (freeway toll lanes) as well as surface streets through downtown. These are considered Tier 1 services. BRT services charge a premium fare.

- **Dedicated Bus Lanes:** A bus lane is an exclusive lane used by transit on urban streets along a roadway through widening or dedication of one or more existing general traffic or parking lanes for transit use. These lanes can be designated for transit use during peak periods only or all day. Bus lanes typically allow use by general traffic for right turn movements, bicycles, parking, and local access to and from driveway, and are most effective in those areas where there are very high bus or customer volumes and where operational efficiencies can be achieved. Bus lanes should be a minimum of 17 feet wide. This right of way provides fewer traffic conflicts and obstructions and reduces delays and travel time. Metro is currently studying the feasibility of adding bus lanes on several major corridors to further improve travel times.
- **High-Capacity Vehicles:** State-of-the-art high-capacity vehicles are used to meet high demand and provide greater customer comfort.
- **Transit-Signal Priority:** An operational strategy that facilitates the movements of in-service transit vehicles through signalized intersections to improve transit performance by extending the green phase or shortening the red phase of traffic signals.
- **Bus Stations and Shelters:** Stations and shelters provide customers with enhanced comfort and safety.
- **Streetscape:** Streetscape and other design features such as landscaping, pedestrian count-down signals, bicycle racks, and well-designed crosswalks make it easier for pedestrians and bicyclists to access the stations.
- **Improved Fare Collection:** For faster service and convenience, major stations have ticket vending machines (TVMs) which allow customer s to preload their TAP cards.
- **Park & Ride Facilities:** Provided in close proximity to major stops and stations. Adjacent development and joint use parking are encouraged.
- **Advanced Transportation Management Systems:** ATMS provide an array of technologies to improve service reliability and customer travel.

The advantage of their deployment is the opportunity to reduce vehicle requirements and service hours; however, deployment should not increase service intervals to the point where service quality is degraded. For this reason, bus lines with a peak headway of five minutes or less are ideal candidates for this type of vehicle. In evaluating services for higher capacity vehicles, other factors must be considered including facility compatibility, street design, and potential impacts to services where schedules have been interlined.

Metro Rail

Metro operates two heavy and four light rail lines serving a total of 96 stations across approximately 101 route miles, with a fleet of 406 heavy and light rail cars.

Metro Rail operates in heavily congested travel corridors and provides connections to key multi-modal transportation hubs. Metro operates two types of rail service to better match the transit mode with specific customer demand and needs. Metro Rail is high-capacity rapid transit service operating along a dedicated right-of-way, serving full-scale transit stations, and powered by electricity. The rail system supports public transportation in the greater Los Angeles region, linking many key multi-modal transportation centers and destinations together.

Rail service operates in high-demand travel corridors and is offered in two forms – heavy rail and light rail. Metro’s heavy rail is the subway system served by the B and D Lines (Red, Purple) powered by a third rail. Metro’s four light rail lines – A (Blue), C (Green), L (Gold) and E (Expo) – are powered by overhead catenary wires, generally use shorter trains, and operate at slower speeds than heavy rail. Unlike heavy rail, light rail lines run along a right-of-way ranging from complete grade separation to at-grade in mixed flow traffic.

Transit Service Policy (TSP)

The TSP was originally adopted in 1986 and is reviewed on an annual basis. This document sets forth the policies, principles, and service guidelines that are used by Metro staff in the design or modification of the bus network to better serve customers and make more beneficial use of available operating resources. This document outlines the service change process that provides the quantitative tools to evaluate the system, identifies opportunities for service improvements, and ensures the regional transit system is adjusted according to the service goals and objectives approved by the Metro Board.

The TSP is updated as needed to better reflect agency goals and objectives, major initiatives, and changes in local, state, and federal regulations and funding.

This document updates the most recent version adopted by the Board in FY2016.

SECTION 2: DESIGNING A WORLD CLASS BUS SYSTEM

In 2018, the Board adopted Metro Vision 2028 as the agency's strategic plan. The plan outlines five goals to guide the development of transportation in LA County. The NextGen Bus Study was also initiated in 2018 to reimagine the Metro bus network to be more relevant, reflective of, and attractive to the diverse customer needs within Los Angeles County. NextGen addresses **Goal #1: Provide high quality mobility options that enable people to spend less time traveling.** The study also encompasses two sub-goals: 1) Target infrastructure and service investments towards those with the greatest mobility needs; and 2) Invest in a world class bus system that is reliable, convenient, safe, and attractive to more users for more trips.

In addition to the strategic plan, the Board adopted Motion 38.1 (June 2018), endorsing travel speed, service frequency, and system reliability as the highest priority service design objectives for the NextGen Bus Study. Finally, regardless of the level of resources expended on the bus network, optimizing system performance should always be an objective in network design to maximize benefit to the public.

These goals and objectives drive the development of the NextGen Service Plan, including routing, stop spacing, frequency, span of service, and coordination with municipal operators. In addition, a set of performance measures have been defined below to ensure the bus network continues to evolve consistent with the goals and objectives defined by the Board.

NextGen Service Plan

Metro Vision 2028 envisions building a World Class Transportation System in which a World Class Bus System is a cornerstone to its success. Building a World Class Bus System requires improving the attractiveness and competitiveness of the bus network. Attractiveness includes addressing issues such as safety and security, cleanliness, comfort, real time arrival information, easy fare payment, wayfinding and signage, and first/last mile access. Competitiveness requires developing a bus network that minimizes the overall travel time to complete a trip compared to the driving alternative. This travel time considers directness of route, access to the bus stop, waiting time, and onboard travel time.

NextGen's primary purpose is to improve the competitiveness of the bus network. However, through this process, improvements to certain aspects of attractiveness can also be achieved. The following outlines a strategy for how NextGen will set the foundation for building a World Class Bus System.

Step 1: Reconnect Scenario: Metro currently provides roughly 7 million revenue service hours (RSH) of bus service per year. The first step in creating a World Class Bus System is to redesign the routes and schedules to attract trips where and when there is the greatest market potential. The lessons learned in Phase 1 of the bus study present a path forward for reinventing the bus network:

- **85% of LA County residents have used transit at least once in the past year, THEREFORE, we should attempt to maintain coverage throughout the County by minimizing discontinued segments.**

- **Fast/Frequent/reliable service is key**; THEREFORE, we need to create a competitive transit network that reduces overall travel time by optimizing all components of the trip, including walking, waiting, and riding.
- **Metro’s current system is not always competitive to get people where they want to go**, THEREFORE routing should be adjusted to reflect the key origins and destinations identified in the cell phone location data.
- **The greatest opportunity to grow ridership is between midday & evening when many trips are short distance**, THEREFORE service levels should be improved for midday, evenings and weekends.
- **Need to integrate Metro’s Equity Framework into the planning process**, THEREFORE service improvements should be prioritized for equity-focused areas.

These lessons learned to “reconnect” routes and schedules with where and when people travel today were incorporated into the Service Design Guidelines outlined in Section 3 to develop the NextGen Reconnect service plan. Reconnect is estimated to increase ridership by 5% with no additional increase in revenue service hours.

Step 2: Transit First Scenario: Once the bus network is reestablished to reflect the travel patterns of today, the next step in building a World Class Bus System is to: 1) invest in speed and reliability infrastructure, 2) create safe and comfortable waiting environments, 3) improve the boarding and riding experience, and 4) establish facilities to optimize layovers. These capital improvements create a more competitive and attractive bus network while saving resources to be reinvested into more service.

- **Speed and Reliability Improvements** – As bus system speeds continue to decline, Metro must allocate an additional \$10 million cumulatively every year to provide the same amount of service. Not only does this reduce the opportunity to increase service, it degrades our competitiveness and attractiveness. Therefore, investing to improve the speed and reliability of the bus system is critical to the success of NextGen. Some improvements can be implemented within METRO’s control, such as optimizing stop spacing, all door boarding, and headway-based service management. However, other improvements can only be implemented through collaboration with local jurisdictions, including transit priorities, bus bulb outs, and bus only lanes. Under the Transit First scenario, \$750 million in capital improvements are proposed to support speed and reliability improvements for the regional bus network. This investment is anticipated to save 25%-34% in system speed if fully implemented.
- **Customer Wait Environment** – Through the significant public outreach conducted in Phase 1, as well as other Metro efforts such as the How Women Travel Study, we learned that an uncomfortable and unsecured wait environment is a significant barrier for customers in using the bus network. This is particularly concerning for women who account for over half of our customers and often travel with young children. Metro completed the Transfer Design Guideline in March 2018. Under the Transit First scenario, we plan to begin implementing the recommendations from this policy document at our busiest wait and transfer locations. This investment is anticipated to cost \$150 million

and address several of the safety and comfort issues identified in the NextGen outreach and How Women Travel Study.

- **Boarding and Riding Experience** – Metro has implemented All Door Boarding on several lines, including G Line (Orange), J Line (Silver), Line 720 (Wilshire), and Line 754 (Vermont). Experience on the J Line (Silver) showed that dwell times were reduced by 15% on average, on time performance improved, cash payment declined with more TAP penetration, and significant customer and operator satisfaction. Other strategies to improve boarding and on board experience include level boarding at key stops and improved on board information. These improvements are estimated at \$100 million systemwide.
- **Layover Optimization** – Due to limited curb space, many routes are extended purely to access a layover location. These unnecessary route extensions cost several million dollars in operating cost per year with little to no benefit to the customer. By investing in off street layover terminals to optimize layover locations, we can reallocate wasted resources and reallocate it to more productive use. In addition, these locations would provide facilities for better regional mobility coordination, a better wait and rest environment for customers and operators, improve bus service reliability, and opportunities for new en route Zero Emissions Bus (ZEB) charging infrastructure.

This \$1 billion capital program is expected to achieve resource savings by generating more revenue service miles/trips within the same revenue service hours. These savings would be reinvested into Transit First service improvements, including:

- Ensure that all bus lines operate seven days per week;
- Ensure no wider than 30 minute headways on any line between 6:00 am and 7:00 pm;
- Expand owl (overnight) service on an additional eight lines;
- Increase weekday midday and evening service levels;
- Increase weekday evening service levels.

Investing “one time” capital dollars into transit supportive infrastructure would increase the attractiveness and competitiveness of the bus network, while freeing resources to reinvest into service enhancements. Under the Transit First scenario, these benefits are expected to generate a 15-20% increase in ridership (10-15% over Reconnect) without additional increases in revenue service hours.

Step 3: Future Funding Scenario: Should future funding be secured through efforts such as de-congestion pricing, additional resources can be added to the Transit First network. However, without disincentives for driving, there will be diminishing returns on benefits since most customers would already have been served within the Transit First Scenario. Therefore a 34% increase in revenue service hours would only be expected to yield a 10% increase in ridership over Transit First.

SECTION 3: SERVICE DESIGN GUIDELINES

Key Principles of Network Design

Three key elements are taken into consideration during the Network Development Process to identify when and where transit can be successful.

- **Transit Propensity** – Areas where the propensity to use transit is the greatest embody three main characteristics. First, there is a significantly large population of transit market segments, including people who rely on transit for most of their travel, commuters and students who use transit for work and school trips, and discretionary customers who choose transit for some or all their trips. Second, is the intensity of travel demand to and from areas based on population and employment densities, retail and entertainment, colleges and universities, and other trip generators. A pedestrian oriented street environment is also critical, including safe and well lighted pathways, sidewalks and curb-cuts, grid street network, and level topography.
- **Existing Service Performance** – It is important to identify the most productive segments of the existing bus network which articulates current transit demand. These corridors and routes should be optimized through the network development process, and lessons learned should be applied to other areas with similar demand and service characteristics.
- **Service Environment** - A transit-oriented service environment is also critical to the success of transit, including the pedestrian orientation of the streets and land use, barriers to other modes such as limited and costly parking supply, and transit supportive infrastructure including bus only lanes and transit priorities.

Once these key elements are taken into consideration in the Network Development Process, this transit orientation can then be translated into design considerations, including elements explained in the following sub-sections.

3.1 Service Design Concepts

Service design concepts, developed as part of the NextGen Bus Study, are guidelines established based on the feedback received through the study's stakeholder and public outreach sessions. Network characteristics most important to the public include:

- Faster service
- Frequent service throughout the day
- More reliable service
- Better network connectivity
- Accessibility to key destinations
- Improved security

Based on these service themes, the following service design concepts will guide the design of the Metro bus network:

Hybrid Local/Rapid Stop Spacing – Currently stop spacing is determined by route classification. For example, local lines are planned with $\frac{1}{4}$ mile stop spacing while Rapid lines have $\frac{3}{4}$ to 1 mile stop spacing. As a result, customers travelling on local lines go slower between communities but have closer access to origins and destinations. Conversely, Rapid customers

travel faster along a corridor, but may be picked up or dropped off much further from their origin or destination. In addition, resources are split between the local and Rapid lines resulting in wider headways for each service. Therefore, overall end to end travel time including walking/rolling to the stop, waiting for the bus and finally the in-vehicle run time may result in longer travel times on the Rapid, especially for shorter distance trips.

Consolidating local and Rapid resources along a corridor will provide much better headways, and customizing stop spacing along the corridor based on changing land use densities along a corridor results in shorter wait times, faster on board travel times compared to the local, and shorter walk/roll compared to Rapid service. In addition, this standardizes the frequency along the entire corridor, vs inconsistent frequencies between local and Rapid services that have different speeds.

Shorter Route Lengths and Subarea Transit Hubs – The cell phone location based data indicates that almost half of all travel in Los Angeles County are within 1 to 5 miles. In addition, the origin-destination travel patterns indicate that many people travel locally and not necessarily regionally across the region. Creating shorter route lengths will improve schedule reliability. Being able to tie the lines to subarea transit hubs will improve network efficiencies and provide a safer and more convenient location for transfers.

Municipal Operator Coordination – Metro serves as LA County’s regional coordinator of transit services. Improved coordination between all operators and modes is vital to establishing an integrated regional transit network. Metro operates within a hierarchy of services, in which Metrolink provides the region’s commuter rail to serve high volume, longer distance trips. Metro Rail, Metro BRT [G Line (Orange) and J Line (Silver)], and Metro Bus serves as the backbone of the urban transit network, which is augmented by municipal operators. Municipal and local return operators complement the system with community and shuttle buses that serve specific neighborhood needs.

Roughly one third of transit service in LA County is provided by municipal bus operators and Metrolink. Their coverage is especially strong in Santa Monica, South Bay, Gateway Cities, and eastern San Gabriel Valley. Therefore, it is imperative that Metro bus service is closely coordinated with municipal transit service. Given that several of the municipal operators are currently undergoing their own system redesigns, there is an opportunity to work together to develop service change ideas between Metro and municipal services to improve overall coordination for customers.

MicroTransit and Other On-Demand Services – Some areas of the County are difficult to serve with fixed route transit due to terrain, narrow streets, and dispersed lower density destinations. In addition, travel activity in some areas are low during certain times of day or days of week. Metro is currently piloting Mobility on Demand and will be implementing a pilot program for MicroTransit. These service modes may be more appropriate for areas and times of day where fixed route cannot be competitive and will be considered for application in lieu of fixed route if warranted.

Standardize Frequencies by Service Tiers – Currently, schedules are written based on the Board-adopted load standard for frequent services (15 min or better) and based on policy for infrequent services (wider than 15 min). To ensure the core network has consistent frequencies and span of service, corridors will be categorized into tiers based on transit propensity, current ridership, and overall travel demand. Each tier will be assigned a frequency designation (e.g. 10 min peak/12 min base) to ensure that all services within the tier provide consistent service levels for ease of transfer along the network. If a line requires better frequencies than the tier designation, it will be set based on the Board-adopted load standard.

Routing to Reflect Current Travel Patterns and Transit Propensity – Currently corridors are being evaluated by segments. Based on the origin – destination travel patterns identified using the cell phone location based data as well as regional TAP data, the segments will be connected together to create lines. Better aligning the routing with travel patterns is expected to reduce the number of transfers required to make a trip and increase the distance travelable and access to opportunities along the network within 15 min, 30 min, etc. While resources will be focused in areas with high transit propensity, there will be a concerted effort to maintain service in areas of low demand but with the greatest mobility needs.

Table 3.1 *Service Design Concepts*

	Faster service	Frequent service throughout the day	More reliable service	Better network connectivity	Access to key destinations	Improved security
Routing to reflect current travel patterns and transit propensity				X	X	X
Standardize Frequencies by Service Tiers	X	X				
Subarea transit hubs				X		X
Shorter route lengths			X			
Optimize stop spacing	X		X			
Municipal operator coordination				X	X	
MicroTransit and other on- demand		X			X	
Transit supportive infrastructure	X		X			X

Transit Supportive Infrastructure – The service design will identify transit supportive infrastructure that either improves overall travel time and reliability or reduces inefficiencies in the network. Speed and reliability improvements include bus only lanes, queue jumpers, bus bulb outs, signal retiming, All Door Boarding, fare payment technology, etc. improves the

attractiveness and competitiveness of transit while reducing revenue hours that can be reapplied to better use. Infrastructure that optimizes terminals and layover locations, reduce out of direction movements, and improves transfer movements will reduce non-revenue miles and hours that can be reallocated to revenue service.

Table 3.1 illustrates how each service concept will address the various themes expressed by the public and stakeholders.

3.2 Service Standards

Service standards are established to ensure that service levels are maintained based on board adopted standards.

Headways

The headway standard provides for the maximum scheduled gap (in minutes) between trips in the peak direction of travel at the maximum load point of a line by time of day, and it should not be exceeded for at least 90% of all hourly periods as summarized in Table 3.2.

Table 3.2 *Maximum Headway by Service Type*

Service Type	Peak	Off-Peak
Heavy Rail	10	20
Light Rail	12	20
Core Network	7.5	7.5
Convenience Network	10	10
Connectivity Network	15	15
Community Network	30	30
Commuter Network	varies	varies
Micro-Transit	varies	varies

Passenger Loads

Passenger loading standards have been developed to ensure there is sufficient service capacity on Metro Bus and Rail service. The loading standard for bus is based on the maximum average ratio of customer s to available seating per vehicle size (i.e. 40-foot, 45-foot, and 60-foot buses). The loading standard for rail is based on the maximum average ratio of customer s per seat by service type (i.e. Heavy Rail and Light Rail). Current loading standards are shown in Table 3.3.

- **Bus Passenger Loading Standard** expresses the maximum average ratio of customer s to vehicle size and frequency by direction for a one-hour period that should not be exceeded for at least 95% of all hourly periods. This TSP sets the current loading standard for Metro bus to 1.3 as recommended by the 2016 APTA Peer Review Committee. Vehicles used for MicroTransit or Mobility-on-Demand will have a load standard of 1.0.

- **Rail Passenger Loading Standard** expresses the maximum average ratio of customers to seats by service type and by direction for one-hour period by time of day and should not be exceeded for at least 95% of all hourly periods.

Table 3.3 *Passenger Loading Standards by Vehicle Type*

Service Type	Seats per Vehicle	Passengers per Seat	Maximum Passengers Onboard
Heavy Rail	54	2.30	124
Light rail	76	1.75	133
Bus – 40 foot	38	1.30	49
Bus – 45 foot	46	1.30	60
Bus – 60 foot	57	1.30	74

Wheelchair Boardings and Pass ups.

Ideally, in a floating 6-month period, regular operating bus service will average of no more 6% pass-ups of customers who use wheelchairs or other mobility devices. Should the average increase to over the threshold of 6%, Service Planning will adjust service to better serve the ridership patterns of the route in such a way so as to minimize pass-ups.

Network Route Spacing

Network Route Spacing refers to the average distance between two or more parallel bus and/or rail lines. It is generally accepted that customers are willing to walk up to 0.25 mile to a bus stop. Generally, bus routes operating parallel to each other in an urban area should be spaced 0.5 mile apart from one another and bus routes operating parallel to rail should be spaced a 0.5 mile apart on either side of a rail route. Bus routes operating parallel in a suburban area should be spaced no more than one mile apart from each other, and bus routes operating in low density or underdeveloped areas should be operated where needed in a cost-effective manner. Where possible, alternate delivery methods should be considered.

Bus Stop/Station Spacing

Stop/Station spacing refers to the average distance between consecutive stops/stations along an entire bus/rail route. The standard is expressed as the maximum average stop/station spacing in miles by type of service and is not to be exceeded by at least 90% of all routes operated. Stop/Station spacing is established based on the goals and guidelines each service type is designed to achieve as discussed below. Metro’s maximum average stop/station spacing by mode is summarized in Table 4.3.

- **Heavy/Light Rail Line** station spacing is greater than bus stop/station spacing to achieve the highest speed. Rail station location is determined during the design phase. Ideal average rail station spacing should be no greater than 1.50 miles.
- **BRT and Commuter Bus Routes** achieve the highest bus speeds through even greater stop spacing than Rapid, Core, Convenience, Connectivity, and Community routes. To ensure these services provide access to major activity centers and transfer points, average stop/station spacing should be no greater than 1.25 miles, though there may be exceptions due to geography or existing facility design. See Table 3.4 for further details.

- **Core, Convenience, Connectivity and Community Bus Routes** primarily operate on city streets and secondary streets respectively. These route types are designed to provide service closer to a customer’s destination and reduce walking times. Therefore, average stop spacing should be no greater than 0.25 mile for convenient walk access.

Decisions regarding bus stop spacing and location call for analysis of ridership density, customer service requirements, the safety of customer s, operators, equipment, the service type provided, interaction of stopped buses with general traffic flow. Stops should be closer together in major commercial districts and farther apart in outlying areas.

Table 3.4 *Maximum Avg. Stop/Station Spacing*

Service Type	Stop/Station Spacing
Heavy Rail	1.50
Light Rail	1.50
BRT	1.25
Rapid	0.75
Commuter	1.25
Core, Convenience, Connectivity, Community	0.30

3.2 Bus/Rail Interface Planning

As the Metro Rail system expands, adjustments are made to the bus system to improve access to rail stations, take advantage of new transfer facilities, and reduce bus and rail service duplication. The following guidelines provide direction to routing and scheduling changes that will be necessary as the Metro Rail system is expanded:

Discontinuation of Parallel Limited and Express Service

Competing Commuter services that parallel the rail corridor will be discontinued when duplication exists.

Bus Route Deviation

Bus routes that run parallel to a rail line may be diverted to a station when:

- Walk time from the nearest station is greater than 3 minutes;
- Diversion time in one direction is 5 minutes or less; and
- Net travel time benefit for connecting customer s exceeds increased travel for through travel.

Intersecting bus lines or ones that travel in a perpendicular direction to a rail line will be diverted to serve the closest rail station when:

- Diversion time in one direction is 5 minutes or less
- Net travel time benefit for connections and through travel

Extend Terminating Lines

Bus routes that end within one mile of a rail station will be extended to terminate at the station. Routes that terminate at distances greater than one mile may be extended if the rerouting will create a valuable link to the rail system or will result in a reduction in travel time for a significant number of customers.

New Bus Routes

New rail feeder service will be considered as part of the service change process if a need is demonstrated and if funding is available.

Scheduling Rail/Bus Interface

Bus arrival and departure times should be governed by the rail arrival and departure times when predominant movement is from bus to rail. Bus routes with frequencies of 20 minutes or greater ending at a rail station should be scheduled to arrive 5 minutes before the rail departure time. When the predominant movement is from rail to bus, terminal buses should be scheduled to depart 5 minutes after the scheduled rail arrival time.

3.3 Metro Bus Routing Guidelines

An easy-to-understand-and-use transit system relies on simple network and route design. Consolidating duplicative services on the same or parallel corridors within a quarter-mile to a half-mile distance provides an opportunity to simplify the network for ease of use and reduce unused capacity. This concept requires better coordination of schedules and transfer points and will result in an easier-to-use and more convenient system while reducing wait time and overall travel time.

Metro's directly operated service primarily operates three types of buses: a standard 40-foot bus, a 45-foot bus, and a 60-foot "articulated" bus. To ensure that buses can adequately navigate route alignments and serve bus stops, Metro established the following standards:

- **Transit Centers /Bus Terminals**
 - Layover zones should be designed to accommodate various sizes of buses.
 - Re-striping of layover zones should be completed as needed based on the needs of the service and bus sizes scheduled.
 - Routes should be scheduled so that the amount of layover space needed is available. Layover zones should be placed as close as possible to the route terminal. Where not accommodated by the design, the added operating cost to serve the location will be computed and made part of the decision-making process for bus/rail interface.
- **Minimum turning radius clearance** required for each type size bus movement
 - 50 feet for 40-foot buses (Figure 3.1)
 - 47.5 feet for 45-foot buses (Figure 3.3)
 - 44 feet for 60-foot articulated buses (Figure 3.2)

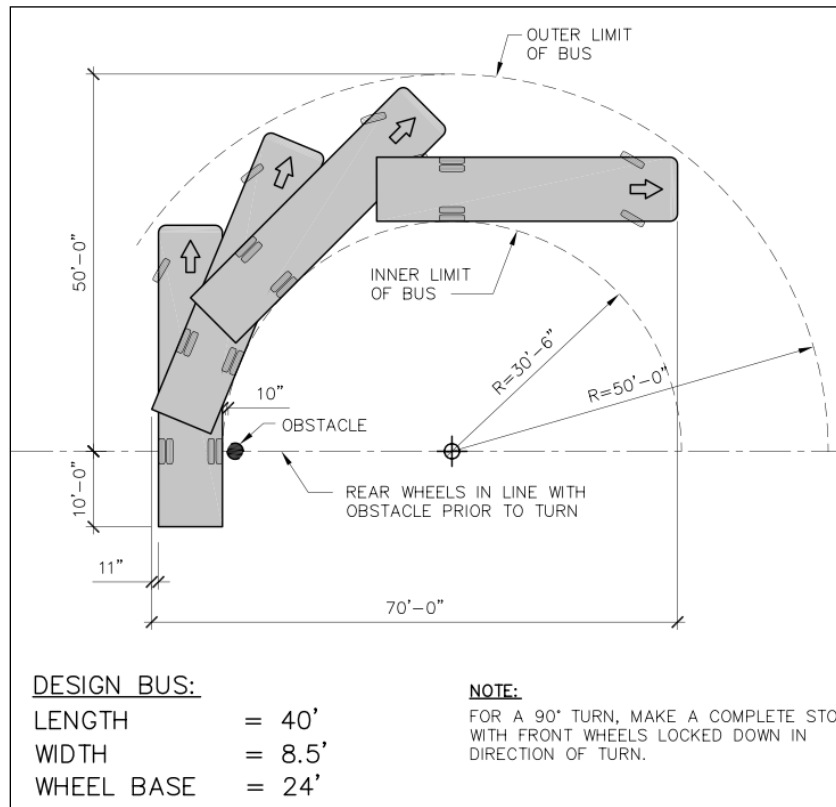

Figure 3.1 40-foot bus turning radius

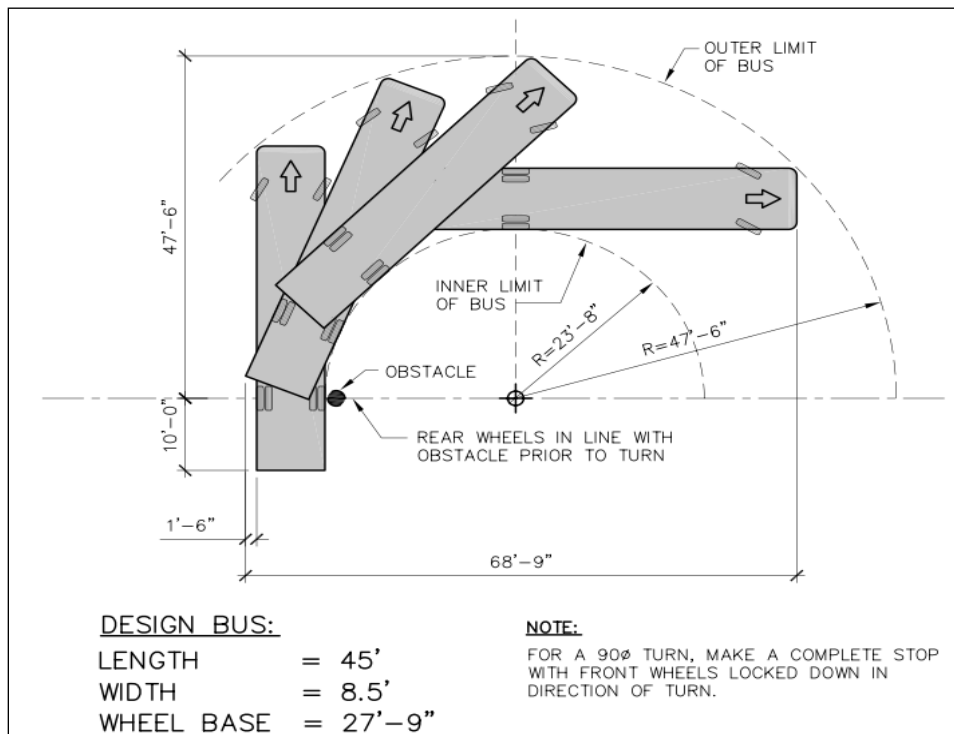

Figure 3.2 45-foot bus turning radius

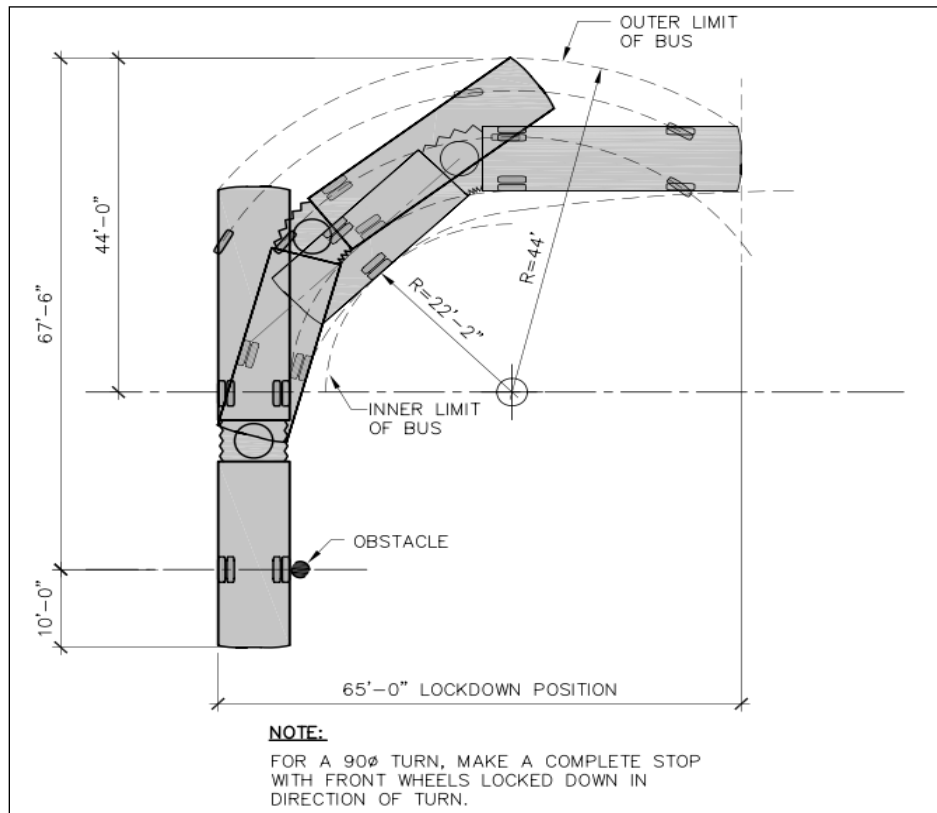

Figure 3.3 Articulated 60-foot bus turning radius

- Desired street lane widths for bus operations should be 12 feet or more.
- **Optimal Bus Stop Curb Lengths and Zone**
40-foot buses should at minimum:
 - Far-side – 90 feet
 - Near-side – 100 feet
 - Mid-block – 150 feet

For two 40-foot buses servicing a stop simultaneously, add 50 feet. Additional bus stop curb length may be needed for 45-foot buses.

60-foot bus should at a minimum:

 - Far-side and mid-block – 120 feet
 - Near-side – 170 feet

For two 60-foot buses servicing a stop simultaneously, add 70 feet.
- **Bus Layover Zone** general space requirements based on frequency between scheduled trips:
 - One space – 15 minutes
 - Two spaces – 12 minutes
 - Four spaces – 6 minutes

3.4 Vehicle Assignment

Metro's goal is to ensure a consistent basis for assigning vehicles to facilities to meet operating needs at a minimal cost and improve quality of service. This policy ensures that operating needs are met at a minimal cost and improve quality of service.

Metro's transit system consists of light rail, heavy rail, and bus operations.³ On any given weekday, Metro serves approximately 925,000 bus boardings and 297,000 rail boardings.⁴

- **Buses:** Buses will be assigned to individual facilities based on vehicle size requirements for lines supported by each facility.
- **Light Rail:** Light Rail cars will be assigned to individual lines based on compatibility of vehicle controllers with each line's signal system. Ideally, the number of vehicle types/manufacturers will be kept to no more than two at any facility to minimize parts storage and maximize maintenance expertise.
- **Heavy Rail:** Assignment policy is not applicable to Heavy Rail. The Metro B Line (Red) and D Line (Purple) operate out of the same division and both are operated by the same vehicle type.

3.5 School Trippers

School trippers are extra service operated to protect against overcrowding on bus routes serving schools. Metro's policy on school trippers is based on FTA regulations (49 CFR Part 605). These regulations are directed at protecting the private sector against unfair competition and ensuring that FTA funding is focused on providing services that meet the needs of the public. School tripper service may be operated if it meets the following criteria:

- There is sufficient demand to warrant the operation of a tripper;
- There are sufficient resources to operate a tripper;
- The school tripper will not result in a significant increase in travel time for regular customers; and
- The school tripper is operated as part of the regularly-scheduled public transportation service.

School tripper service must meet the following requirements:

- All school trippers must fully comply with established policies and procedures;
- All regularly scheduled school trippers must be published on public timetables;

³ Source: lacmta.sharepoint.com/sites/MyMetro/Operations/Pages/Home.aspx

⁴ Figures taken from October 2019 data; selected for seasonal average and adjusted for Blue Line closure.

- All locations where trippers board or alight customers, including the bus stops at deviated routes, must be marked with Metro signage including the bus line numbers servicing the stop;
- School tripper changes must be provided to the public by a service change notice or on the Metro website at www.metro.net; and
- Requests for new school trippers or modifications to existing school trippers will be considered when a notice is given at least two weeks in advance providing ample time to complete an appropriate analysis of the request and to allow appropriate notification of changes to the public.

School tripper services changes must comply with the following procedures

- Service Development Managers (SDM) in the Service Planning & Scheduling Department are responsible for certifying that all school trippers in their respective service area fully comply with Metro’s School Tripper Policy as discussed herein. Each SDM will submit a report prior to each major service change program that details all existing and proposed school tripper service.
- School tripper “pink letters” require notification to the public through use of a service change notice or on Metro’s webpage.
- Uniform standards for the documentation of school tripper pink letters must be employed. This includes standardizing the pink letter form and oversight of the pink letter information being input into the SLS 2000 system to ensure accuracy. All requests for new school trippers and modifications to existing school trippers must be logged into the SLS2000 regardless if the requested new or modified school tripper is implemented.
- SDMs are responsible for working with school districts in their service area which use school tripper service. For example, a specific protocol has been established with LAUSD in which their monthly Operations Coordinators’ Meeting has a standing agenda item, “Metro Coordination,” where special events and bell-time changes are disseminated to Metro through communication with staff and the meeting’s minutes.

3.5 Charter Service

As a grantee of Federal funds, Metro is prohibited from using its federally-funded equipment and facilities to provide charter service except on an incidental basis and when one or more of the applicable exceptions below apply:

- Charter service shall be incidental to the mass transportation service and shall be provided only during times of the day when vehicles are not needed for regularly scheduled service.
- Charter service will only be considered when one of the following exceptions apply:
 - There are no willing or able private charter operators;
 - For special events the private operators are not capable of providing the service;

- When there is a formal agreement regarding the provision of charter services between the recipient and all private charter operators who have been identified to be willing and able; and
 - For government or certain non-profit organizations, if the trip involves a significant number of handicapped persons, or if the organization is a qualified social service agency, or if it receives public welfare assistance funds whose implementation may require transportation services.
- All requests for Charter Service must be approved by the Chief Executive Officer and may require a waiver from the Federal Transit Administration. Petitions for a waiver should be requested in writing 90 days in advance of the event whenever possible.
 - The rates for charter service shall equal or exceed the annual fully allocated cost, including depreciation, of providing charter bus operations, and Metro shall deduct the mileage and hours from the useful life of the buses.
 - The operation of charter service also must comply with relevant state laws, including Section 30630.5 of the California Public Utilities Code.

Charter service is the use of buses, vans or facilities (rail system) to provide a group of persons under a single contract, at a fixed charge, with the exclusive use of the vehicle or service to travel together under an itinerary either specified in advance or modified after having left the place of origin. Generally, for service not to be considered charter, it must meet the following tests:

- Be available to the public;
- Operate within the system's normal scope (existing routings, fit within normal hours of operation and established fare structure);
- Provide a published timetable; and
- Customers must pay their own fare.

3.6 Special Event Service

Special event services are bus routes designed to take customers to a specific venue and are not part of regularly scheduled operations. Metro will provide service under contract to other entities only if the provision of these services does not interfere with Metro's ability to meet regularly scheduled service obligations and fits within the scope of the agency's regular operation in terms of route structure, fares, and span of service. Special event services will be provided on a full cost recovery basis and in conformance with the agency's charter bus policy.

3.7 Service Transfer Guideline

The regional public transit network consists of 17 "Included or Eligible" fixed route operators (including Metro). Included operators (and routes) are those that were operating within LA County in 1971 at the time of adoption of the TDA/STA statute. Eligible operators (and routes) are those added to the Formula Allocation Procedure (FAP) since that time.

Much of the funding for operation of “Included or Eligible” fixed route public transit service in LA County is distributed according to an adopted FAP. The FAP allocates sales tax receipts for public transit each fiscal year in support of public transit throughout the region. Many of the “Included and Eligible” systems operate under the guidelines of the “reserve service areas” established in 1971. Municipal operators have also grown, providing an expanded route network that has improved connections to Metro’s regional lines. In addition, there are numerous Local Return fixed route transit providers who are not eligible for FAP funding, but instead are funded through Propositions A and C (1990 sales tax initiative), Measure R (2008 sales tax initiative), and Measure M (2016 sales tax initiative). These Operators are funded as “Local Return” operators (see Appendix B for a list of operators funded as Local Return and/or Included/Eligible Municipal operators).

Policy guidance states that the network should be well integrated, coordinated, reduce service duplication, and simplify service. Therefore, the evaluation of transit corridors for consideration to be operated in the future by another operator should include:

- Existing performance relative to the system average;
- Value to the customer through integration into an established nearby transit provider;
- Net cost to each operator and the region;
- Completion of another operator’s route network;
- Provide improved connections to a Municipal Operator’s established network;
- Impacts to exiting and projected ridership;
- Generation of a net cost savings to Metro based on Metro’s calculation of the FAP impacts for all service realignment proposals.

Any transfer of directly operated Metro services to a municipal or contract operator must adhere to the terms and conditions governing such transfers as agreed to within the adopted collective bargaining and other superseding agreements between the affected labor unions and Metro.

If a proposed service change is adopted that results in a reduction of service, Metro should reinvest at least half of the net savings (operating cost less customer and FAP reduction) to improve service on Metro’s core network of regionally significant lines in the service area from which the savings were drawn.

Any significant service modifications will be subject to review under Title VI of the Civil Rights Act of 1964, as amended, the approval of the appropriate Metro Service Council(s) and the local transit provider’s Board of Governance, and must be in compliance with local, regional, and labor legislation or agreements. Finally, the agency that assumes service will be required to maintain or improve the days, spread, and frequency of the exiting service for at least a one-year period. In addition, the assuming agency must be a participant in the regional TAP program to minimize fare change impacts.

3.8 Alternative Service Delivery Options

Alternative service delivery options generally refers to services not directly operated by Metro, such as contract services, Municipal and Local Return Operators, taxis and other flexible destination operations. These alternatives can complement traditional transit service. In addition, Access Services provides mandatory ADA complimentary paratransit services for functionally disabled individuals in Los Angeles County. Access transportation service is available for any ADA paratransit eligible individual to any location within $\frac{3}{4}$ of a mile of any fixed bus operated by the Los Angeles County public fixed route bus operators and within $\frac{3}{4}$ of a mile around Metro Rail stations during the hours that the systems are operational. Complimentary paratransit service is not required to complement commuter rail and commuter bus services, since the ADA does not require that these services provide complementary paratransit service.⁵

Metro has launched two pilot programs to leverage demand-responsive technology to improve mobility, customer experience, and system performance by providing additional first-mile and last-mile service options: Mobility on Demand and MicroTransit.

The Mobility on Demand pilot launched in January 2019 and will operate for 12 months. Metro has partnered with Via, a provider of on-demand shared rides, to develop on-demand technology to increase access to Metro's transit system by offering service to and from three of Metro's transit stations: North Hollywood, Artesia, and El Monte. This pilot program is funded in part by a \$1.35-million Mobility on Demand (MOD) Sandbox Demonstrations grant from the Federal Transit Administration (FTA).

The MicroTransit Pilot Project is anticipated to launch in late 2019. Metro is partnering with RideCo, NoMad/Via, and Transdev to develop on-demand technology to increase access to Metro's transit system. MicroTransit short trips will be approximately 20 mins in vehicle and run one to five miles in distance. These short trips may connect customers to Metro operated services and to municipal operators.

⁵ https://accessla.org/riding_access/overview.html

SECTION 4: CUSTOMER INFORMATION AND AMENITIES

Customer information instructs both regular customers and infrequent customers on how to use transit as a viable mode of transportation to and from their destinations. Clear, accurate, and timely information is an important adjunct to service quality, particularly when bus and rail services are not operating as planned. Amenities aid in the comfort and security of customers.

4.1 Customer Information

Customers need to know how to use transit: where to go to access it, where to alight to access their destination, whether transfers are required, when transit services are scheduled to depart and arrive, and how planned and unplanned service changes or disruptions impact travel. Both regular and infrequent users require specific route information when they need to travel to a location they rarely visit or that is new to them. Information must be provided in accessible formats. Metro provides customer trip planning and help information via telephone, customer service representatives, on-board announcements, mobile device applications and text/SMS messaging, by mail, online at the metro.net website, and by email.

- **Signage** at transit infrastructures such as stations and shelters, signs directing motorists to Park & Ride lots, and bus stop signs that indicate the presence of service to people not currently using transit.
- **Audible Announcements** at bus stops, rail stations and on-board vehicles to assist customers with visual impairments and customers unfamiliar with the route or area.
- **Online Information** is available 24-hours to anyone with Internet access such as:
 - Nextrip’s next bus arrival (detour notices should be posted on this service, Metro’s website, as well as other transit applications)
 - Google, Apple, and Bing Maps
 - Route maps and timetables, fare information, and Trip Planner
 - Specialized guides (Bikes, Riders with Disabilities, Safety & Security)
 - Commuter program information (carpools, vanpools, employer programs, etc.)
 - News and media information
 - Latest projects and programs
 - Contact information
 - Special event information
 - Social media accounts
- **Bus and Train Real-Time Information:** Accurate, timely, relevant, and readily available trip information is useful for reassuring customers when the next transit vehicle will arrive or how long the expected delay time is if there has been a service disruption. It should provide them with enough information to help them decide whether to continue to wait for the next transit vehicle, consider alternate routes, or take another mode of transportation to complete their trip.
- **Printed and Distributed Information**, such as timetables, maps, service change notices, customer newsletters, etc., preferably available at multiple locations.

- **Posted Information**, such as system maps, bus cubes posted at stops, stations, and on board transit vehicles.
- **Route Numbering Convention** at stops and on transit vehicle head signs assist customers to quickly identify what stops to wait at and what transit vehicle to board related to printed and posted information. See Appendix A.
- **Wayfinding** is the process of communicating information to support the ability to navigate using signage, system/route maps, kiosks, bus cubes, directions, etc. so that customers can easily determine where they are, where they want to go, and how to get there.
- **Visual Displays** to assist customers with hearing impairments and to supplement on-board announcements that may be muffled by other noise.
- **Customer Information Panels (CIPs)** are interactive touch screen panels that display vehicle arrivals, service alerts, system and local maps, Metro Arts programming, advertising, and Agency PSAs.

4.2 Customer Amenities

Customer amenities are those elements provided at a transit stops, transit centers, and station stops to enhance comfort, convenience, and security. Amenities include items such as shelters, benches, vending machines, trash receptacles, lighting, restrooms, and telephones. In some instances, Metro coordinates with municipalities to provide appropriate amenities. Metro provides a minimum set of customer amenities at all rail stations and major Metro-owned off-street bus facilities that allow for boarding as summarized in Table 4.1.

- **Benches** provide comfort for waiting customers, help identify the stop or station, and provide an affordable alternative to shelters.
- **Elevator/Escalators** provide accessibility for those who otherwise cannot use stairs to elevated or lowered station stops.
- **Lighting** increases visibility, security, and discourages misuse of bus stops when transit operations are not in service.
- **Public Restrooms** may be provided at major transit centers and maintained for public safety and convenience.
- **Shelters** provide comfort for waiting customers, protection from climate conditions, and help identify the stop or station. Metro does not own or install benches and shelters but will coordinate with local jurisdictions on their placement where appropriate.
- **Telephones/Intercoms** provide access to transit information and emergency services.
- **Trash receptacles** provide a place to discard trash and contribute to keeping bus stops and surroundings clean. Trash receptacles are placed and maintained by individual municipalities at bus stop locations.

Table 4.1 *Customer Information and Amenities*

Amenity	Service Type	Allocation
Shelters:	Heavy Rail:	n/a
	Light Rail:	At least 80 linear ft. per bay
	Bus Facilities:	At least 6 linear ft. per bay
Seating:	Heavy Rail:	At least 12 seats
	Light Rail:	At least 10 seats
	Bus Facilities:	At least 3 seats per bay
Info Displays:	Heavy Rail:	At least 12
	Light Rail:	At least 10
	Bus Facilities:	At least 3
LED Displays:	Heavy Rail:	At least 8 arrival/departure screens
	Light Rail:	n/a
	Bus Facilities:	n/a
TVMs:	Heavy Rail:	At least 2
	Light Rail:	At least 2
	Bus Facilities:	n/a
Elevators:	Heavy Rail:	At least 2
	Light Rail:	At least 1 for elevated/underground
	Bus Facilities:	At least 1 for multi-level terminals
Escalators:	Heavy Rail:	At least 4 (2 Up/2 Down)
	Light Rail:	n/a
	Bus Facilities:	n/a
Trash receptacles:	Heavy Rail:	At least 6
	Light Rail:	At least 2
	Bus Facilities:	At least 1 per 3 bays/2 per facility

4.3 Rail Stations and Major Off-Street Bus Facilities

When transit service is not provided near one’s origin, driving to a Park & Ride lot or utilizing another first-last mile option such as a bicycle or scooter to transit may be viable alternatives. Park & Ride lots, bicycle storage, and micro-mobility parking areas are important amenities for transit customers.

- **Park & Ride/Station Parking Facilities** provide parking for transit customers who use their cars to access a bus or train. Park & Ride facilities are usually provided at station stops or transit centers such as the Metro El Monte Station, Harbor Gateway Transit Center, and at various rail stations. Park & Ride lots also can be found in suburbs to serve as a staging area for commuter customers.

- **Bicycle Storage** may be provided at transit stations where demand exists and space allows, and on transit vehicles. Bicycle racks, lockers, and hubs may be provided at transit center and stations. On transit vehicles, bicycles may be transported on bus-mounted racks located in front of a bus or on board a rail car in designated spaces. Bike racks provide a simple, relatively low-cost approach and can hold many bicycles in a relatively small space, but bicycles are subject to potential damage and theft. Enclosed bicycle lockers and hubs provide added protection from theft and from weather but cost more and require more space.
- **Micro Mobility Vehicle Parking** is being tested at key Metro system locations as a pilot program. At their July 25, 2019 meeting, the Metro Board adopted a parking ordinance to regulate parking of electric scooters and other similar devices. As part of the pilot, Metro has designated parking areas at select stations and transit hubs for parking of devices; the private firms seeking to park their vehicles at Metro sites must pay a fee for use of the parking facilities.⁶

4.4 Bus Stop Amenities

There are no standards for bus stop amenities because apart from painting the curb red and erecting bus stop signage, Metro has no jurisdiction over street-sitting fixtures or other appurtenances; those are installed by the municipality where the stop is located and often contracted to third parties who support installation and maintenance through advertising revenues.

Transit services are supported by bus stop, transit center and stations facilities. These locations are often the first and last points of contact with the customer. These facilities are an essential component of transit infrastructure that direct customers to existing transit services, provide a safe and comfortable environment in which to wait for service, and facilitate safe and efficient transfers between services. Given their importance, it is vital that transit routes and schedules are developed in consideration of the quality, appropriateness, and availability of facilities.

Bus stops are locations along the route of a bus line where customers safely wait to board or alight from a bus in service. Bus stops consist of a pole with a sign that includes route line number, destination and service qualification signage, and curb markings or parking restriction signage. Select bus stops also include a bus information cube affixed to the pole. Most bus stops are located along the curb of a street; others are located at offsite facilities such as transit centers or rail stations that are owned and maintained by the local municipality or by Metro.

Transit stations are stops along a fixed guideway and have features such as loading platforms, TVMs for fare pre-payment, shelters, benches, lighting, information displays, trash receptacles, bike racks and lockers, and emergency call boxes. Many are located adjacent to Park & Ride lots and customer pick-up/drop off areas.

⁶ Planning and Programming Committee File #2019-0085; LACMTA Administrative Code Title 8: Metro Parking Ordinance

Transit centers are high volume transfer points for multiple transit services and layover spaces for end-of-line bus storage and turn around. Features include customer loading and alighting areas, benches, shelters, lighting, information displays, bicycle racks and lockers, trash receptacles, and bus layover bays.

On-street bus layover zones are designated stopover points for buses at or near the end of the line. They may or may not allow for customer boarding and alighting. Bus terminals are major offsite layover areas for multiple bus lines and may or may not allow for customer boarding and alighting.

Locating bus facilities (other than on-street stops) in heavily congested or urbanized areas increases the burden on the transit operator to find layover spaces for buses and operator restrooms. The extension of a line to a specific terminal may prove uneconomical and at the very least add costs to an already budget constrained operation.

Cost and minimization of customer disruptions are significant concerns when locating facilities for bus operations. Metro Operations continues to evaluate routes and layovers to reduce costs and improve efficiency. As a key internal stakeholder in the environmental planning process, the Service Development Department should be involved early in the analysis of alternatives to and the development of mitigation measures to ensure adequate accommodations are incorporated to foster connectivity of future projects.

Capital costs of new support facilities are an important determinant; but more significant is the added operating cost that may be incurred due to inadequate facilities.

4.5 Bus Stop/Station Location, Design and Guidelines

Bus stops and station stops allow for boarding and alighting of customers; their locations should balance safe, convenient access with pedestrian safety. Locations should support efficient transfers, minimize walking distances and unnecessary crosswalk movements, and preferably be located at a signalized crosswalk to prevent potential jaywalking. Bus stops are generally located adjacent to a bus/rail station or within a short walk to medical facilities, schools, shopping centers, office buildings, multi-unit apartments, or other major activity centers to provide access for uses that generally attract transit customers. Hospitals and schools have high priority when considering new bus stop locations and/or when relocating existing bus stops.

BRT/Rail station locations are determined during the design phase of a fixed guideway/right-of-way. There are criteria associated with station location, but this is beyond the scope of this TSP. Generally, stations are located at major transfer points with bus or rail and provide access to major activity centers. No standard type of stop can be recommended for all locations, as each intersection has its own unique characteristics. An inventory of land uses that serve as major trip producers and attractors within a 0.25-mile corridor of the road under consideration should be taken prior to establishment. The location of a transit stop requires concurrence of the municipality in which the stop is located in.

In general, far-side stops are preferable, particularly at signalized intersections; however, near side or mid-block stops may be justified in certain situations. A summary of advantages and disadvantages to each location are provided in Table 4.2. TCRP Report 19 “Guidelines for the Location and Design of Bus Stops” (1996) provides a more detailed discussion.

Table 4.2 *Comparative Analysis of Bus Stop Locations*

Stop Type	Advantages	Disadvantages
Near-Side	<ul style="list-style-type: none"> ▪ Minimizes interference when traffic is heavy on the far side of the intersection ▪ customers access buses closest to crosswalk ▪ Intersection available to assist in pulling away from curb ▪ Buses can service customers while stopped at a red light ▪ Provides driver with opportunity to look for oncoming traffic including other buses with potential customers 	<ul style="list-style-type: none"> ▪ Conflicts with right turning vehicles are increased ▪ Stopped buses may obscure curbside traffic control devices and crossing pedestrians ▪ Sight distance is obscured for crossing vehicles stopped to the right of the bus. ▪ The through lane may be blocked during peak periods by queuing buses ▪ Increases sight distance problems for crossing pedestrians
Far-Side	<ul style="list-style-type: none"> ▪ Minimizes conflicts between right turning vehicles ▪ Provides additional right turn capacity by making curb lane available for traffic ▪ Minimizes sight distance problems on approaches to intersection ▪ Encourages pedestrians to cross behind the bus ▪ Requires shorter deceleration distances for buses ▪ Gaps in traffic flow are created for buses re-entering the flow of traffic at signalized intersections ▪ Allows bus routes that operate signal priority to take advantage this technology at signalized intersections. 	<ul style="list-style-type: none"> ▪ Intersections may be blocked during peak periods by queuing buses ▪ Sight distance may be obscured for crossing vehicles ▪ Increases sight distance problems for crossing pedestrians ▪ May increase number of rear-end accidents since drivers do not expect buses to stop again after stopping at a red light
Mid-Block	<ul style="list-style-type: none"> ▪ Minimizes sight distance problems for vehicles and pedestrians ▪ Passenger waiting areas experience less pedestrian congestion 	<ul style="list-style-type: none"> ▪ Requires additional distance for no-parking restrictions ▪ Encourages customers to cross street at mid-block (jaywalking) ▪ Increases walking distance for customers crossing at intersections and for transferring customers

Source: FTA webpage (http://www.fta.dot.gov/12351_4361.html)

When two or more bus routes operate along the same corridor, stops should be consolidated to avoid unnecessary crosswalk movements and minimize confusion as to which stop customers should wait to catch their bus wherever possible. However, if a group of bus lines operating along the same street, in the same direction, serving the same intersection (such as in the downtown environment), it may be necessary to implement two stop locations (e.g.

nearside and farside) to minimize congestion and negatively impact bus operations under the following circumstances:

- Some bus lines will queue up to make a right turn while other lines continue through the intersection (unsafe right turn movements)
- Lack of space availability and no room to lengthen zone due to business owner objection, jurisdiction refusal to extend, a loading zone being located behind the current stop, etc.)
- Bus Stop/Station Accessibility: All stops and stations should be fully accessible in accordance with the 1990 Americans with Disabilities Act. This includes ensuring there are no obstructions preventing the boarding and alighting of customers who use a wheelchair or other assistive mobility devices, and that pathways to and from a stop or station are unobstructed. If obstructions do exist, every effort must be made to mitigate the issue(s) with the respective municipalities. In the case of bus stops, they can either be moved to a new location on a permanent basis or temporary basis depending on situations, such as during construction.

The following renderings (Figures 4.1 – 4.4) illustrate a typical bus stop/zone design and offers guideline for near-side, far-side, and mid-block locations. TCRP Report 19 “Guidelines for the Location and Design of Bus Stops” (1996) provides a more detailed discussion.

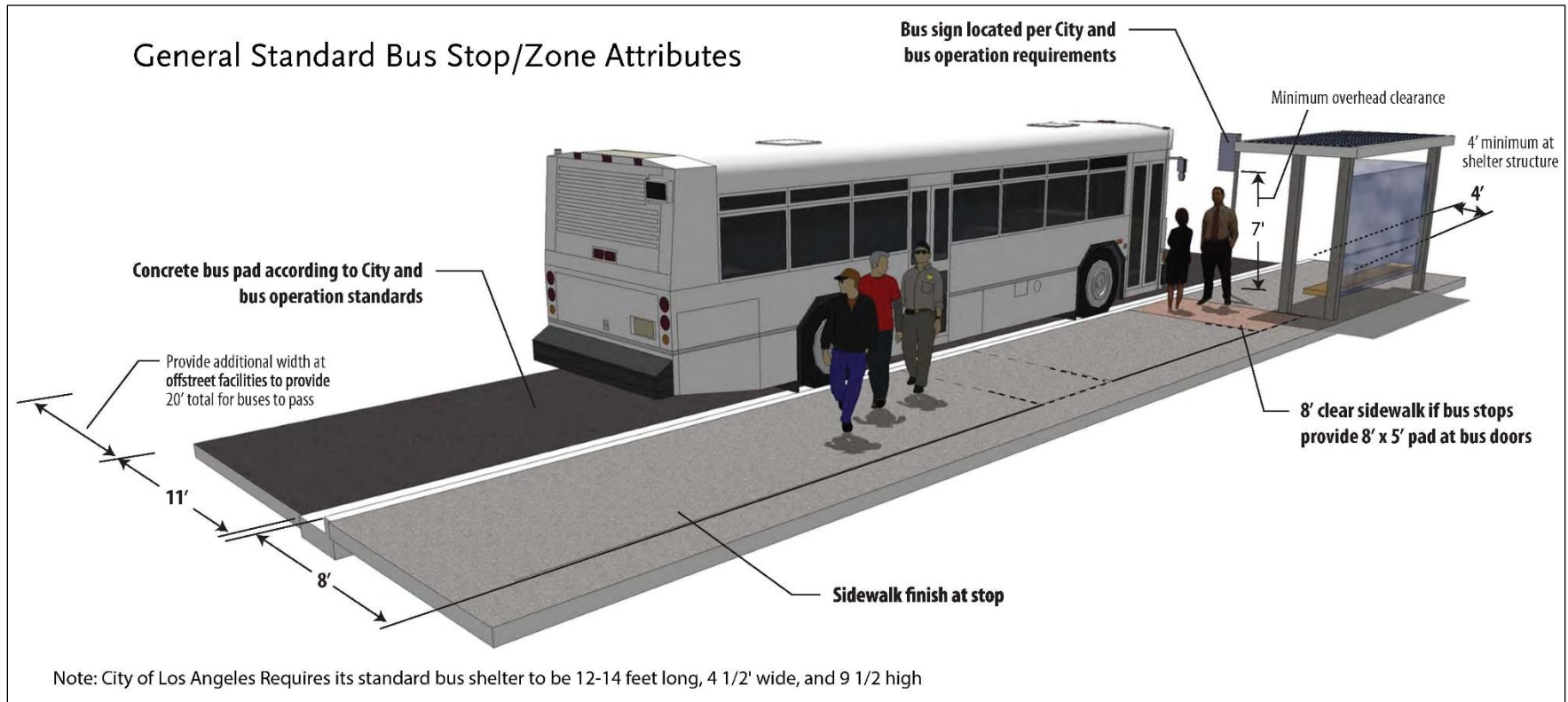

Figure 4.1 General Standard Bus Stop/Zone Attributes

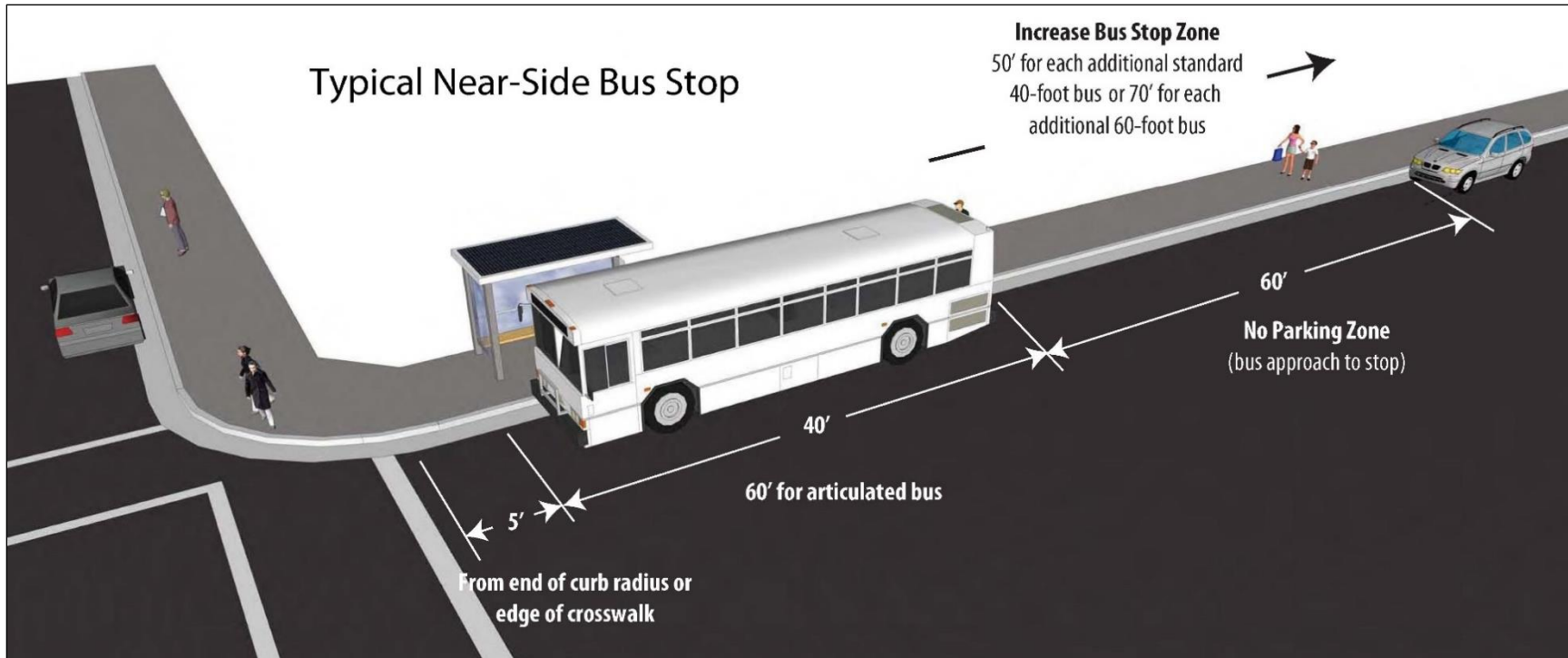

Figure 4.2 Typical Near-Side Bus Stop

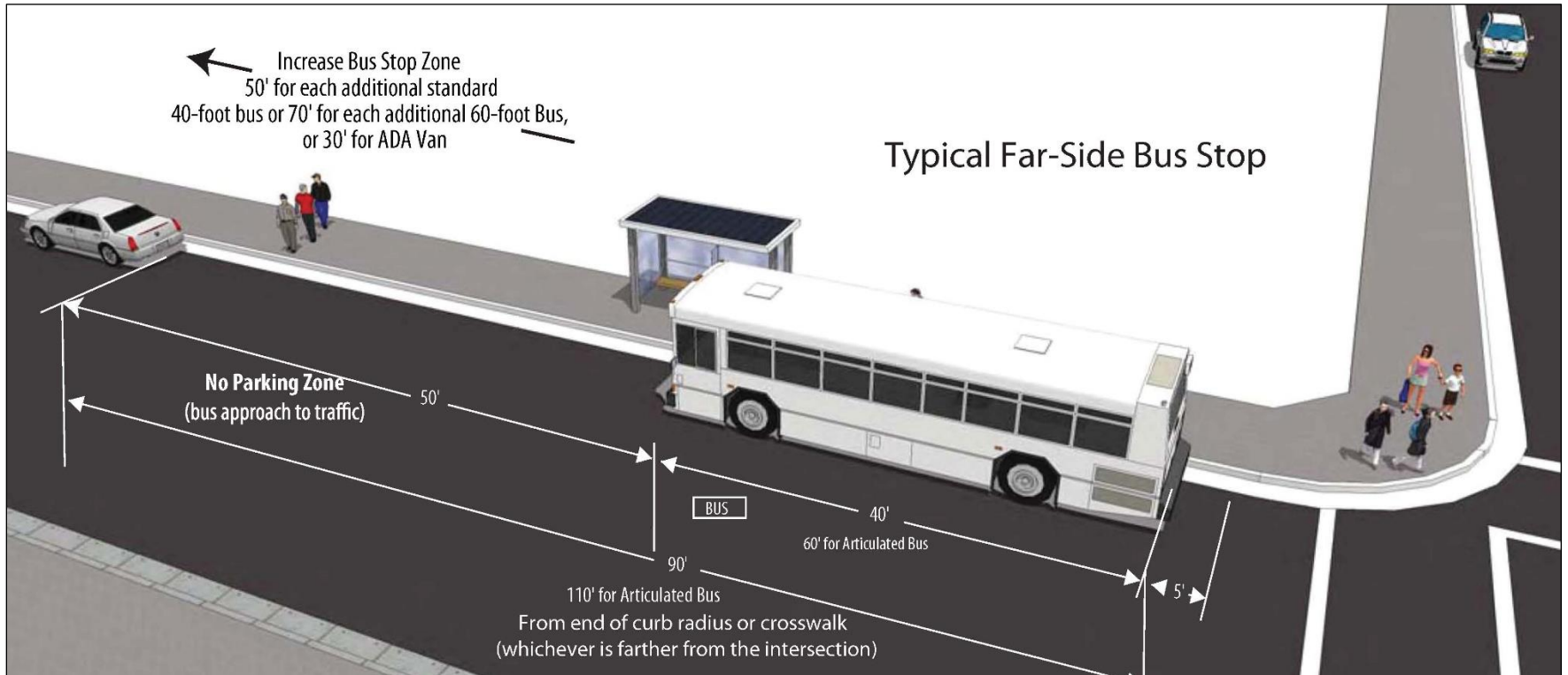

Figure 4.3 Typical Far-Side Bus Stop

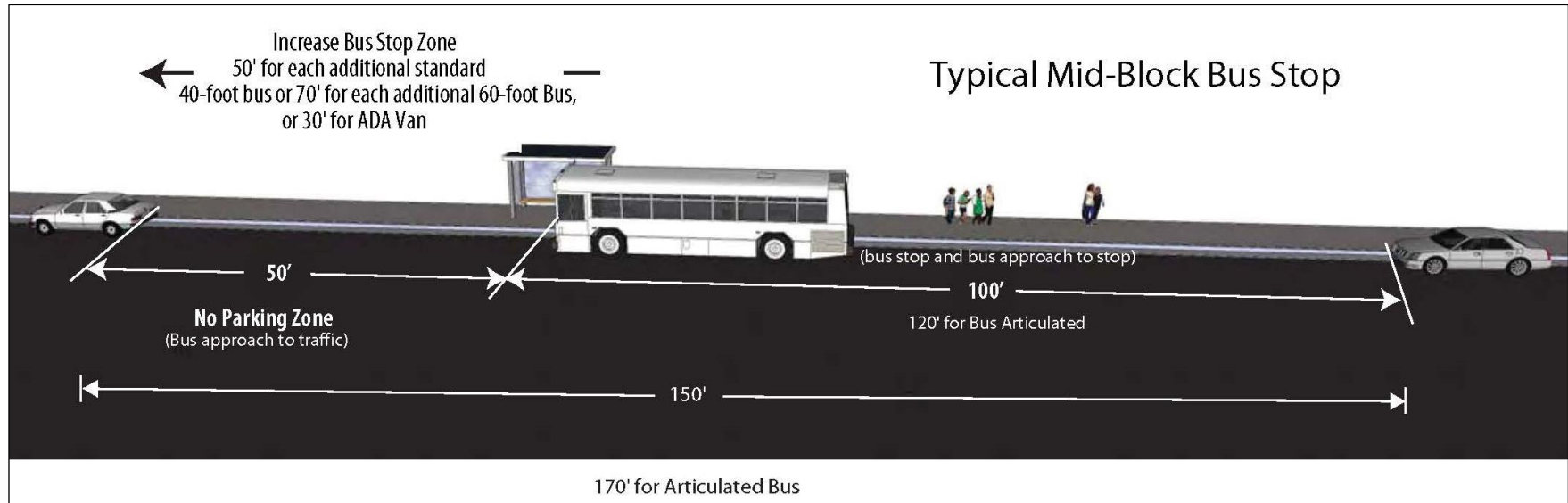

Figure 4.4 Typical Mid-Block Bus Stop

SECTION 5: SERVICE PERFORMANCE EVALUATION

The 2019 Metro TSP establishes a set of performance criteria and standards that balances optimization for efficiency and productivity with customer experience measures of success. Optimization of key performance indicators ensures that the services being provided generate the maximum benefit in terms of ridership at the lowest cost. Customer experience criterion measure how well the transit system can attract customers to use the system more often and for new trip purposes.

5.1 Route Performance Index

The Route Performance Index (RPI) is a conventional industry measure used to ensure Metro services are effective and provide a reasonable return on investment. The RPI is designed to provide an objective measure of bus route performance relative to system performance. The index is based on system ridership and financial targets from the current fiscal year Metro Budget.

This measure is applied to all Metro bus lines that have been in operation for more than one year. The RPI is used to identify under-performing lines. Specific corrective actions are taken during the service change process. Corrective actions may include marketing, service restructuring, implementing an alternative service, or discontinuation of service.

Defining RPI Variables

The RPI considers the following three variables in creating the index. No weight is given to an individual measure; rather the selected statistics represent all facets of the operation in terms of cost efficiency, service effectiveness, and customer use.

- **Utilization of Resources:** Passenger Boardings per Revenue Service Hour (RSH) is used as a measure to determine how effectively resources are used on a given line. This measure is determined by dividing the total number of boardings by the RSHs operated. A route having a higher number of boardings per RSH represents a better utilization of resources such as buses, operators and fuel.
- **Utilization of Capacity:** Passenger Miles per Seat Mile is the measure used to evaluate how the seating capacity of the system is being used. Passenger miles are calculated by multiplying the average distance traveled per customer by the number of customers using the service. Seat miles are calculated by determining the number of seats per vehicle by the number of service miles operated. A higher resulting number indicates greater utilization of system capacity.
- **Fiscal Responsibility:** Subsidy per Passenger is the measure for fiscal responsibility. Subsidy refers to the amount of public funding required to cover the difference between the cost of operation and the customer revenues collected. Higher subsidy services require more public funding support.

The formula for calculation of the RPI for each Metro Bus line is as follows:

$$\text{RPI} = ((\text{Passengers/RSH/System Avg.}) + (\text{Passengers Miles per Seat Mile/System Avg.}) + (\text{Subsidy per Passenger / System Avg.}))/3$$

Lines with an index of 1.0 perform at the system average, while lines with an index of less than 1.0 perform below the average. Lines with an RPI lower than 0.6 are defined as performing poorly and targeted for corrective action. Lines that have been subjected to corrective actions and do not meet the 0.60 productivity index after six additional months of operation may be discontinued, subject to Metro Service Council and Board approval.

The RPI is calculated and reported quarterly by Metro's Service Planning & Scheduling Department. The performance measurement standards for each route are set annually relative to the percentage improvement of overall system performance relative to the previous year's performance. This percentage improvement will be based on the performance objectives outlined in the Metro Annual Operating Budget.

5.2 Customer Experience

Providing high quality mobility options that enable people to spend less time traveling on the transit network requires that we are available when and where our customers want to travel, we are competitive enough to have them try us over other options, and we are attractive enough to ensure they return for the same trip and ideally for more trips. Therefore, our recommended measures of success are aimed at evaluating the bus network within these three stages of Find, Try, and Rely. These customer focused measures help to balance our traditional metrics of productivity and efficiency (e.g. ridership, boardings per hour, subsidy per boarding). Several of these measures (italicized below) will be used to evaluate the network through the lens of equity.

Find - How well do people understand how effectively transit can serve their needs? Is the system easy to understand and use? Proposed measures include:

- Services and information is Readily Available
 - Percentage of trip ends within ¼ mile of transit stop
 - Trip planner, app, and website usage rates
 - *Percent of public considering transit (survey-based)*
- The Bus System is Easy to Understand and Use
 - Percentage of out of direction travel
 - Percentage of route miles with all-day frequent service (<15 min headways)
 - *Percent of public understand how to use system (survey-based)*

Try - How can we encourage customers to try the regional transit system? (Metro and Municipal Bus Operators) Proposed measures include:

- Bus Goes Where/When Customers Want
 - *Percentage of trips compatible with transit by time of day and day of week*
 - *Number of jobs and activity centers accessible within a 15 minute and 30 minute transit ride*
 - Number of unique transit users

- Bus system is Competitive
 - *Door-to-door travel times*
 - *Competitiveness of transit time to drive time*
 - System-wide boardings
- Coverage is Adequate
 - *Population within ¼-mile of transit stops by frequency of service*
- Transit Journeys are Simple
 - Average number of transfers
 - Percent of trips that are one-seat rides

Rely - How can we provide services that customers can rely on for their travel needs? Proposed measures include:

- Bus System is Effective and Productive
 - *Competitive transit paths for short, evening, midday, and weekend trips*
 - Number of frequent customers
 - Boardings by time of day and day of week
 - Boardings per revenue hours and miles
 - Cost per passenger mile
- Buses are Reliable
 - Headway regularity on frequent routes
 - On-time performance
 - Real time arrival accuracy
- Customers are Satisfied
 - Rides per week for frequent and infrequent users
 - *Percentage of customers satisfied with Metro services (survey-based)*

5.3 Service Evaluation Process

Services are evaluated monthly, quarterly, and biannually based on the network, lines and segments (geographic, time of day, and day of week) . Services that are inconsistent with demand or do not meet system standards are identified for restructuring, reduction, or discontinuation. Services that have potential for exceeding existing performance will be identified for possible enhancements as should markets that are currently not well served. The following priorities will be considered when restructuring the Metro system:

- **Priority 1** – Restructure services to increase system speed, on-time performance, and balance loads.
- **Priority 2** – Restructure services that are duplicative with Metro Rail, other Metro Bus routes, and Municipal and Local Return operator services. Such services will be identified for discontinuation, consolidation, reduction and/or reallocation to achieve greater productivity and cost efficiency.

- **Priority 3** – Restructure remaining services (constrained by existing budget) based on the service concept and to address major gaps and deficiencies. Prioritize these service adjustments.
- **Priority 4** – Develop new services (unconstrained) to address all gaps and deficiencies. Prioritize these new services.

Significant changes to municipal operator services are incorporated into the evaluation of existing and new services as possible enhancements to address identified gaps or deficiencies in service.

Service Change Performance Evaluation

Schedule adjustments to bus or rail should be evaluated shortly after implementation to determine if there are any obvious issues. This should include line rides and visits to the operating divisions to receive comments and recommendations from customers, operators and supervisors. Appropriate adjustments should be made as required. After three months of operations, the schedules should be evaluated in detail to begin the process of schedule adjustments for the next service change cycle.

Route modifications to bus service should also be evaluated shortly after implementation like the schedule evaluation outlined above. The overall goals of the service changes such as reducing costs, improving connections, increasing bus speeds, and increasing ridership, among others, should have near term goals that are established prior to the service change process. At about 6 months after service implementation, the performance of the changes should be evaluated relative to the established goals. Remedial actions, if necessary, should be developed and considered for the next service change cycle.

SECTION 6: SERVICE CHANGE PROCESS

In 2003 Metro created five localized service areas (Figure 6.1), each to be overseen by a Governance Council. In 2011, Metro restructured and re-established a centralized bus-controlled operation to include the service planning and scheduling function, while maintaining the authority and responsibility of the Councils to help coordinate service changes. Metro restructured the roles and responsibilities of the Governance Councils, now referred to as Service Councils.

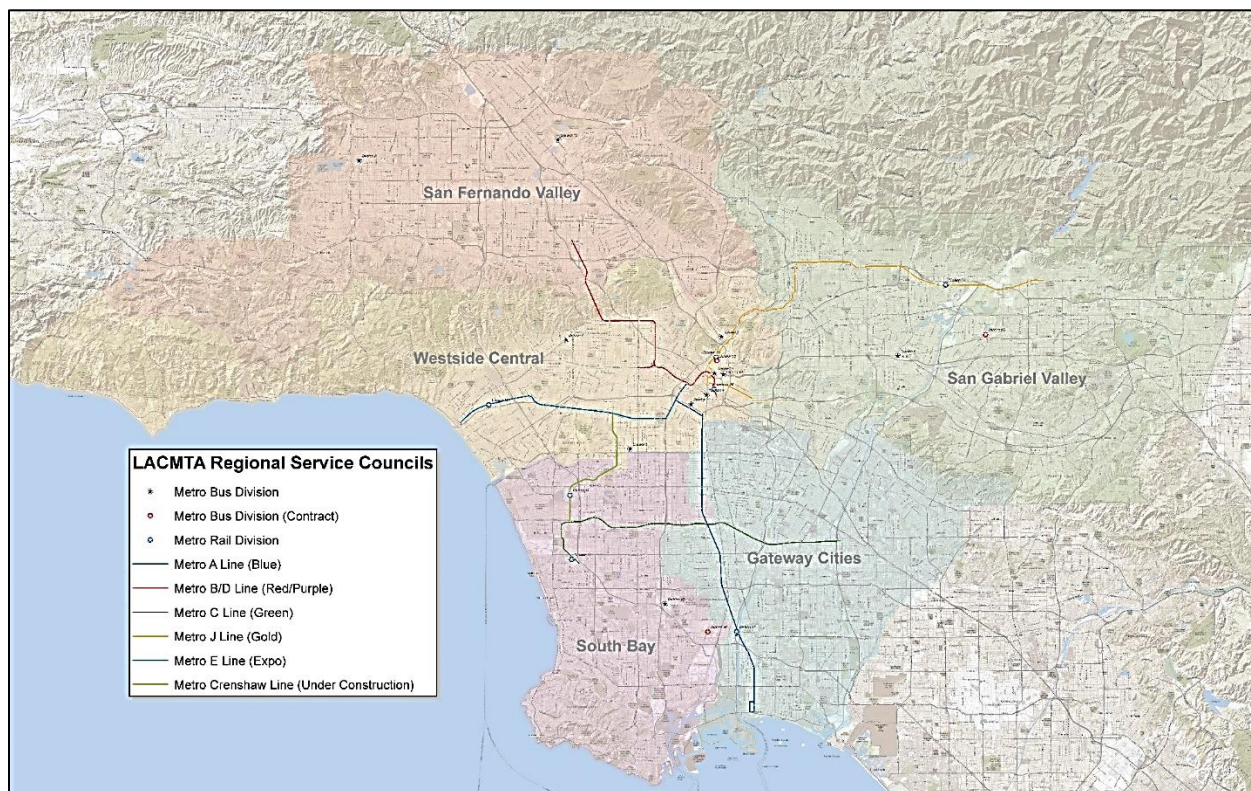

Figure 6.1 *Metro Service Council Areas*

Metro Service Councils provide locally accessible public forums for community members, transit users, and local municipal operators to voice concerns, suggestions, and questions on how Metro can best serve customers. Through these forums, Service Council members can:

- better understand customer needs and make recommendations;
- evaluate opportunities and service coordination issues;
- advise and approve the planning and implementation of service changes within their areas.

As stated in the 2011 update to the Service Council bylaws, one of the Service Council's primary responsibilities is to render decisions on proposed bus route changes considering staff's recommendations and public comments. Metro Service Councils (MSC) will be responsible for approving all proposed permanent route changes, excluding turnaround and out of service route modifications, which exceed a cumulative \$100,000 annual operating cost change. All

major service level changes that require public hearings will be brought to the MSCs who will conduct public hearings then vote to approve, modify, or deny the service change proposals. Any significant temporary service change should be brought to the Council for their information but not approval.

Each MSC will be responsible for holding public hearings that relate to major service changes to Metro bus and rail lines that provide significant service within their Region, consistent with State and Federal laws and with Metro policies pertaining to public hearings. Following receipt of public input, the Councils is responsible for approving all major service changes that are to be implemented that modify, add or delete Metro bus routes within the Service Council's jurisdiction in conformance with Metro service standards, collective bargaining agreements and Metro policies. When a major service change program requires three or more Councils to hold public hearings, an additional hearing will be held at a central location, normally at the Metro headquarters building, on an appropriate Saturday.

Table 6.1 *Service Change Timeline*

Key Activities	Required Lead Time (Months Prior to Implementation)
Initiate Planning Process	12
Develop Preliminary Recommendations	7-8
Impact Analysis for Proposed Changes	6-7
Title VI Equity Analysis on Major Service Change and Fare Change Proposals	5-7
Service Council Review and Input	6-7
Confer with Labor Relation and Union Representatives	6-7
Public Review and Input	5
Finalize Service Change Program	4-5
Program Approval	3-4
Develop New Service Schedules	2-4
Print Public Timetables and Operator Assignments	1-2
Fabricate Decals for Bus Blades	1-2
Take Ones/Rider Alerts on Buses	1

All route and major service changes that are approved by the MSC will be brought to the Metro Board of Directors as an information item. Should the Metro Board decide to move a Service Council approved service change to an Action Item, the Service Council will be notified of this change, prior to the next Service Council monthly meeting. Table 6.1 provides the established service change timeline.

6.1 Service Change Programs

Service change programs are developed based on input generated by a wide variety of sources including customer and employee input, service restructuring studies, requests from other local operators, and performance monitoring results. The service change process includes public review of the proposals, a technical evaluation of ridership impact, and Title VI equity analysis. In accordance with contractual agreements with the Sheet Metal Air, Rail and Transit Union (SMART)⁷, bi-annual service changes will be implemented in June and December. Metro service changes are conducted to modify service based on customer demand, running time adjustments, performance monitoring results, and budget considerations. A service change process workflow is provided in Figure 6.2.

Other factors considered are service performance, availability of alternatives, and mitigation strategies. As part of the evaluation process, resource impacts to in-service hours and required vehicles are also tracked to ensure compliance with budget parameters. In summary, the purpose of an evaluation on proposed service changes is to:

- Define and evaluate the impact on customers
- Determine whether a proposed major service change or fare increase will have disparate adverse impact on minorities or a disproportionate burden on low-income individuals by performing a Title VI Equity Analysis
- Consider alternatives if a disparate adverse impact to minorities or disproportionate burden on low-income individuals are identified
- Develop appropriate mitigation measures if needed
- Determine whether a public hearing is required

Changes to the rail system occur less frequently. They generally relate to the opening of a new line or adjustments to the frequency or hours of operation for existing service. Changes in rail and bus service follow the same planning and implementation process.

6.2 Title VI and Metro's Equity Platform

Metro's Equity Platform was adopted in February 2017. The framework for equity begins with Title VI of the Civil Rights Act of 1964 which protects minority and low-income communities from disparate and disproportionate negative impacts as a result of major transit service changes.

⁷ The United Transportation Union (UTU) merged with the Sheet Metal Workers Union in 2014 to form SMART.

Figure 6.2 Service Change Process

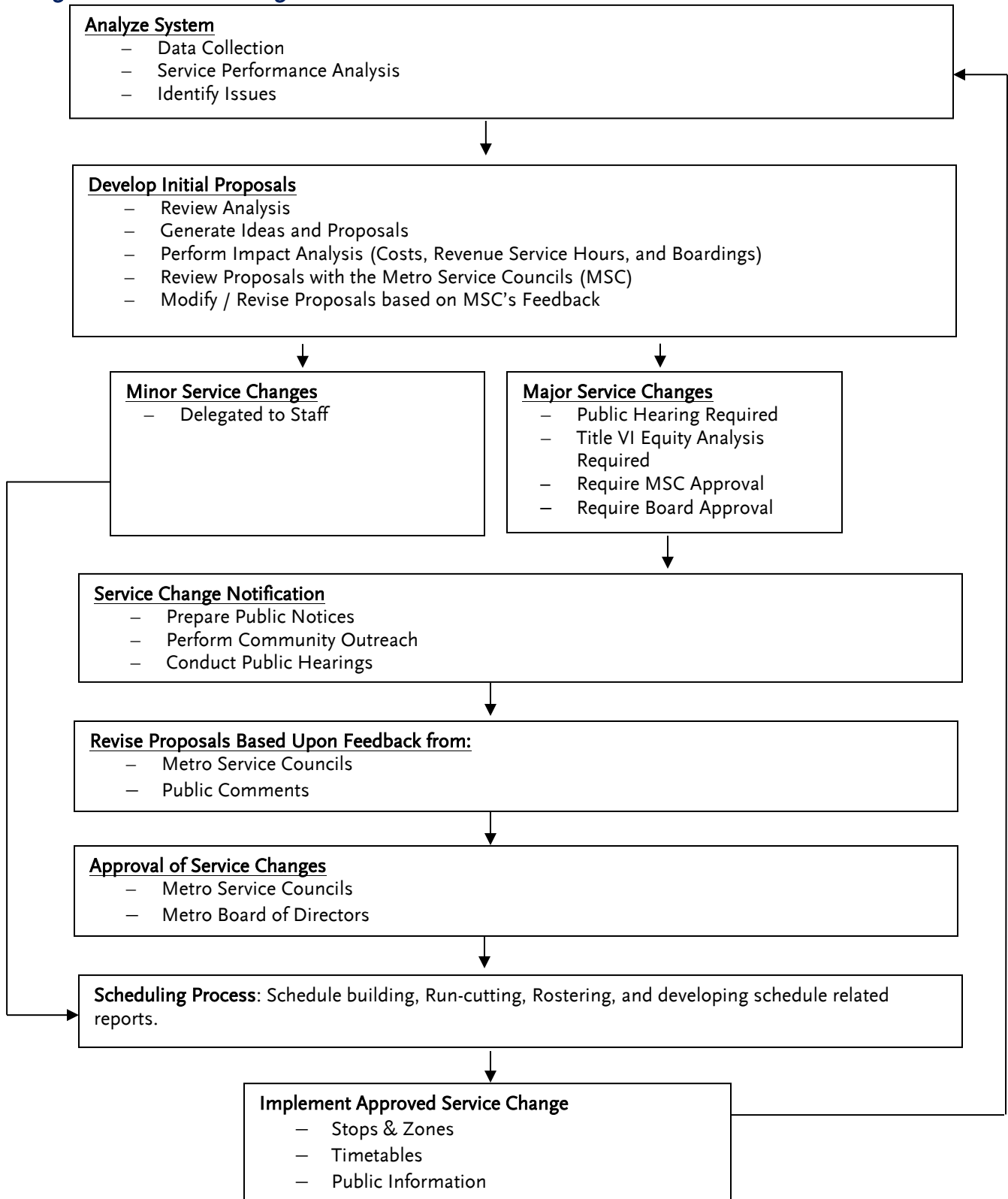

6.3 Title VI Equity Analysis

In addition, Metro will ensure a Title VI Equity Analysis is performed on all major service change and fare change proposals to determine if these proposals will have a disparate adverse impact on minorities or disproportionate burden on low-income individuals prior to a public hearing. If it is determined that these proposed changes will have a disparate adverse impact on minorities or a disproportionate burden on low-income individuals, Metro will make a good-faith effort to mitigate or reduce the adverse impacts by looking for alternatives.

The framework for equity begins with Title VI of the Civil Rights Act of 1964 which protects people from discrimination based on race, color, or national origin. Impacts on minority and low-income communities must be analyzed to identify disparate and disproportionate negative impacts resulting from a fare change or major transit service changes.

In accordance with FTA's Title VI Circular 4702.1B "Title VI Requirements and Guidelines for Federal Transit Administration Recipients" (Effective October 1, 2012), Metro's Administrative Code was revised to incorporate FTA's requirements under Title VI. The Metro Board adopted the updated Administrative Code in January 2013. Based on this Circular, Metro is required to perform a Title VI Equity Analysis on all proposed major service changes or fare changes prior to implementation. The goal is to ensure there is no *disparate adverse impact* to minorities or *disproportionate burden* on low-income individuals created by a major service or fare change. The following definitions and criteria were updated and adopted by the Board in September 2019. The Administrative Code now contains a reference to these definitions so that it need not be amended every time there is a need to modify the definitions:

Disparate Impact Policy:

Disparate impact refers to a facially neutral policy or practice that disproportionately affects members of a group identified by race, color or national origin and the policy lacks a substantial legitimate justification, including one or more alternatives that would serve the same legitimate objectives but with less disproportionate effects on the basis of race, color or national origin. This policy defines the threshold Metro will utilize when analyzing the impacts to minority populations and/or minority customers.

- a. For major service changes, a disparate impact will be deemed to have occurred if the absolute difference between the percentage of minority adversely affected and the overall percentage of minorities is at least five percent (5%).
- b. For any applicable fare changes, a disparate impact will be deemed to have occurred if the absolute difference between the percentage of minority adversely affected and the overall percentage of minorities is at least five percent (5%)

Disproportionate Burden Policy:

Disproportionate burden refers to a facially neutral policy or practice that disproportionately affects low-income populations more than those populations that are not low-income. A finding of disproportionate burden for major service and fare changes requires Metro to evaluate alternatives and mitigate burdens where practicable.

1. For major service changes, a disproportionate burden will be deemed to exist if an absolute difference between percentage of low-income adversely affected by the service change and the overall percentage of low-income persons is at least five percent (5%).
2. For fare changes, a disproportionate burden will be deemed to exist if an absolute difference between the percentage of low-income adversely affected and the overall percentage of low-income is at least five percent (5%)

Discretion of the Metro Board of Directors

A *major service change or fare increase* may be implemented even if the Title VI Equity Analysis determines a *disparate adverse impact* to minorities was created by the change. However, the Metro Board of Directors must first ensure these changes meet two tests:

- There is a substantial legitimate justification for adopting the proposed major service change or fare increase, meaning the selected service change or fare increase meets a goal that is integral to the mission of Metro; and
- The selected alternative would have a less severe adverse effect on Title VI protected populations than other alternatives that were studied.

Major Service Change

Major service changes are defined in Metro's Administrative Code in Chapter 2-50 Public Hearings Subsection 2-50-010 as any service change that meets at least one of the following criteria:

1. A revision to an existing transit route that increases or decreases the route miles and/or the revenue miles operated by 25% or more at one time or cumulatively in any period within 36 consecutive months since the last major service change;
2. A revision to an existing transit service that increases or decreases the scheduled trips operated by at least 25% at one time or cumulatively in any period within 36 consecutive months since the last major service change;
3. An increase or decrease to the span of service of a transit line of at least 25% at any one time or cumulatively in any period within 36 consecutive months since the last major service change;
4. The implementation of a new transit route that provides at least 50% of its route miles without duplicating other routes;
5. Six months prior to the opening of any new fixed guideway project (e.g. BRT line or rail line) regardless of whether or not the amount of service being changed meets the requirements in the subsections 1-5 above to be inclusive of any bus/rail interface changes.
6. Experimental, demonstration or emergency service changes may be instituted for one year or less without a Title VI Equity Analysis being completed and considered by the Board of Directors. If the service is required to be operated beyond one year the Title VI Equity Analysis must be completed and considered by the Board of Directors before the end of the one year experimental, demonstration or emergency.

7. A Title VI Equity Analysis shall not be required if a Metro transit service is replaced by a different route, mode, or operator providing a service with the same headways, fare, transfer options, span of service and stops.

Fare Changes

Any fare change requires an equity evaluation consistent with the following guidance:

1. A Fare Equity Analysis shall be prepared for any fare change (increase or decrease). This includes but is not limited to permanent fare changes, temporary changes, promotional fare changes, and pilot fare programs. The analysis will evaluate the effects of fare changes on Title VI protected populations and low-income populations. The analysis will be done for fares not available to the general public such as special discount programs for students, groups or employers.
2. If fare changes are planned due to the opening of a new fixed guideway project, an equity analysis shall be completed six months prior to opening of the service.
3. Each Title VI Fare Equity Analysis shall be completed and presented for consideration of the Board of Directors in advance of the approval of the proposed fare or fare media change by the Board of Directors. The Equity Analysis will then be forwarded to the FTA with a record of action taken by the Board.
4. A Title VI analysis is not required when:
 - a) A change is instituted that provides free fares for all customers;
 - b) Temporary fare reductions are provided to mitigate for other actions taken by Metro;
 - c) Promotional fare reductions are less than six months in duration. An equity analysis must be conducted prior to making any temporary fare change into a permanent part of the fare system.

6.4 Metro's Equity Platform

Metro's Equity Platform builds upon Title VI in two distinct ways. First, it goes beyond ethnicity and income to determine communities with the greatest mobility needs. Through market research, surveys, and public input, other groups most reliant on transit include non-English speaking new immigrants, youth and seniors, persons without access to an automobile either by choice or necessity, persons with disabilities, and women who tend to make more transit trips than men.

Second, NextGen Bus Study aims to go above and beyond Title VI, to not only protect against negative impacts, but to further improve service for communities with the greatest mobility needs. To do this, the Four Pillars of the Equity Platform have been integrated into the NextGen Bus Study planning and public engagement process.

- I. **Define and Measure** – Use Title VI as a baseline for identifying communities with the greatest needs, and supplement those with market research to identify the segments of population and trips with the highest propensity for transit use. Evaluate bus

network changes based on the customer focused performance metrics established within this report with particular focus on communities with the greatest mobility needs as identified above.

- II. **Listen & Learn** –The technical work of the NextGen Bus Study identified important information about Metro’s current and potential customers. This data was validated by the robust countywide public engagement effort, including engaging customers onboard buses, outreach sessions at community events, stakeholder briefings, interactive public workshops, digital engagement and print advertising. Comments received will be incorporated into the systemwide service design as well as individual route changes.
- III. **Focus & Deliver** – Service design concepts (discussed above) have been established to address the recurring themes identified from the public outreach and market research, including faster and more frequent service, better reliability and accessibility to key destinations, better connectivity particularly with the municipal operators, and improved perception of security on board buses and at bus stops. These concepts, described below, will be used to redesign the routes and schedules.

In addition, a Transit Propensity Index score has been developed and assigned to every Census Tract in Los Angeles County. This index score considers the various market segments likelihood to use transit, the transit orientation of the environment being served, and the travel demand within the area. Areas with high scores should be prioritized for high quality transit service.

Lastly, other customer experience enhancements such as improved security, accurate real time arrival information, cleanliness, and improved first/last mile service are critical to attracting customers to use transit.

- IV. **Train & Grow** – The Board adopted Transit Service Policy will be updated to reflect the Regional Service Concept as adopted by the Board, including the goals and objectives of the bus network, measures of success, route and network design concepts based on public input and data analysis, and framework for balancing tradeoffs in consideration of Metro’s Equity Platform. In addition, an annual monitoring program will be established to track the progress of achievement towards the goals and objectives, and to inform on necessary adjustments.

6.4 Public Outreach

Prior to a public hearing, several public outreach efforts are made so that the greatest number of customers may respond to the changes at either a public hearing or by submitting written comments at a hearing, or via email, mail, or fax. In accordance with Metro’s Administrative Code in Chapter 2-50 Public Hearings Subsection 2-50-025:

1. Any public hearing required by Section 2-20-020 shall be conducted as set forth in this section.
2. Notice of the hearing shall be published in at least one English language and Spanish language newspaper of general circulation and at least thirty (30) days prior to the date

of the hearing. Notice at least thirty (30) days prior to the date of the hearing shall also be published in the neighborhood and foreign language and ethnic newspapers as appropriate to provide notice to the members of the public most likely to be impacted by the proposed action.

3. Notice of the public hearing shall also be announced by brochures in English, Spanish and other appropriate languages on transit vehicles serving the areas to be impacted and at customer service centers.
4. To ensure that the views and comments expressed by the public are taken into consideration, MTA staff shall prepare a written response to the issues raised at the public hearing. That response should also include a general assessment of the social, economic and environmental impacts of the proposed change, including any impact on energy conservation.
5. The public hearing related to a recommendation to increase transit fares charged the public shall be held before the Board of Directors and any action taken to increase the fares charged the general public must be approved by a two-thirds vote of the members of the Board of Directors. The Board of Directors may delegate to another body or a hearing officer appointed by the Chief Executive Officer the authority to hold the public hearing related to a change in transit service.

Table 6.2 *Timeline for Public Notification Activities*

Activity	Months Prior to Service Change
Service Planning staff reviews preliminary proposals.	7
Metro Service Councils set dates of public meetings, publish hearing notices in local newspapers and send LEP and minority communities written notification to elected officials, other operators and key stakeholder groups. Confer with Labor Relations and Union representatives.	5-6
Service Planning staff provides information on proposed changes to the Metro Bus Operators Subcommittee and at quarterly meetings held with the region's municipal and local operators.	3
Communication Department posts information proposed changes on Metro's website.	5
Operations staff distributes meeting notices on board vehicles. Public outreach at key transportation centers, bus stops, and on-board customer interface occurs as well.	Minimum one month prior to public hearings
Metro Service Councils conduct public hearings.	4
Metro Service Councils approve final service change program.	3
Metro Board receives the Service Councils' approved service change program as a Receive and File item.	2
Communication Department prepares press releases on final program and program brochures are distributed on-board Metro vehicles and other outlets.	1

The distribution of information will include line number, line name, route change information, and/or fare change proposals. Other public outreach occurs at key transportation centers, bus stops, and bus and rail stations 30 days prior to the public hearing date. These efforts are made to reach and engage customers who may not have time to attend a public hearing and to inform them of alternative communication methods available to file public comments. Public participation in the public hearing process is an important step in assisting staff and Metro Service Councils in developing and approving final service change proposals. Table 6.2 provides a timeline for public notification activities.

6.5 Public Hearing Process

Once a Service Change Program has been developed by Metro Service Planning Staff, the Metro Service Councils are asked to set a date, time and place for their public hearings. During the period between publication of the hearing notices and public hearings, each Service Council is provided a detailed presentation on service change proposals and given an opportunity to discuss the changes that will be the subject of public comment. After each hearing, each Service Council will meet to consider and approve, modify, or deny all proposed service changes. These actions will then be summarized and presented in an informational report to the Metro Board of Directors.

Under Metro's Service Council by-laws, all service changes must be reviewed and approved by their respective Service Council(s). Public hearings are usually held at the same location where the Service Councils hold their meetings but may be held at other locations at their discretion. When a major service change program requires three or more Councils to hold public hearings, an additional hearing will be held at a central location, normally at the Metro headquarters building, on an appropriate Saturday. In accordance with Metro's Administrative Code in Chapter 2-50 Public Hearings Subsection 2-50-020, Metro will hold a public hearing on all major service change or fare change proposals that are subject to a Title VI Equity Analysis. These proposals are subject to Metro Service Council and Metro Board approval.

6.6 Implementing Minor Changes on an Interim Basis

Minor service changes are generally route modifications that can be accommodated without impacting the vehicle or operator requirements of the service. Minor service changes do not require a public hearing but are shared with the relevant Service Councils as a courtesy and can be implemented at the discretion of staff.

APPENDICES

APPENDIX A: Metro Line Identification

The purpose of establishing transit service line identification standards is to create a simple way for customers to identify, locate, and reference Metro services, and thereby make the services easier for customers to use.

The line identification standards shall be adhered to when identifying Metro Bus and Metro Rail lines by name. The standards shall be implemented across all internal and external mediums including but not limited to, rail station signs, bus stop signs, bus station signs, vehicle head signs, vehicle destination signs, timetables, the Metro Transit Trip Planner, HASTUS and ATMS⁸. The descriptions and chart below help explain the standards, and how and when they should be implemented.

General Standards

- Transit service lines will be identified using a combination of line number, destinations (both terminals) and the corridor(s) the line travels along. Metro Rail and Metro BRT service which previously used the established operational names (e.g., Metro Red Line, Metro Purple Line, Metro Orange Line) are being transitioned to names based on a letter designation. To ensure consistent usage of transitional naming for Rail and BRT lines, updates to customer information should be referred to the Communications Department.
- Acceptable destination names include a city, community, major landmark, transit center or rail station. Street intersections are no longer to be used as a destination, unless the intersection is required to identify short-line service.
- The destination points will be listed in a West to East or North to South order, consistent with how the line would be read on a map. Destinations on head signs, destination signs, timetables, and physical signage must always be consistent.
- Lines that have Downtown LA as one of the line's end points will list it first, as Downtown LA.
- The name of the line will also list at least one major corridor on which it travels.
- Name abbreviations, street extensions and other topics will be dictated by the Metro Signage Guidelines.

Printed Materials and Electronic Customer Information

- The line will be presented using the full name, listing both the destinations and major corridor(s).
- Printed materials include, but are not limited to, timetables, service change announcements, brochures, system maps, and service reports.

⁸ HASTUS (Horaires et Assignments pour Systems de Transport Urban et Semi-Urban) refers to the software used to create schedules. ATMS (Advanced Transportation Management System)

- Electronic customer information includes the line information presented on metro.net and underlying electronic databases such as HASTUS and ATMS.
- The Metro Transit Trip Planner will present the line name similarly to what will be shown on the vehicle head sign and bus stop sign, so customers can easily locate the appropriate line at the stop.

Rail Station Signage

- The line will be presented using the line letter designation, and destination point that the vehicle is traveling to in each direction.

Bus Stop Signage

- The line will be presented using the line number, service brand, color and destination point that the vehicle is traveling to in each direction.
- The main corridor(s) will also be listed as well as special service qualifiers including, but not limited to, rush-hour service and weekday-only service.
- Short-line trip destinations will not be shown on bus stop signs.

Vehicle Head Signs

- Head signs will list the destination in which the vehicle is traveling towards in one frame.
- Head signs on Rail and BRT vehicles will list the line letter designation in one frame.
- For short-line trips, the line number and destination shown will be the destination of that trip and not of the entire line.
- When the line is not in service, the sign will read “Not in Service” and display the route number per Operations Notice #09-18.

Automatic Voice Announcements

- External On-Board Announcements:
 - The line will be identified in automatic external voice announcements using the line number and destination point that the vehicle is traveling to in each direction.
 - For short-line trips, the destination noted will be the destination of that trip and not of the entire line.
- Internal On-Board Announcements:
 - When the automatic voice announcement system identifies a stop, the end destination of that line will follow.
 - The stops and stations announced onboard should be consistent with names used on maps, timetables and other printed materials.









Assigning Line Identifiers

It is expected that the standards will be easily applied to the majority of lines; however, it is also understood that exceptions will have to be made for some lines due to unfamiliar end points or corridors, or where temporary solutions are necessary due to construction, temporary service changes, or pilot program deployment. In these limited cases, Service Planning staff and Communications must be in consensus regarding these changes before deciding to deviate from the standards. The Stop and Zones Department may also deploy temporary signage at bus and rail facilities as needed when emergency closures or other service changes impact scheduled service. For detailed guidance on using Metro signage standards, Metro Signage and Environmental Graphic Design Standards documents may be obtained from the Communications Department.

Metro's Rail Line Identification, Naming, and Color Conventions

Rail and BRT lines previously denoted by a color will transition to a letter/color combination beginning in November 2019 when the Metro Blue Line reopens after an extended upgrade. Metro's BRT lines will also transition to this naming convention. The letters assigned to each rail line generally conform to the order in which each line went into operation.

The current planned designations follow:

Prior Designation	Updated Designation	Updated Line Badge
Blue Line	A Line	
Red Line	B Line	
Green Line	C Line	
Purple Line	D Line	
Expo Line	E Line	
Orange Line	G Line	
Silver Line	J Line	
Gold Line	L Line	

The Gold Line has been assigned the letter L for clarity and consistency systemwide while service plans are being developed for the Regional Connector Project. When the Regional Connector is completed, the appropriate sections of the Gold Line will become the A Line or the E Line.

APPENDIX B: Los Angeles County Local Fixed and Demand Response Route Transit Operators

Operator	Municipal	Local Return
Agoura Hills		X
Alhambra		X
AVTA	X	X
Artesia		X
Avalon		X
Azusa		X
Baldwin Park		X
Beach Cities	X	X
Bell		X
Bell Gardens		X
Bellflower		X
Beverly Hills		X
Burbank		X
Calabasas		X
Carson		X
Cerritos		X
Commerce	X	X
Compton		X
Covina		X
Cudahy		X
Culver City	X	X
Downey		X
Duarte		X
El Monte		X
El Segundo		X
Foothill	X	X
Gardena	X	X
Glendale		X
Glendora		X
Hawthorne		X
Huntington Park		X
Inglewood		X

Operator	Municipal	Local Return
La Puente		X
Lawndale		X
Long Beach	X	X
Los Angeles	X	X
Los Angeles County		X
Lynwood		X
Manhattan Beach		X
Malibu		X
Maywood		X
Monrovia		X
Montebello	X	X
Monterey Park		X
Norwalk	X	X
Palos Verdes Estates		X
Paramount		X
Pasadena		X
Pico Rivera		X
Pomona		X
Redondo Beach		X
Rosemead		X
San Fernando		X
SCVTA	X	X
Santa Fe Springs		X
Santa Monica	X	X
Sierra Madre		X
South Gate		X
Torrance	X	X
West Covina		X
West Hollywood		X
Westlake Village		X
Whittier		X
Total	12	62

Many of the Local Return systems listed above do not provide fixed route service but instead provide Demand Response services: Hawthorne, Malibu, and Manhattan Beach are examples.



NEXTGEN Bus Plan



Metro

January 23, 2020
Regular Board Meeting

Building a World-Class Bus System

RIDERSHIP

- 5 %

+ 5 %

+ 15-20 %

+ 25-30 %

RESOURCES

- 10 %

0 %

+ 10 %

+ 20 %

Reduce operating resources

Schedule to current demand

Reduce duplication

Discontinue unproductive segments

No reallocation of resources

WHERE WE ARE >

Reconnect with our customers

Create service tiers based on projected demand

Connect the dots

Coordinate with Muni

Simplify routes and schedules

Reallocate duplicative & unproductive service

Create a Transit First LA County

Invest in speed and reliability infrastructure

Create safe & comfortable waiting environments

Establish facilities to optimize layovers

Reinvest resources to improve lifeline services

Secure Future Funding

Full buildout of consistent frequencies by service tiers

Create all lines all day all week

Comparing the Alternatives

**Existing
Conditions
Today**

**Scenario A
Reconnect**

**Scenario B
Transit First**

**Scenario C
Future Funding**

Resources (Rev. Hrs)

7.0m

7.0m

7.0m

9.4m

Resources (Rev. Mi)

75.0m

75.0m

80.5m

105.0m

High-Frequency Lines (weekday)
Every 10 min or better

16

28

29

46

High-Frequency Lines (weekend)
Every 10 min or better

2

14

14

19

People w/walk access to high-frequency service
(weekday)

900,000

2.15m

2.17m

2.96m

People w/walk access to high-frequency service
(weekend)

630,000

1.14m

1.18m

1.49m

Ridership Increase

0

+5-10%

+15-20%

+25-30%

% riders who lose convenient walk access to transit

0

0.3%

0.3%

0.3%

Translating Lessons Learned Into Service Concepts

- **84% of LA County residents have used transit at least once in the past year**
Minimize discontinued segments
- **Fast/Frequent/Reliable service is key**
Create a competitive transit network
- **Metro's current system is not always competitive to get people where they want to go**
Build a network that reflects travel today & tomorrow
- **The greatest opportunity to grow ridership is between midday & evening when many trips are short distance**
Improve service for midday, evening & weekend
- **Need to integrate Metro's Equity Framework into the planning process**
Provide better service in equity-focused areas

The Metro Customer Experience



1 Speed & Reliability

Walk up & ride

Fast, reliable,
& predictable

Consistent & simple
routing



2 Stop Access & Waiting

Easy to find & access

Comfortable, convenient,
& well-informed

Safe and Secure



3 Boarding & Riding

Fast all-door boarding

Smooth, quiet ride

On-board information

NextGen Frequent Lines



Service Design Warrants

NextGen

Rapid

Frequent Headways	5-10 min	5-10 min
Stop Spacing	0.25-0.3 mi	0.5-0.75 mi
Transit Priorities/bus lanes	✓	✓
Bus Bulbs/Islands	✓	✗
Stop Amenities	✓	✓
Faster Boarding	✓	✗
Branded Buses and Stations	✗	✓
Headway Operations/Line Managers	✓	✓

Phasing Improvements

Capital investments create opportunities for system enhancements.

- Revenue Miles
- Capital Programs
- Current Operations

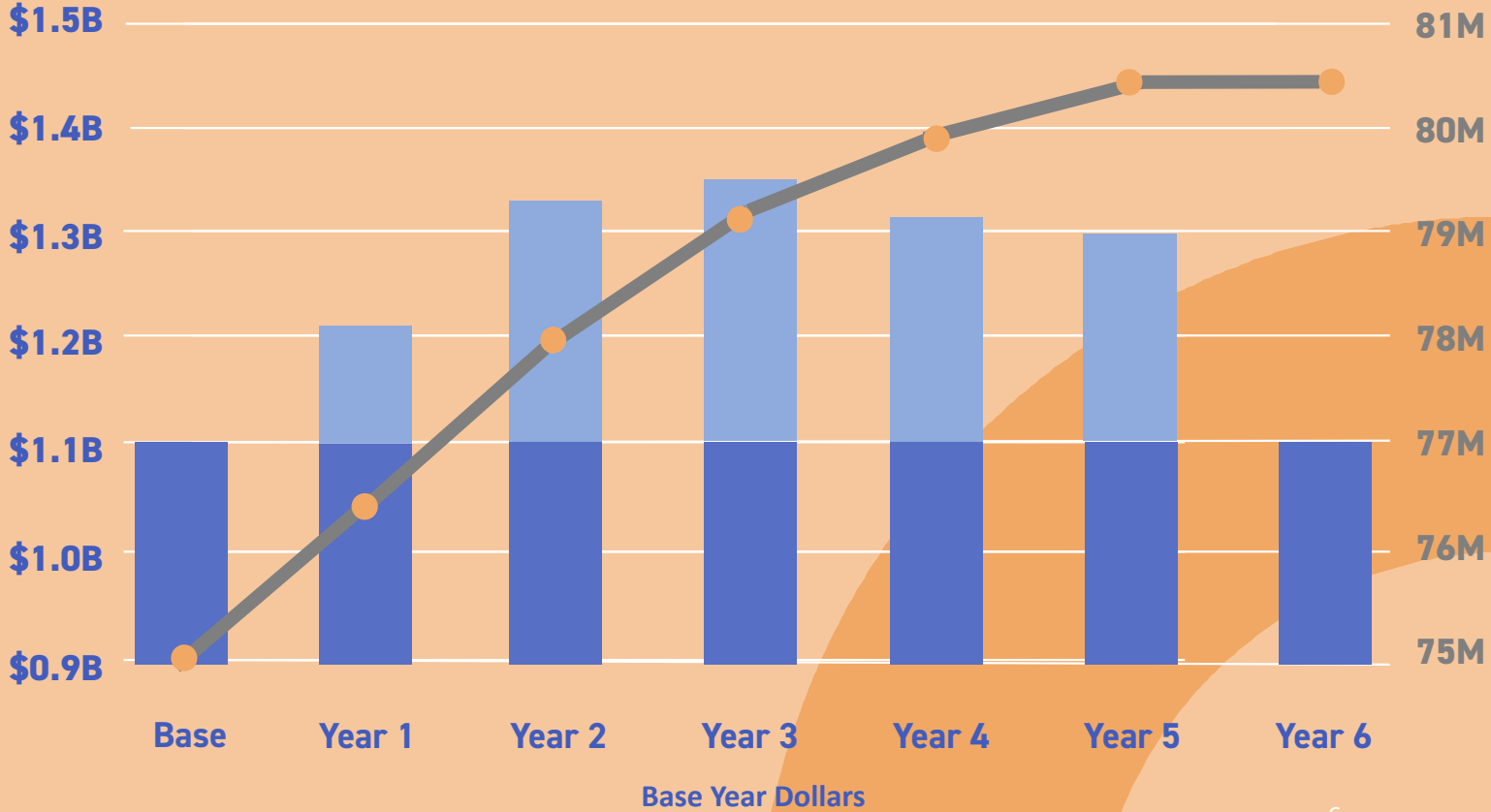

Transit First

The full network complements Muni lines, Metro Rail, & Metrolink services

83% of Metro's bus riders would have frequent service all-day (compared with 48% today)

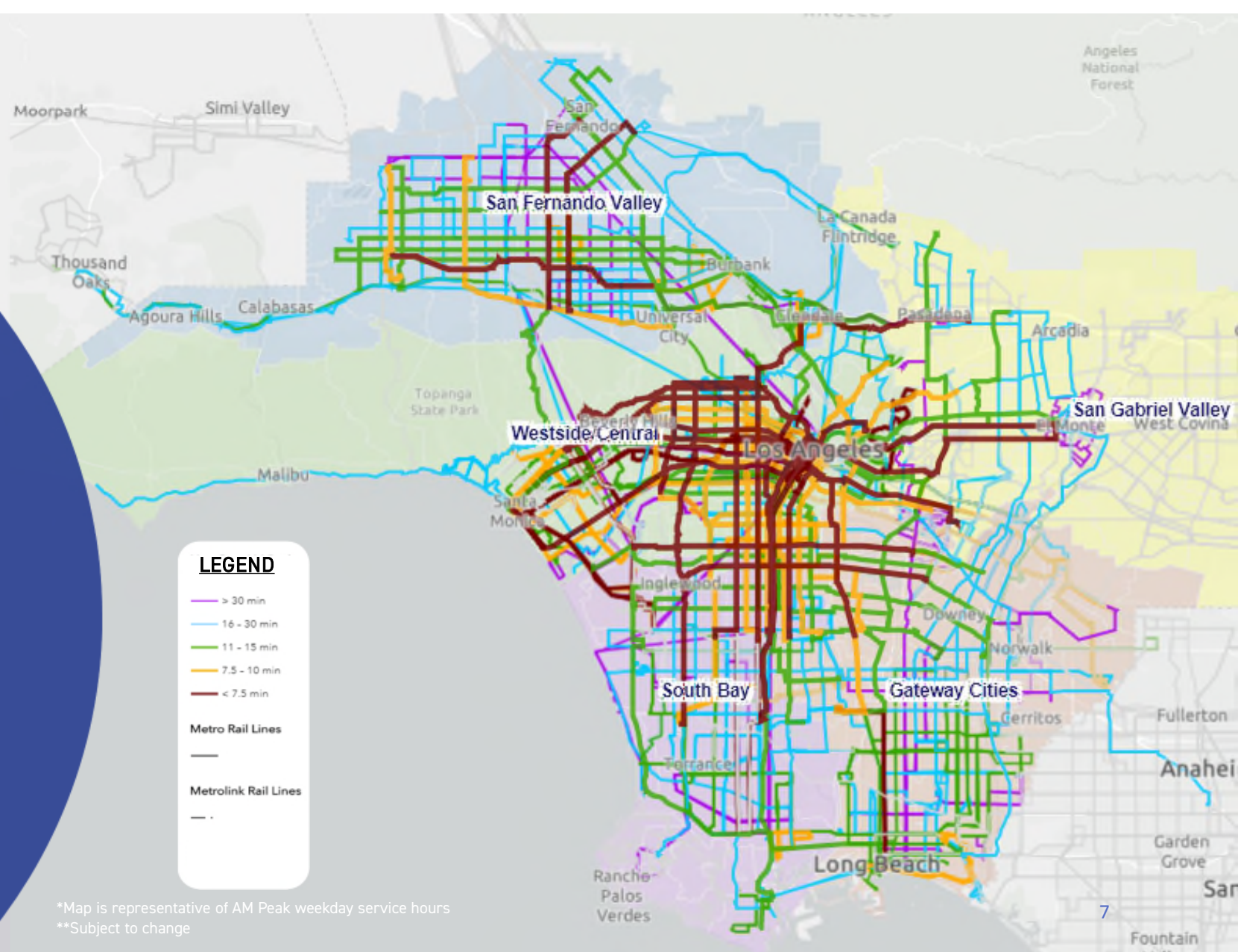

Next Steps



Historical Ridership Trends

		1985	1990	1997	2000	2005	2010	2015	2017	
1	Bus	LACMTA (Bus)	497,158,321	401,054,700	351,289,226	359,001,513	377,268,411	365,975,482	342,749,692	289,999,055
2		Muni Operators	54,900,600	65,573,000	87,838,916	105,579,793	135,992,801	137,095,260	127,749,026	99,059,684
3		Subtotal (Bus)	552,058,921	466,627,700	439,128,142	464,581,306	513,261,212	503,070,742	470,498,718	389,058,739
4		<i>Change</i>		-15%	-6%	6%	10%	-2%	-6%	-17%
5	Rail	LACMTA (Rail)			34,287,541	57,817,208	74,242,912	94,314,992	110,281,822	113,397,844
6		Metrolink			5,534,633	6,978,588	10,693,327	12,005,849	13,062,262	14,396,198
7		Subtotal (Rail)			39,822,174	64,795,796	84,936,239	106,320,841	123,344,084	127,794,042
8		<i>Ann Change</i>				63%	31%	25%	16%	4%
9	Access	Access Services					2,777,037	4,092,766	4,389,944	
10		<i>Ann Change</i>						47%	7%	
11	Total	Total (System)	552,058,921	466,627,700	478,950,316	529,377,102	598,197,451	612,168,620	597,935,568	521,242,725
12		<i>Ann Change</i>		-15%	3%	11%	13%	2%	-2%	-13%

Transit First

The full network complements Muni lines, Metro Rail, & Metrolink services

83% of Metro's bus riders would have frequent service all-day (compared with 48% today)

